



Hero

Splendor
PRO

While every care is taken in publishing this catalogue, the company will not be responsible for any error and omission.

This catalogue is the property of Hero MotoCorp Ltd.
Copy right of this catalogue is reserved.



INDEX

INSTRUCTIONS
(Use of Parts Catalogue)

1

BLOCK INDEX

2

ENGINE GROUP

3

FRAME GROUP

4

PART NO. INDEX

5

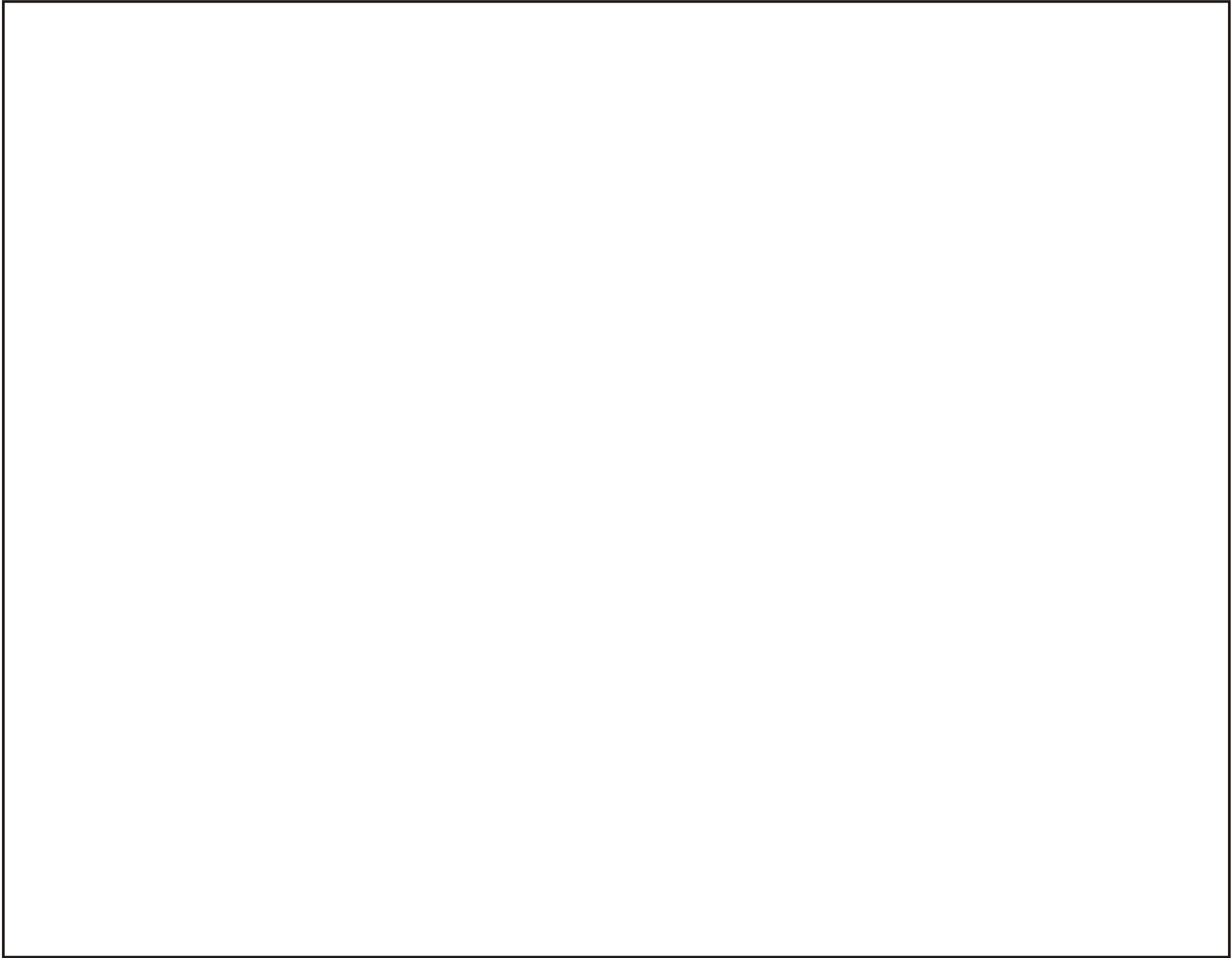

INSTRUCTION FOR USE OF PARTS CATALOGUE

This parts catalogue is compiled of all service parts and Flat Rate Time (F.R.T.) For **Hero MotoCorp** Splendor PRO Motorcycle.

I. How to order parts

1. Information required

Replacement parts orders must contain both the **part number** and the **stamped number(s)** as described below. This is because any changes and modifications of parts are registered at **Hero MotoCorp** with the pertinent parts and stamped numbers.

Numbers needed

- (a) Carburettor parts : Part number and Stamped carburettor identification number.
- (b) Engine parts : Part number and Stamped engine number.
- (c) Frame parts : Part number and Stamped frame number.

2. Revision

When modifications or additions to this Parts Catalogue are made, a news letters/revised edition will be issued at an appropriate time, with successively progressing revision numbers. We recommend obtaining such revisions in order to keep your Parts Catalogue up-to-date at all times. To check whether a Parts Catalogue revision has been issued, please contact SPARE PARTS DEPARTMENTS, **Hero MotoCorp LTD.**

II. How to read this Parts Catalogue

1. Make-up of the part number

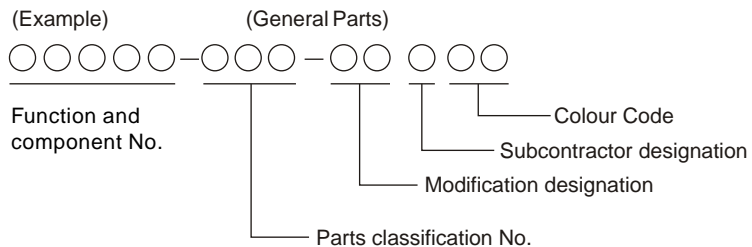

(Example) Bolts, nuts and other standard parts

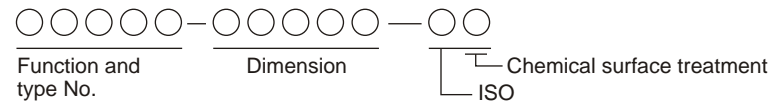

2. Colour codes

The colour code at the end of the part number indicates the colour. Code below ZA in alphabetical order (such as ZA, ZB, ZC, etc.) do not indicate the colour directly, but reference must be made to the **Hero MotoCorp** code given in the description column of this Parts Catalogue.

COLOUR DESCRIPTION MAIN BODY COLOUR	COLOUR CODE COLOUR REF.
BLACK	NH-1
BLACK	NH-1
CLOUD SILVER ME	NH-35M
CANDY BLAZING RED	R-195C
EXCELLENT BLUE ME	PB-365M
HI- GRANITE BLUE ME	PB-307M
PALACE MAROON ME	R-308M
HEAVY GRAY ME. ()	NH-194M-U

1

3. Abbreviations

The following abbreviations are used in this Parts Catalogue.

ASSY.Assembly	L (100L).....Link (100 Links)
COMP.Complete	A.C.Alternating current
R.Right	D.C.Direct current
L.Left	INInlet
STD.Standard	EXH.Exhaust
MM.Millimeter	FR.Front
G.Gram	RR.Rear
T (22T).Tooth (22Teeth)	Hex.Hexagonal
A.Ampere	A.M.Attaching Mark
V.Volt	T.M.Transcript Mark
W.Watt	C.D.I.Capacitive Discharge ignition
KPH.Kilometers per hour	INC.Including
L.E.D.Light emitting diode	

4. Dimensions

All dimensions are given in millimeters (mm) except in the case of steel balls, tyres and tyre tubes and wheel rims.

Parts	Example	Interpretation
Bolt (Screw)	6 x 12	6mm diameter, 12mm length
Pin	8 x 14	8mm diameter, 14mm length
O-Ring	9.5 x 1.6	9.5mm diameter, 1.6mm thickness
Oil Seal	14 x 24 x 5	14mm inside diameter, 24mm outside diameter, 5mm thickness
Tube	5 x 130	5mm inside diameter, 130mm length

5. Supercedence of parts

Part numbers given under the part name in the "Description" column indicate that the part number has been superceded by that part number. **Hero MotoCorp** may make such supercedence without notice.

6. Assemblies

Sections framed with broken lines in the exploded view drawings are available as complete assemblies. (Their individual parts can also be obtained.)

7. Required Quantity

The number given in the "Reqd. No." column indicates the quantity of parts used in the section described in that block.

Parts with quantities in () represent optional parts.

Part whose required number is "N", is a part whose required number can be selected at need.

8. Part modifications and applicable serial numbers

In case where a part has been modified, the serial number of the first vehicle (or frame, engine, carburettor) bearing the modification is listed in the "Serial No." Column.

9. Illustration

Illustration of parts given in parts catalogue diagrams are provided for convenience identifying parts and may differ from the actual configuration of parts.

10. Models, area codes and applicable serial numbers

Models, area codes and applicable serial Nos. given in this parts catalogue can be identified as follows.

Example

Model	Area code	Type	Applicable Engine serial No.	Applicable Frame serial No.	Applicable carburettor identification No.
SPLENDOR PRO	ID	India	XXXXELY ZYYYYY	MBLXXXX ASYZYYYY	70B A 4LCL

11. Location of stamped serial number

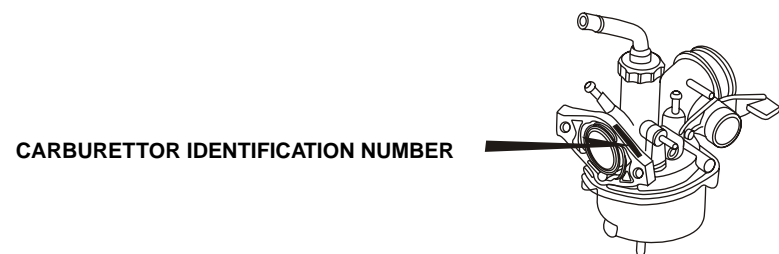
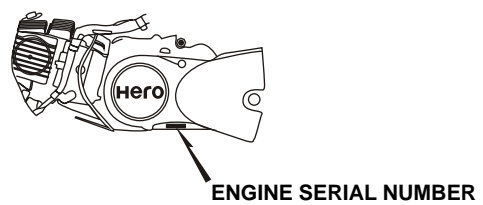
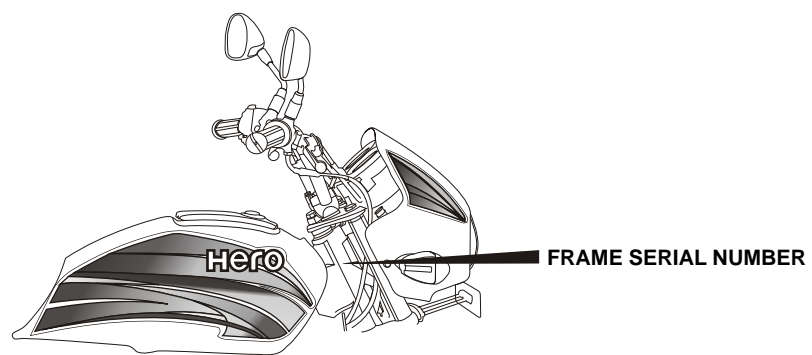

12. Selection table for lock or blank key

Refer to the following selection table to select the lock or blank key.

Type	Key No.	
TYPE 1	A**	B**
TYPE 2	C**	D**

Where ** is from 00-99

III. How to use the Flat Rate Time (F.R.T.)

This F.R.T. (Flat Rate Time) is used to determine the standard labour time allowed for replacement of parts covered by the warranty during the period the warranty is in effect. The F.R.T. for those parts which are not listed herein should be determined from the operation closely related to the replacement of that part.

1. The F.R.T. is based on the following service conditions.

- a. A liberal allowance is added to the net servicing time.
- b. Standard times specified are based on the condition that the necessary servicing tools listed in the service manual (motorcycle) which describes the HERO HONDA service policies are available close at hand and the work is performed by a mechanic with normal skill.
- c. Time required for inspection and operational test following the servicing is included in the F.R.T.

2. Method of computing

The job times are listed in tenth of an hour to simplify computation.

- (Example) 0.3 = 18 minutes
5.6 = 5 hours and 36 minutes

CONVERSION CHART			
Hours	Minutes	Hours	Minutes
0.1	6	0.6	36
0.2	12	0.7	42
0.3	18	0.8	48
0.4	24	0.9	54
0.5	30	1.0	60

3. Computing the F.R.T.

When several jobs are performed at the same time, make the calculation in the following manner.

a. Jobs of non duplicated nature

The F.R.T. for the job is obtained by totaling the F.R.T. for each part replaced. (Example) Replacement of cylinder and clutch spring.

SERVICE ITEM	F.R.T.
Cylinder	1.1
Clutch spring	0.7

The F.R.T. For the job is : $1.1+0.7=1.8$

b. Jobs of duplicated nature

Take the F.R.T. For the last part to be replaced.

(Example) Replacement of piston and cylinder head gasket.

SERVICE ITEM	F.R.T.
Cylinder head gasket	0.9
Piston	1.3

The F.R.T. for the job is : 1.3

c. Jobs of partially related nature

Total up the F.R.T. For all of the parts replaced and then subtract the F.R.T. for the duplicated operation.

(Example) Replacement of gearshift drum and crankshaft assembly.

SERVICE ITEM	F.R.T.
Gear Shift Drum	*3.3
Crank Shaft	*3.7
Crankcase Disassembly	*3.2

The F.R.T. for the job is : $(3.3+3.7)-3.2=3.8$

Crankcase disassembly is the duplicated operations.

The F.R.T. Shown with () includes engine removal and installation.

4. Operations other than replacing parts

a. Removed and installation

NO.	SERVICE ITEM	F.R.T.
1.	Engine	1.3
2.	Cylinder head	0.9
3.	Carburettor	0.3

b. Adjustment, measurement and cleaning

Engine

NO.	SERVICE ITEM	F.R.T.
1.	Ignition timing - inspection	0.2
2	Spark plug – adjustment and cleaning	0.1
3	Tappet adjustment	0.2
4	Carburettor idle – adjustment	0.1
5	Engine oil – inspection (excluding oil change)	0.1
6	Clutch – adjustment	0.1
7	Cleaner element – cleaning	0.2
8	Compression – pressure measurement	0.1
9	Battery – checking of electrolyte level and gravity	0.1
10	Carburettor – float level measurement	0.5
11	Oil filter cleaning	0.5
12	Throttle operation – adjustment	0.1

Frame

NO.	SERVICE ITEM	F.R.T.
1	Front brake – adjustment	0.1
2	Rear brake – adjustment	0.1
3	Brake – operation test	0.1
4	Headlight – aimings	0.1
5	Drive chain (includes tension adjustment however, does not include sprocket)	0.1

c. Overhaul

NO.	SERVICE ITEM	F.R.T.
1	Carburettor	0.5

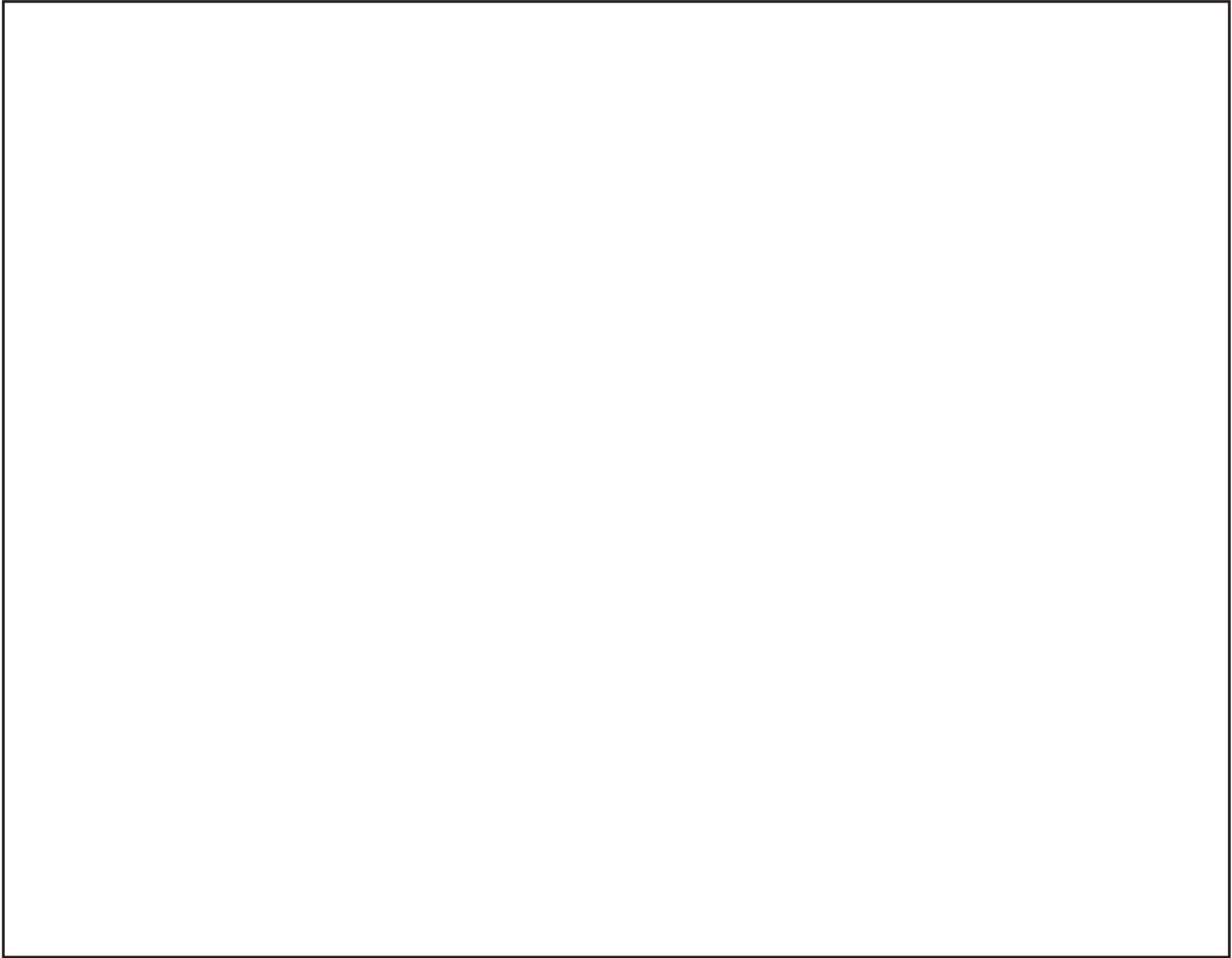

BLOCK INDEX – ENGINE GROUP

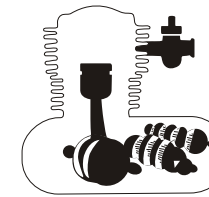
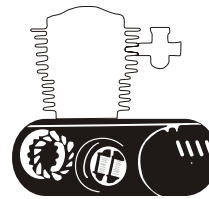
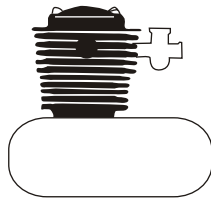

E-1	CYLINDER HEAD COVER/ INLET PIPE	19
E-2	CYLINDER/CYLINDER HEAD	20
E-3	CAM SHAFT/VALVE	21

E-4	CAM CHAIN TENSIONER	20
E-5	RIGHT CRANKCASE COVER	21
E-6	CLUTCH	22
E-7	LEFT CRANKCASE COVER/ A.C.GEN. ASSY.	24
E-7A	LEFT CRANKCASE COVER/ A.C.GEN. ASSY. (SELF START)	25
F-7B	STARTING CLUTCH	26
F-7C	STARTING MOTOR	27

E-8	CRANK CASE/OIL PUMP	26
E-9	CRANKSHAFT/PISTON	27
E-10	TRANSMISSION	28
E-11	KICK STARTER	29
E-12	GEARSHIFT	30
E-13	CARBURETTOR	32

2

BLOCK INDEX – FRAME GROUP

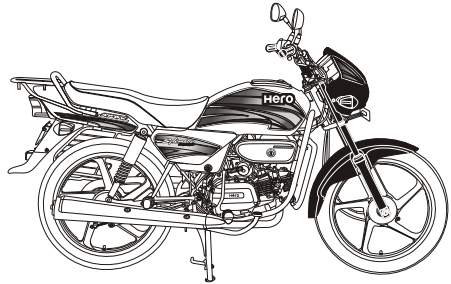

F-1V HEADLIGHT/FR. VISOR	43-44	
F-2V SPEEDOMETER/CABLE/KEY SET	45-46	
F-3 HANDLE LEVER/SWITCH/	CONTROL CABLE	47-48
F-4 HANDLE PIPE/TOP BRIDGE	49	
F-5 STEERING STEM/HORN	50	
F-6 FRONT FENDER.....	51	
F-7 FRONT FORK	52	

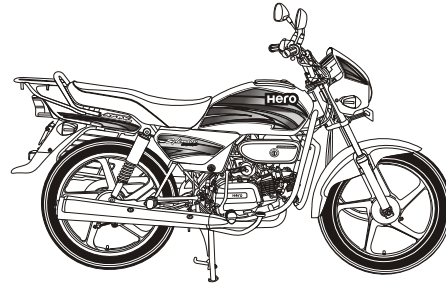

F-8 FRONT BRAKE PANEL.....	53
F-9 FRONT WHEEL	54
F-10 REAR BRAKE PANEL	55
F-11 REAR WHEEL	56

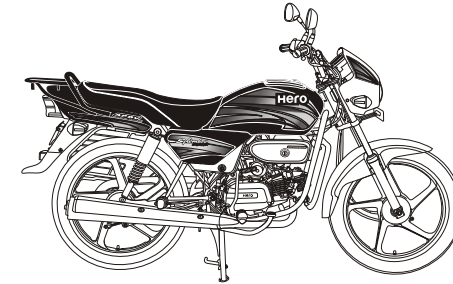

F-12 SEAT ASSY./ REAR COWL/	REAR CARRIER	46
F-13 FUEL TANK.....	47	
F-14 SIDE COVER	48	
F-15 AIR CLEANER	49	

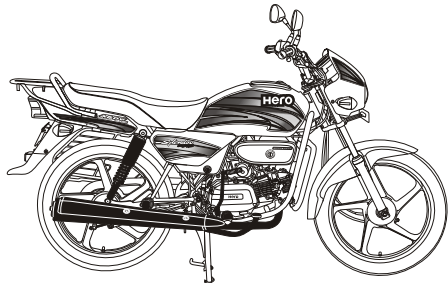

F-16 EXHAUST MUFFLER	50
F-17 STEP ASSY/ KICK STARTER.....	51
F-18 MAIN STAND/PEDAL BRAKE	
F-19 REAR FORK / CHAIN CASE	52
F-20 REAR CUSHION	53

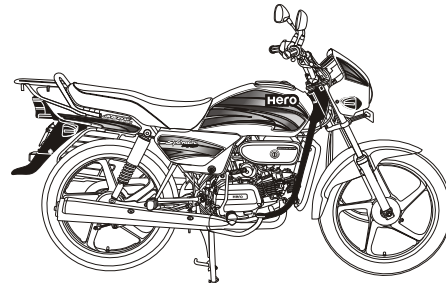

F-21 REAR FENDER	54
F-22 WINKERS	55
F-23 TAIL LIGHT	52
F-24 WIRE HARNESS/BATTERY	56
F-25 FRAME BODY/UTILITY BOX	57

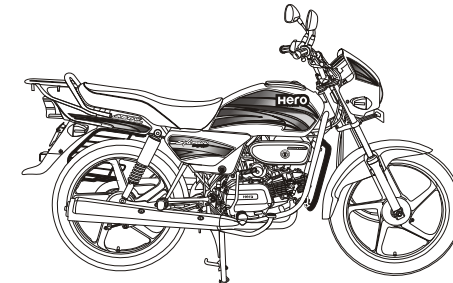

F-26 TOOL	58
F-27 STRIPES/MARKS.....	68
F-28 GUARD ENGINE	69
F-29 GUARD SARI	70
F-30 MARK/CAUTION.....	

BLOCK INDEX-ENGINE GROUP

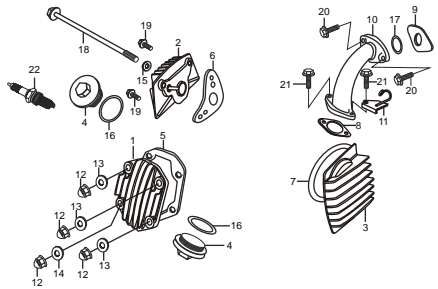
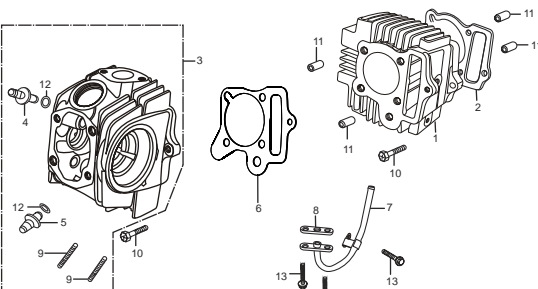
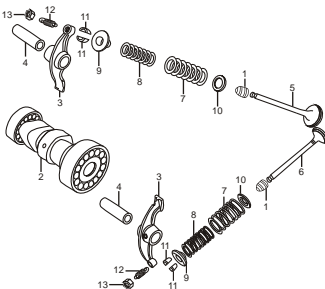
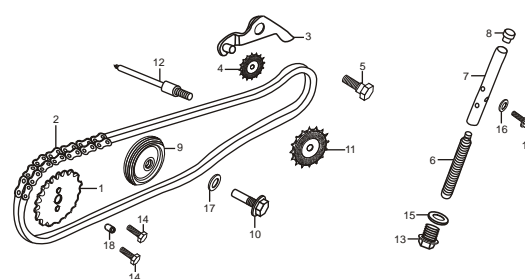
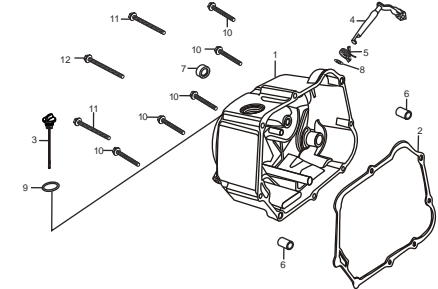
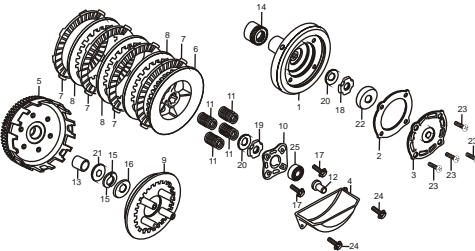
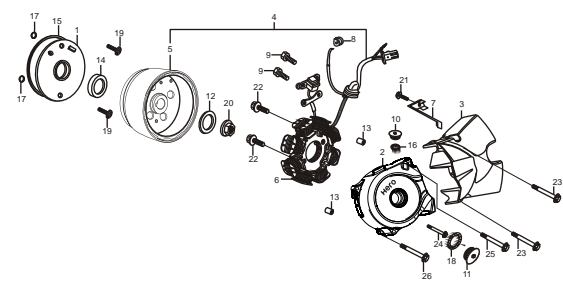
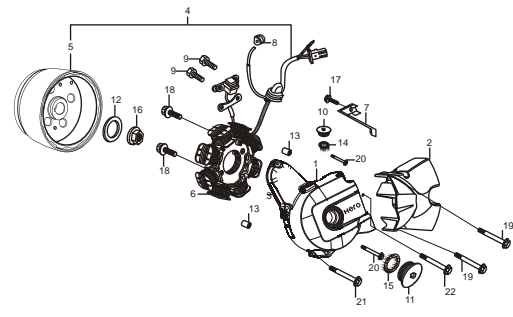
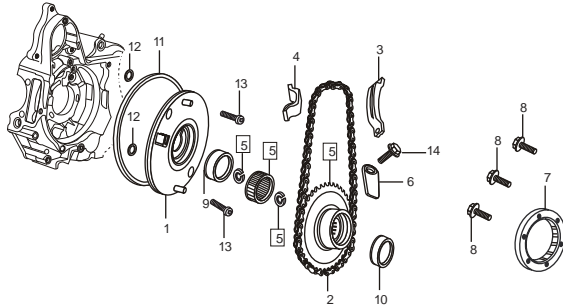
<p>E-1 19</p>	<p>E-2 20</p>	<p>E-3 21</p>
		
<p>E-4 22</p>	<p>E-5 24</p>	<p>E-6 26</p>
		
<p>E-7 22</p>	<p>E-7A 22</p>	<p>E-7B 22</p>
		

BLOCK INDEX-ENGINE GROUP

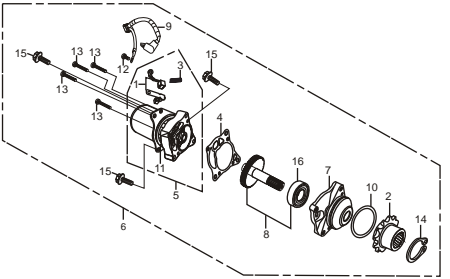
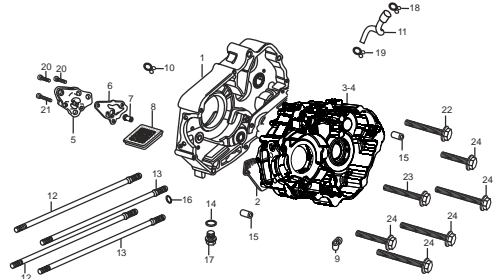
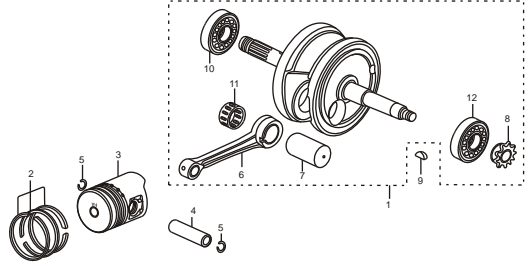
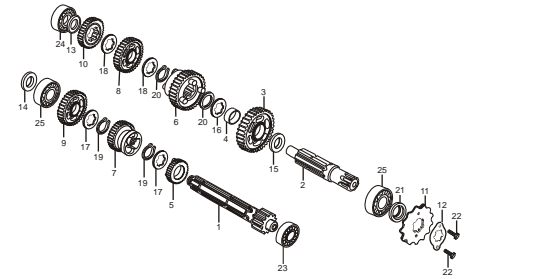
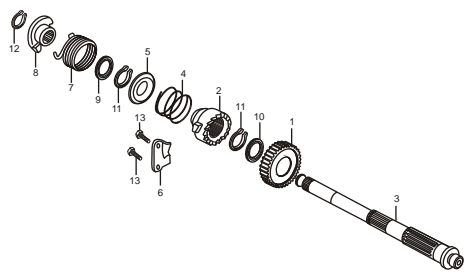
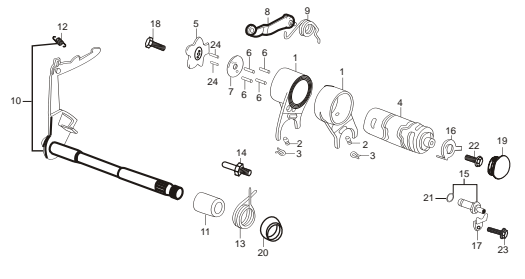
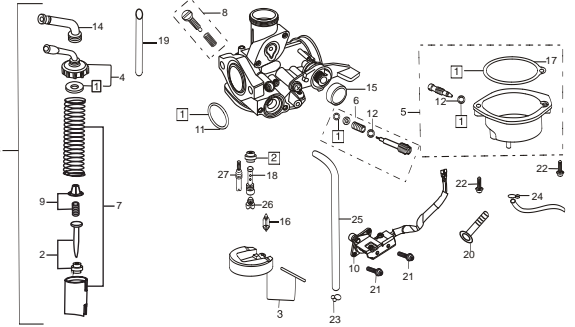
E-7C	19	E-8	20	E-9	21
					
E-10	22	E-11	24	E-12	26
					
E-13	22	E-7A	22	E-7B	22
					

BLOCK INDEX-FRAME GROUP

<p>F-1V 29</p>	<p>F-2V 31</p>	<p>F-3 33</p>
<p>F-4 35</p>	<p>F-9 36</p>	<p>F-11 37</p>
<p>F-12 39</p>	<p>F-13 42</p>	<p>F-14 44</p>

BLOCK INDEX-FRAME GROUP

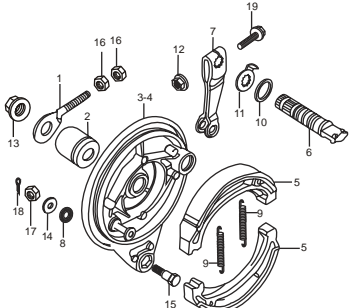
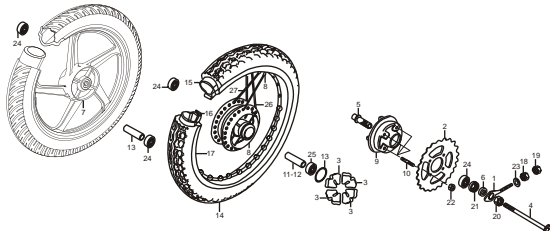
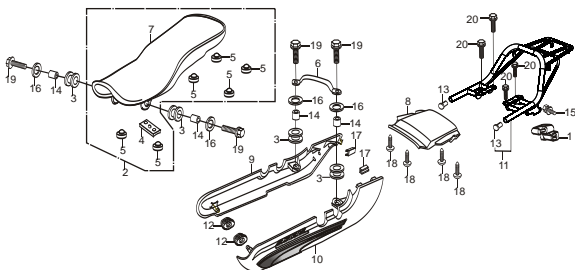
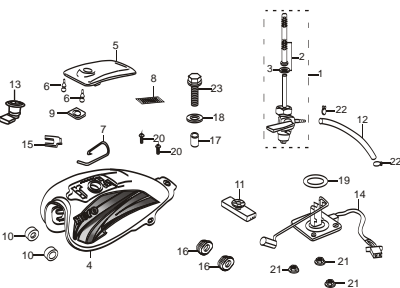
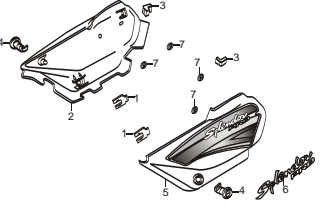
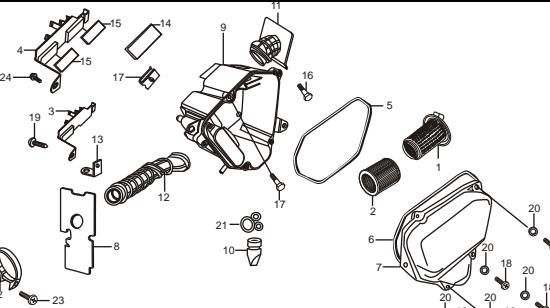
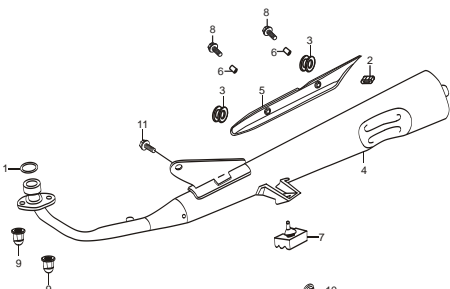
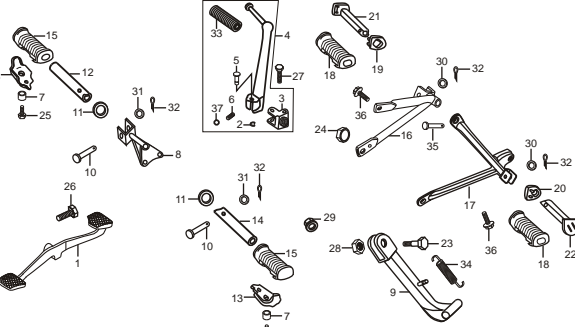
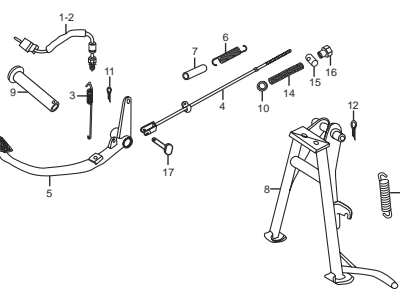
F-1V	29	F-2V	31				33
F-4	35	F-9	36				37
F-12	39	F-13	42				44

BLOCK INDEX-FRAME GROUP

F-16 46	F-24 47	F-26 49
F-27 50		

BLOCK INDEX-FRAME GROUP

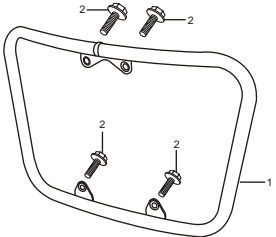
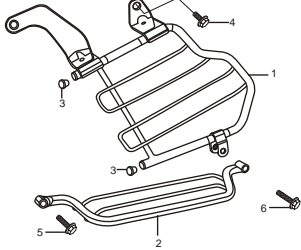
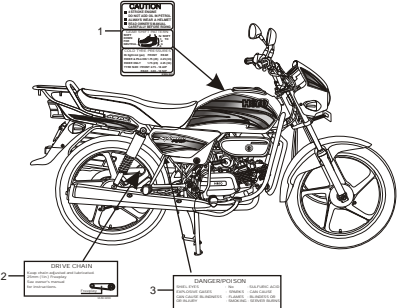
F-16	46	F-24	47	F-26	49
			<p>F-27</p> <p>50</p>		

ENGINE GROUP

E - 1 CYLINDER HEAD COVER/ INLET PIPE

FR.

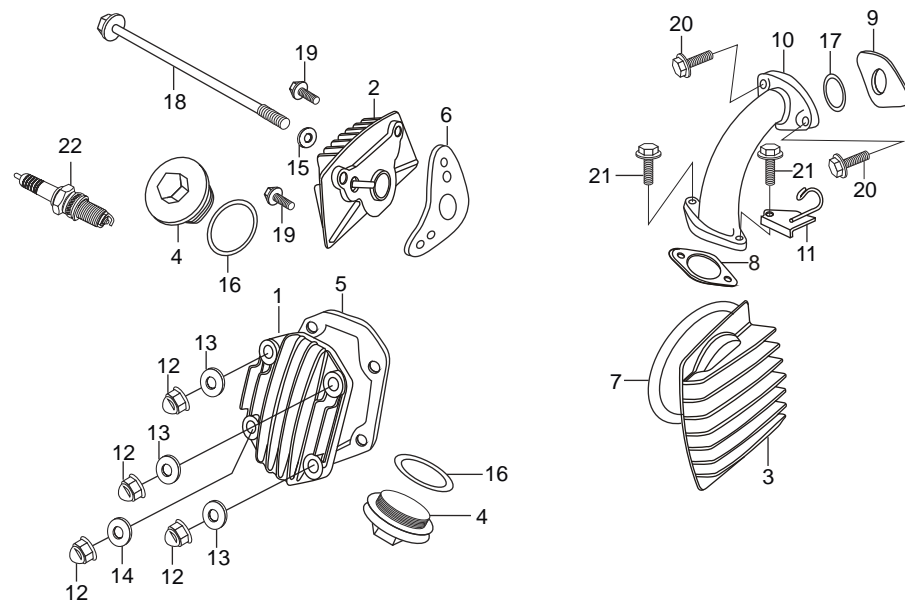

Service Item	F.R.T.	Ref. No.	Part No.	Description	Reqd. No. SPLENDOR PRO			
					DRUM			
					KICK		SELF	
					SPOKE	CAST	SPOKE	CAST
* COVER, CYLINDER HEAD	0.3	1	12301-KWH-960	COVER, CYLINDER HEAD	1	1	1	1
* GASKET, CYLINDER HEAD COVER ...		2	12331-KWH-960	COVER CYLINDER R. HEAD SIDE	1	1	1	1
* COVER, 'R' CYLINDER HEAD SIDE ...	0.1	3	12341-KWH-960	COVER CYLINDER L. HEAD SIDE	1	1	1	1
* COVER, 'L' CYLINDER HEAD SIDE	0.2	4	12361-035-000	CAP, TAPPET ADJUSTING HOLE	2	2	2	2
* SPARK PLUG	0.1	5	12391-GW8-681	GASKET, CYLINDER HEAD COVER.....	1	1	1	1
* INSULATOR, CARBURETTOR	0.2	6	12394-GW8-681	GASKET CYL. HEAD R. SIDE COVER.....	1	1	1	1
* PIPE, INLET.....	0.3	7	12395-GW8-681	GASKET CYL. HEAD L. SIDE COVER	1	1	1	1
		8	16201-KWB-920	GASKET CARBURETTOR INSULATOR.....	1	1	1	1
		9	16211-459-750	INSULATOR, CARBURETTOR	1	1	1	1
		10	17110-KCC-870	PIPE, COMP INLET.	1	1	1	1
		11	18655-KWA-940	STAY, AI TUBE.....	1	1	1	1
		12	90201-GF6-000R	NUT, CAP, 7MM	4	4	4	4
		13	90442-GF6-000	WASHER, SEALING 7 MM.....	3	3	3	3
		14	90443-GF6-000	WASHER 'A' SEALING, 7 MM	1	1	1	1
		15	90461-357-000	WASHER, SEALING, 12 MM.....	1	1	1	1
		16	91302-KEV-900	O-RING, 30.8 X 3	2	2	2	2
		17	91304-GB1-900	O-RING, 25X 2.4	1	1	1	1
		18	95701-06110-00	BOLT, FLANGE, 6 X 110.....	1	1	1	1
		19	96001-06020-00	BOLT, FLANE, SH. 6 X 20	2	2	2	2

3

E - 1 CYLINDER HEAD COVER/ INLET PIPE

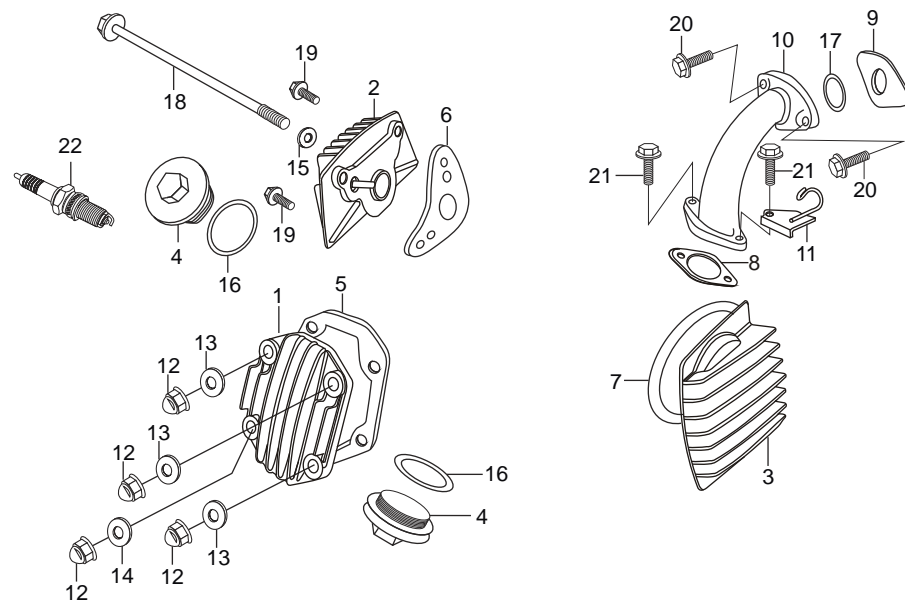

Service Item	F.R.T.	Ref. No.	Part No.	Description	Reqd. No. SPLENDOR PRO			
					DRUM			
					KICK		SELF	
					SPOKE	CAST	SPOKE	CAST
* COVER, CYLINDER HEAD.....	0.3	20	96001-06022-00	BOLT FLANGE, SH. 6 X 22.....	2	2	2	2
* GASKET, CYLINDER HEAD COVER ...		21	96001-06025-00	BOLT FLANGE, SH. 6X25.....	2	2	2	2
* COVER, 'R' CYLINDER HEAD SIDE ...	0.1	22	98056-57718-00	SPARK, PLUG.....	1	1	1	1
* COVER, 'L' CYLINDER HEAD SIDE	0.2							
* SPARK PLUG	0.1							
* INSULATOR, CARBURETTOR	0.2							
* PIPE, INLET.....	0.3							

E - 2 CYLINDER/CYLINDER HEAD

FR.

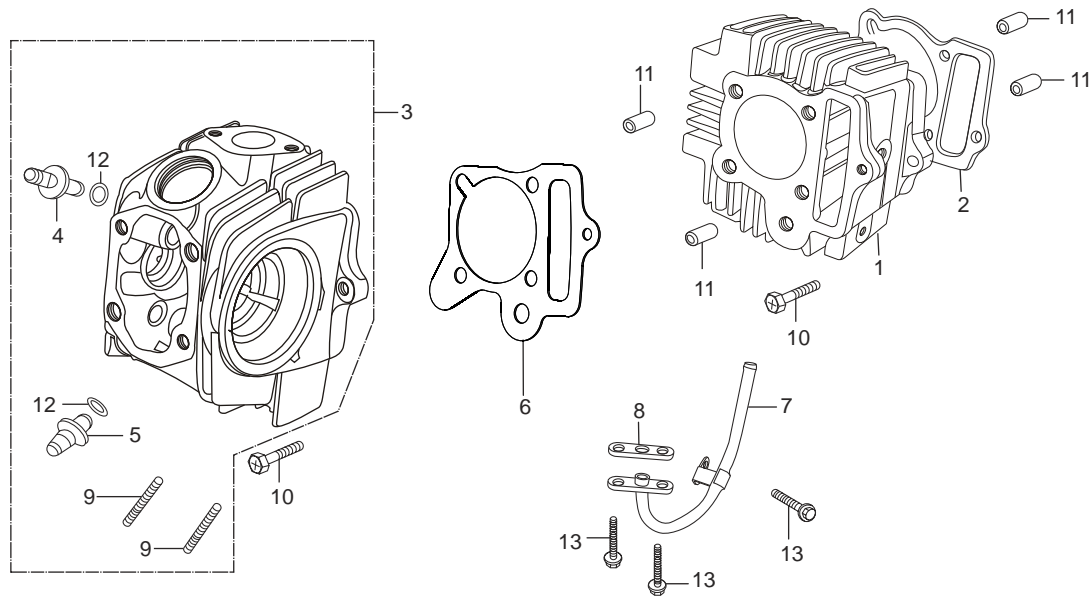

Service Item	F.R.T.	Ref. No.	Part No.	Description	Reqd. No. SPLENDOR PRO			
					DRUM			
					KICK		SELF	
					SPOKE	CAST	SPOKE	CAST
* CYLINDER	1.2	1	12101-AAD-H00	CYLINDER	1	1	1	1
* GASKET, CYLINDER	1.1	2	12191-GS4-762	GASKET, CYLINDER	1	1	1	1
* HEAD, COMP, CYLINDER	1.6	3	12200-KWH-960	HEAD COMP., CYLINDER.....	1	1	1	1
(INC. REAMING)		4	12237-GB4-305	GUIDE, INLET VALVE (O/S)	1	1	1	1
* GUIDE, VALVE		5	12245-GB4-305	GUIDE, EXH. VALVE (O/S).....	1	1	1	1
(ADD 0.3 FOR EACH)								
(EXC. VALVE REFACING)		6	12251-GF6-000	GASKET, CYLINDER HEAD.....	1	1	1	1
(ADD MORE 0.2 IF PERFORMED).....		7	18640-KCC-940	PIPE COMP. AIR FEED	1	1	1	1
* GASKET, CYLINDER HEAD	0.9	8	18645-MT4-730	GASKET AIR FEED PIPE	1	1	1	1
* BOLT, STUD, 6 X 32	0.3	9	90033-041-020	BOLT, STUD, 6 X 32	2	2	2	2
(ADD 0.1 FOR EACH)		10	90081-GFP-900	BOLT, SOCKET FLANGE 6X23.....	2	2	2	2
		11	90701-GF6-000	PIN, DOWEL, 8 X 14.....	4	4	4	4
		12	91305-028-150	O-RING, 9 X 1.6.....	2	2	2	2
		13	96001-06016-00	BOLT FLANGE SH. 6 X16	3	3	3	3

E -3 CAM SHAFT/VALVE

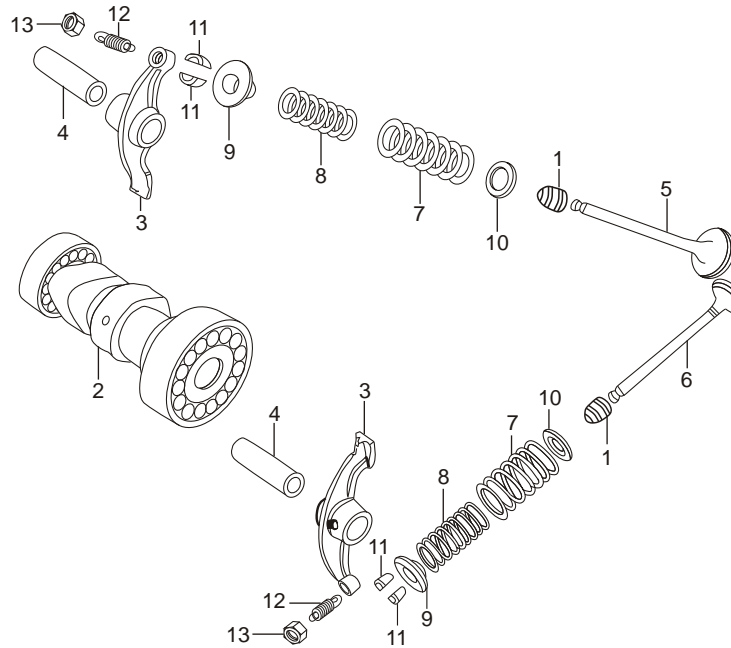

Service Item	F.R.T.	Ref. No.	Part No.	Description	Reqd. No. SPLENDOR PRO			
					DRUM			
					KICK		SELF	
					SPOKE	CAST	SPOKE	CAST
* CAMSHAFT COMP.0.7		1	12209-GB4-680	SEAL, VALVE STEM	2	2	2	2
* ARM, VALVE ROCKER1.1 (ONE OR ALL).....		2	14100-AAH-H41	CAM SHAFT COMP.	1	1	1	1
* VALVE1.4 (ADD 0.2 FOR EACH) (INC. REFACING)..... (EXC. VALVE GUIDE REPLACEMENT)		3	14430-KST-940	ARM, COMP, VALVE ROCKER	2	2	2	2
		4	14451-KST-940	SHAFT, ROCKER ARM.....	2	2	2	2
		5	14711-GN5-910	VALVE, INLET	1	1	1	1
		6	14721-GF6-010	VALVE, EXHAUST	1	1	1	1
* SPRING, VALVE INNER1.2 (ADD 0.1 FOR EACH) (INC. RELATIVE PART).....		7	14751-GBG-900	SPRING, VALVE OUTER.....	2	2	2	2
		8	14761-GBG-900	SPRING, VALVE INNER	2	2	2	2
		9	14771-GB4-680	RETAINER, VALVE SPRING	2	2	2	2
		10	14775-MA6-000	SEAT, VALVE SPRING OUTER	2	2	2	2
		11	14781-MA6-000	COTTER, VALVE	4	4	4	4
		12	90012-333-000	SCREW, TAPPET ADJUSTING	2	2	2	2
		13	90206-001-000	NUT, TAPPET ADJUSTING	2	2	2	2

E - 4 CAM CHAIN TENSIONER

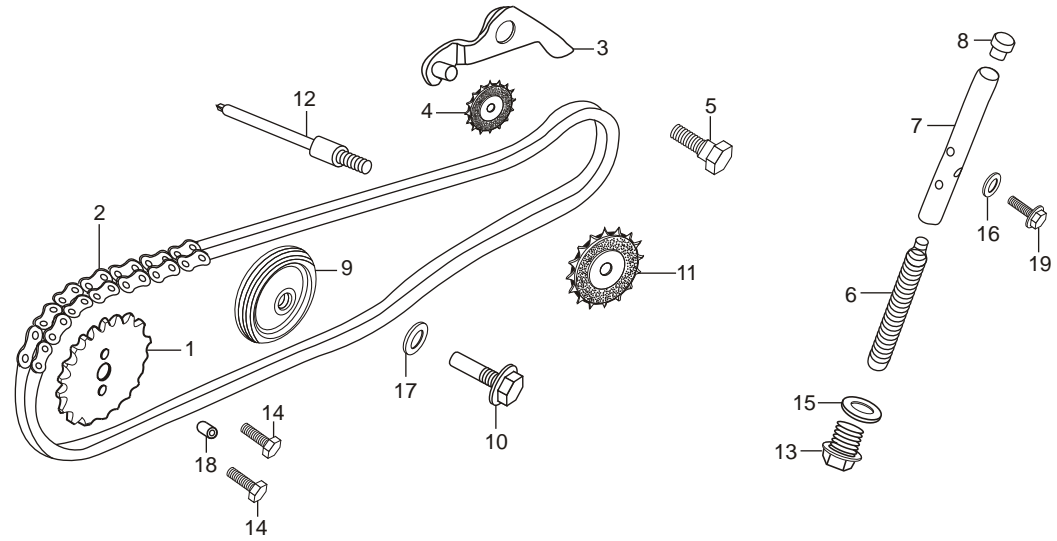

Service Item	F.R.T.	Ref. No.	Part No.	Description	Reqd. No. SPLENDOR PRO			
					DRUM			
					KICK		SELF	
					SPOKE	CAST	SPOKE	CAST
*SPROCKET, CAM(28T).....	0.4	1	14321-GB6-900	SPROCKET, CAM (28T).....	1	1	1	1
*ARM COMP., CAM CHAIN TENSIONER		2	14401-178-000	CHAIN, CAM.....	1	1	1	1
*ROLLER, CAM CHAIN TENSIONER		3	14500-035-020	ARM COMP., CAM CHAIN TENSIONER	1	1	1	1
*CHAIN, CAM	1.4	4	14502-086-000	ROLLER, CAM CHAIN TENSIONER	1	1	1	1
*PUSH ROD COM., TENSIONER	0.3	5	14531-035-000	PIVOT, CAM CHAIN TENSIONER	1	1	1	1
*ROLLER COMP., CAM CHAIN GUIDE .	1.0	6	14541-GB4-681	SPRING, CAM CHAIN TENSIONER.....	1	1	1	1
*SPROCKET, CAM CHAIN GUIDE	1.6	7	14550-GB0-910	PUSH ROD, COMP., TENSIONER	1	1	1	1
*SPINDLE, CAM CHAIN GUIDE		8	14566-086-030	HEAD, TENSIONER, PUSH ROD.....	1	1	1	1
		9	14610-086-000R	ROLLER COMP., CAM CHAIN GUIDE	1	1	1	1
		10	14615-035-010	PIN, GUIDE ROLLER.....	1	1	1	1
		11	14670-035-030L	SPROCKET, CAM CHAIN GUIDE.....	1	1	1	1
		12	14675-178-000	SPINDLE, CAM CHAIN GUIDE SPROCKET	1	1	1	1
		13	90081-035-000	BOLT, SEALING, 14MM	1	1	1	1
		14	90083-KVH-900	BOLT, KNOCK, 5MM	2	2	2	2
		15	90441-035-000	WASHER, SEALING, 14 MM	1	1	1	1
		16	90461-357-000	WASHER, SEALING, 12 MM	1	1	1	1
		17	90481-035-000	WASHER, 8MM	1	1	1	1
		18	90702-GB6-910	PIN, DOWEL, 8X12	1	1	1	1
		19	96001-06018-00	BOLT, FLANGE, SH. 6X18	1	1	1	1

E - 5 RIGHT CRANKCASE COVER

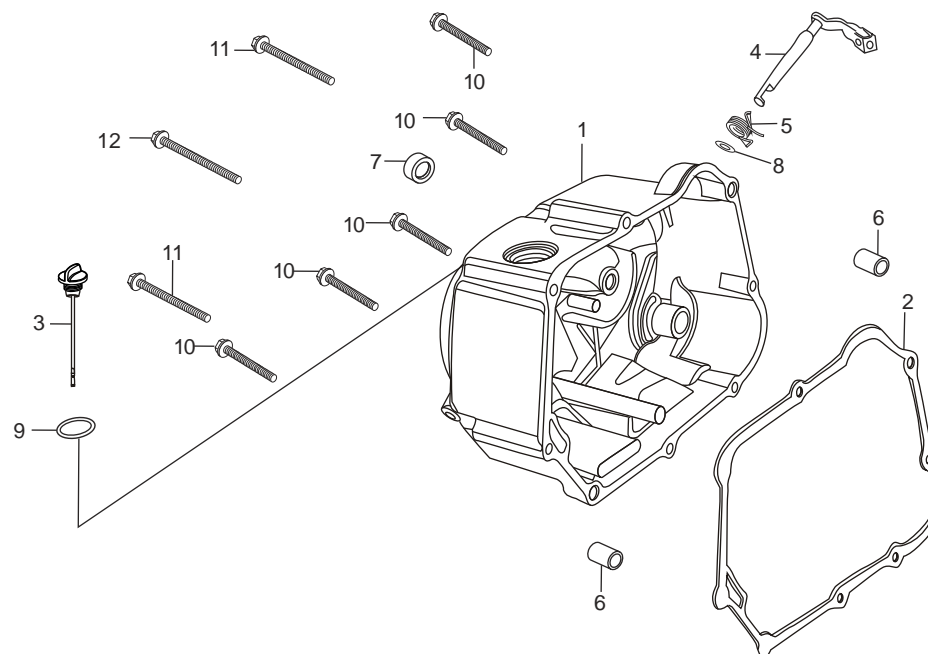

Service Item	F.R.T.	Ref. No.	Part No.	Description	Reqd. No. SPLENDOR PRO			
					DRUM			
					KICK		SELF	
					SPOKE	CAST	SPOKE	CAST
* COVER COMP, ÔRÕ CRANCK CASE . 0.8		1	11330-AAD-H00	COVER COMP., 'R' CRANK CASE	1	1	1	1
* GASKET, ÔRÕ CRANK CASE COVER . 0.6		2	11394-KW8-681	GASKET, 'R' CRANK CASE COVER	1	1	1	1
* LEVER COMP, CLUTCH 0.7		3	15650-AAC-H00	GAUGE, OIL LEVEL	1	1	1	1
(INC. RELATIVE PART).....		4	22810-198-000	LEVER COMP., CLUTCH	1	1	1	1
* OIL SEAL, 13.8 X 24 X 5		5	22815-166-000	SPRING, CLUTCH LEVER.....	1	1	1	1
		6	90702-GB6-910	PIN, DOWEL, 8 X 12	2	2	2	2
		7	91202-302-010	OIL SEAL, 13.8X24X5	1	1	1	1
		8	91303-719-000	O-RING, 9 MM	1	1	1	1
		9	91307-035-000	O-RING, 18X3.....	1	1	1	1
		10	96001-06040-00	BOLT, FLANGE, SH. 6 X 40	5	5	5	5
		11	96001-06065-00	BOLT, FLANGE, SH. 6 X 65	2	2	2	2
		12	96001-06080-00	BOLT, FLANGE, SH. 6 X 80	1	1	1	1

E - 6 CLUTCH

FR.

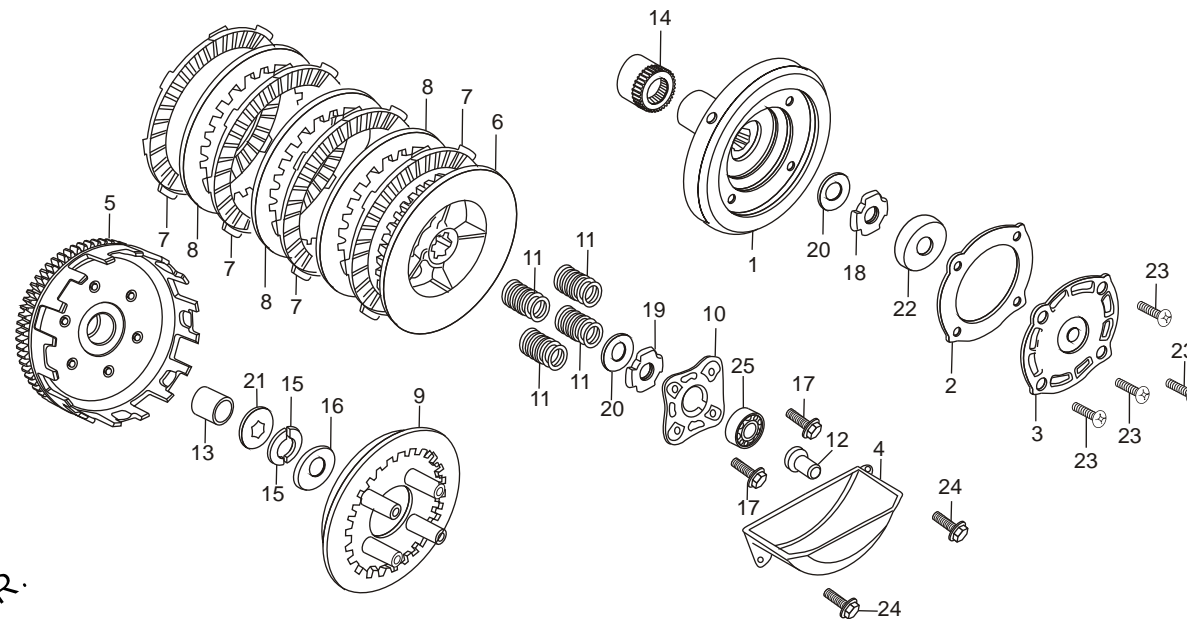

Service Item	F.R.T.	Ref. No.	Part No.	Description	Reqd. No. SPLENDOR PRO			
					DRUM			
					KICK		SELF	
					SPOKE	CAST	SPOKE	CAST
* ROTOR, OIL FILTER	0.9	1	15431-198-000	ROTOR, OIL FILTER	1	1	1	1
* COVER, OIL FILTER ROTOR	0.7	2	15439-198-691	GASKET, OIL FILTER ROTOR	1	1	1	1
* PLATE, OIL SEPARATOR	1.1	3	15441-198-000	COVER, OIL FILTER ROTOR	1	1	1	1
* OUTER COMP., CLUTCH	1.2	4	15661-198-000	PLATE, OIL SEPARATOR	1	1	1	1
* CENTER CLUTCH	1.2	5	22110-KST-940	OUTER COMP., CLUTCH	1	1	1	1
* DISC, CLUTCH FRICTION		6	22121-198-900	CENTER, CLUTCH	1	1	1	1
(ONE OR ALL)		7	22201-GF6-000	DISC CLUTCH FRICTION	4	4	4	4
(INC. RELATIVE PART)		8	22311-107-000	PLATE, CLUTCH	3	3	3	3
* PLATE, CLUTCH PRESSURE		9	22350-115-020	PLATE, CLUTCH PRESSURE	1	1	1	1
* PLATE, CLUTCH LIFTER		10	22361-KST-940	PLATE, CLUTCH LIFTER	1	1	1	1
* SPRING CLUTCH (ONE OR ALL)		11	22401-GF6-000	SPRING, CLUTCH	4	4	4	4
		12	22847-KCC-900	ROD, CLUTCH LIFTER	1	1	1	1
		13	23112-198-010	COLLAR, DRIVEN GEAR	1	1	1	1
		14	23121-KST-901	GEAR, PRIMARY DRIVE 18T	1	1	1	1
		15	23216-GF6-000	COTTER, MAIN SHAFT	2	2	2	2
		16	23217-GF6-000L	SET RING, MAIN SHAFT COTTER	1	1	1	1
		17	90050-KFL-850	SPECIAL BOLT FLANGE 6X25	2	2	2	2
		18	90231-087-010	NUT, LOCK, 14 MM	1	1	1	1
		19	90231-198-000	NUT 'B', LOCK, 14MM	1	1	1	1
		20	90432-086-000	WASHER LOCK 'B'	2	2	2	2

E - 6 CLUTCH

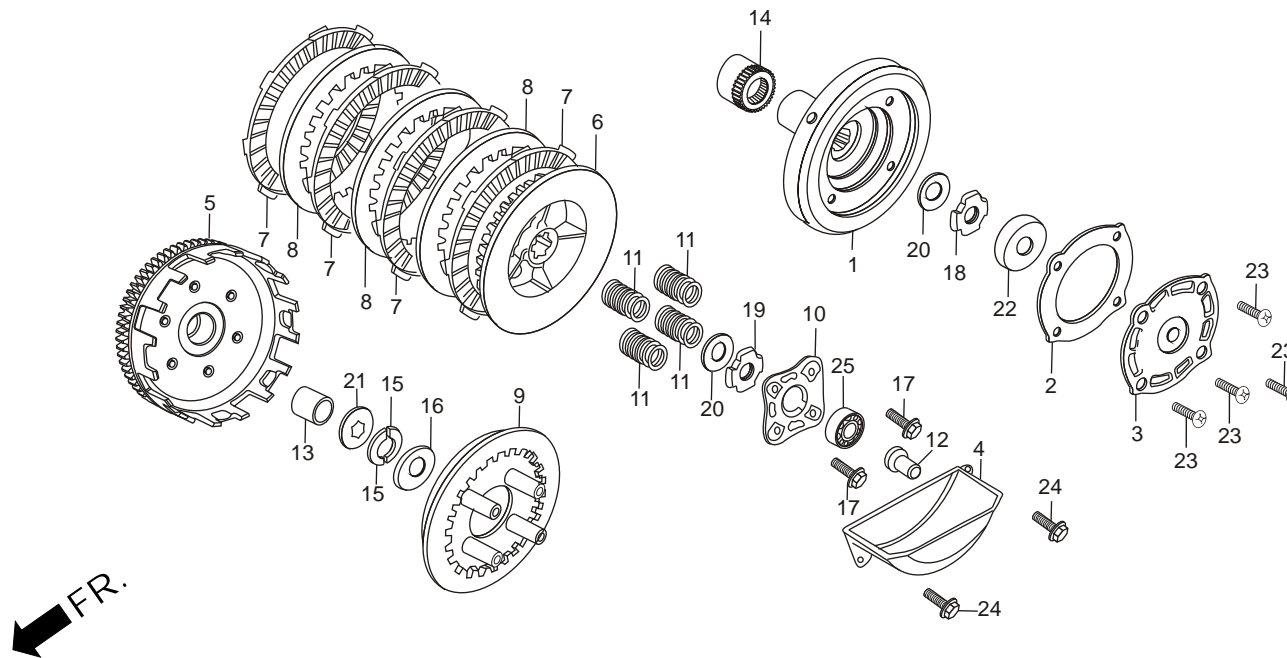

Service Item	F.R.T.	Ref. No.	Part No.	Description	Reqd. No. SPLENDOR PRO			
					DRUM			
					KICK		SELF	
					SPOKE	CAST	SPOKE	CAST
* ROTOR, OIL FILTER	0.9	21	90461-GF6-000	WASHER, SPLINE, 17 MM	1	1	1	1
* COVER, OIL FILTER ROTOR	0.7	22	91205-350-000	OIL SEAL, 6 X 25 X 6	1	1	1	1
* PLATE, OIL SEPARATOR	1.1	23	93600-05012-1H	SCREW, FLAT, 5 X 12	4	4	4	4
* OUTER COMP., CLUTCH	1.2	24	96001-06020-00	BOLT, FLANGE SH. 6 X 20	2	2	2	2
* CENTER CLUTCH	1.2	25	96100-60010-00	BEARING, RADIAL BALL, 6001	1	1	1	1
* DISC, CLUTCH FRICTION								
(ONE OR ALL)								
(INC. RELATIVE PART)								
* PLATE, CLUTCH PRESSURE								
* PLATE, CLUTCH LIFTER								
* SPRING CLUTCH (ONE OR ALL)								

E - 7
LEFT CRANKCASE COVER/
A.C. GEN. ASSY.

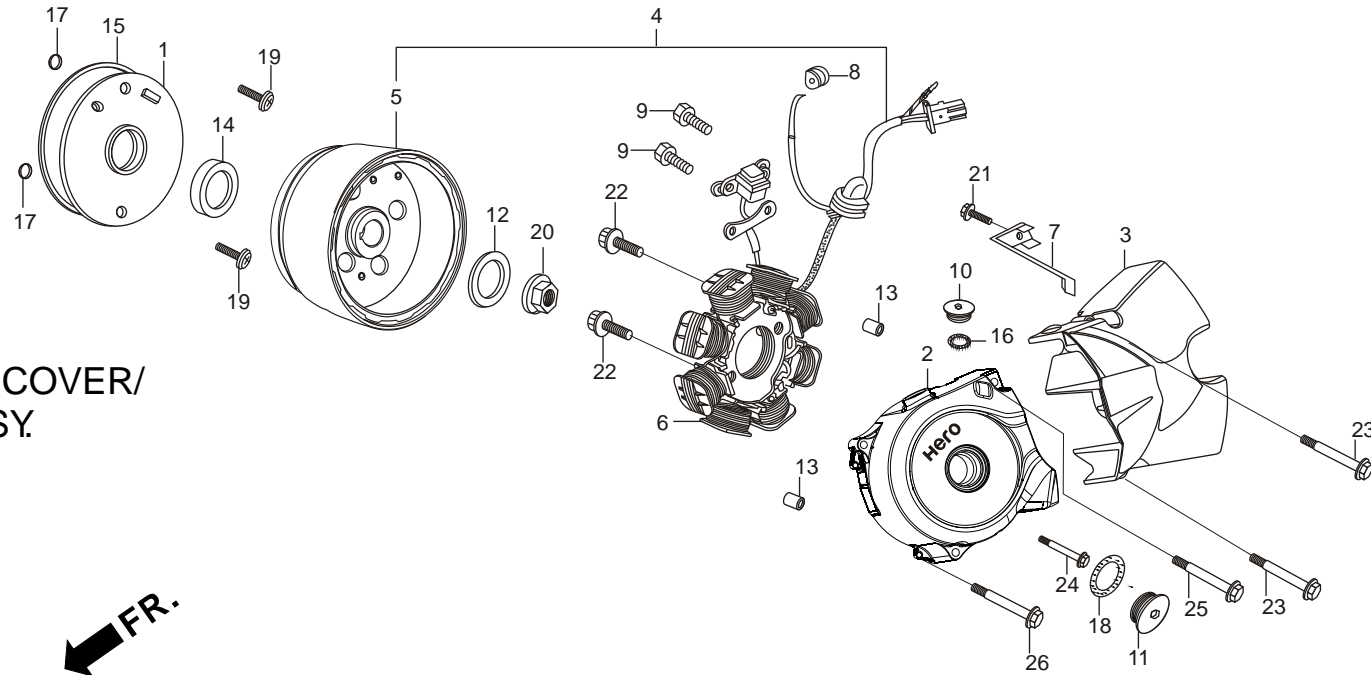

Service Item	F.R.T.	Ref. No.	Part No.	Description	Reqd. No. SPLENDOR PRO			
					DRUM			
					KICK		SELF	
					SPOKE	CAST	SPOKE	CAST
* COVER L. CRANKCASE	0.1	1	11321-KWA-940	PLATE OIL SEPARATOR.....	1	1	-	-
* A.C.GEN.ASSY,	0.5	2	11341-AAD-H00	COVER 'L' CRANK CASE	1	1	-	-
* STATOR, COMP,		3	11360-KWH-961	COVER RR L., CRANK CASE.....	1	1	1	1
* FLYWHEEL, COMP,	0.3	4	31100-KWH-971	A.C.GEN. ASSY.	1	1	-	-
* OIL SEAL, 18.9 X 30 X 5		5	31110-KWH-961	FLYWHEEL, COMP.....	1	1	-	-
* O-RING, 107 X 2		6	31120-KWH-961	STATOR, COMP.....	1	1	1	1
		7	32961-KST-940	CLAMPER ACG CORD.....	1	1	1	1
		8	32981-GB4-780	GROMMET NEUTRAL SWITCH CORD	1	1	1	1
		9	90083-KVH-900	BOLT KNOCK 5MM	2	2	1	1
		10	90084-KWH-960	CAP 14MM.....	1	1	1	1
		11	90087-KWH-960	CAP 30 MM.....	1	1	1	1
		12	90410-HC4-000	WASHER 10MM.....	1	1	1	1
		13	90702-GB6-910	PIN, DOWEL 8 X12.....	2	2	1	1
		14	91202-KTL-741	OIL SEAL 19X30X5.....	1	1	-	-
		15	91301-035-000	O-RING 107X2.....	1	1	-	-
		16	91303-377-000	O-RING 13.8X2.5.....	1	1	1	1
		17	91317-171-000	O-RING 6X1.7.....	2	2	-	-
		18	91356-KGH-901	O-RING 30 MM	1	1	1	1
		19	93600-06016-OA	SCREW, FLAT, 6 X16	2	2	-	-

E - 7
**LEFT CRANKCASE COVER/
 A.C. GEN. ASSY.**

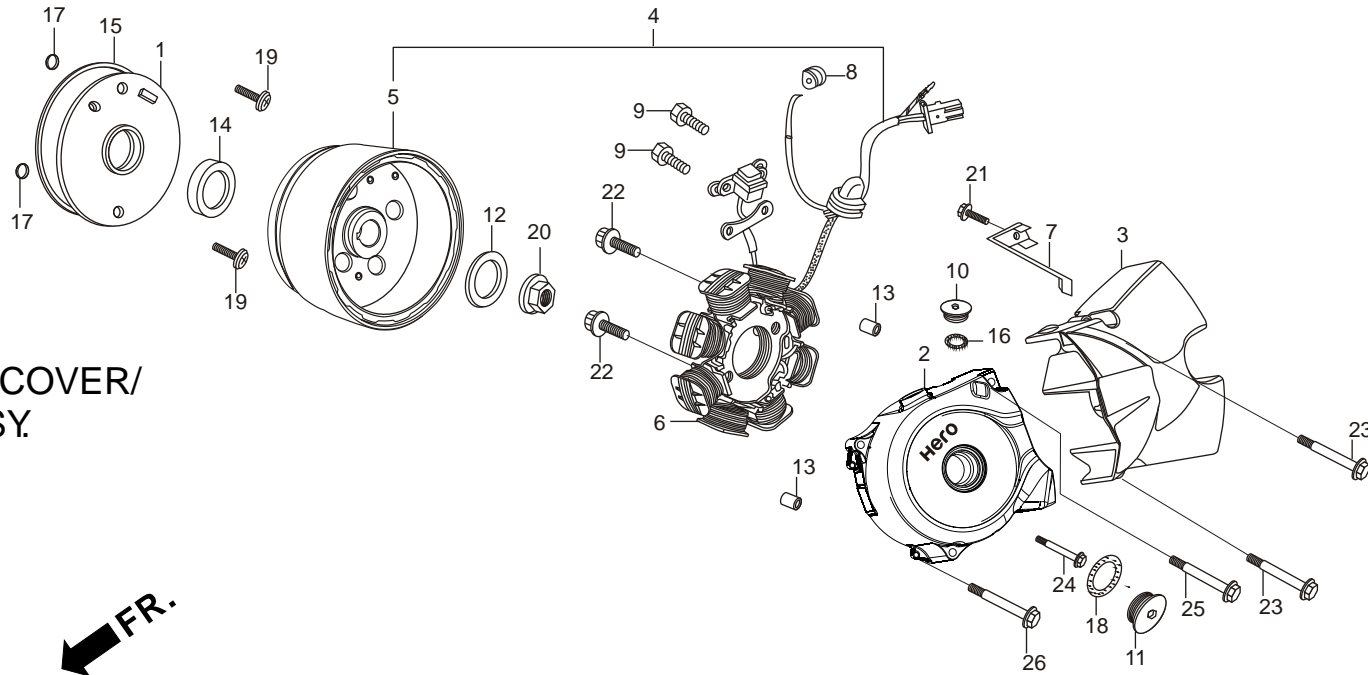

Service Item	F.R.T.	Ref. No.	Part No.	Description	Reqd. No. SPLENDOR PRO			
					DRUM			
					KICK		SELF	
					SPOKE	CAST	SPOKE	CAST
* COVER L. CRANKCASE	0.1	20	94050-10000	NUT FLANGE, 10 MM.....	1	1	-	-
* A.C.GEN.ASSY,	0.5	21	96001-06016-00	BOLT FLANGE, SH., 6X16	1	1	1	1
* STATOR, COMP,		22	96001-06020-00	BOLT FLANGE, SH. 6X20	2	2	1	1
* FLYWHEEL, COMP,	0.3	23	96001-06028-00	BOLT FLANGE, SH. 6X28	2	2	1	1
* OIL SEAL, 18.9 X 30 X 5		24	96001-06032-00	BOLT FLANGE, SH. 6X32	1	1	1	1
* O-RING, 107 X 2		25	96001-06060-00	BOLT FLANGE, SH. 6X60	1	1	-	-
		26	96001-06070-00	BOLT FLANGE SH. 6X70	1	1	1	1

E - 7 A
**LEFT CRANKCASE COVER/
 A.C. GEN. ASSY. (SELF START)**

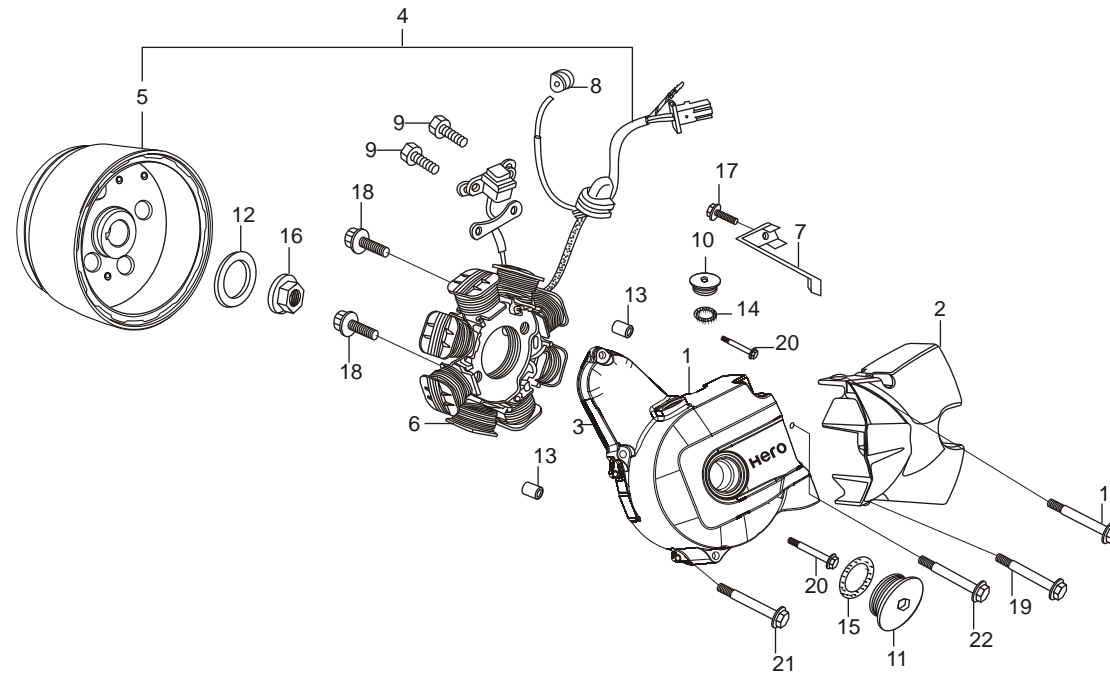

Service Item	F.R.T.	Ref. No.	Part No.	Description	Reqd. No. SPLENDOR PRO			
					DRUM			
					KICK		SELF	
					SPOKE	CAST	SPOKE	CAST
* COVER L. CRANKCASE	0.1	1	11341-AAD-H10	COVER 'L' CRANK CASE	-	-	1	1
* A.C.GEN.ASSY.	0.5	2	11360-KWH-961	COVER RR L., CRANK CASE.....	1	1	1	1
* STATOR, COMP,		3	11395-GBJ-731	GASKET L CRANK CASE COVER.....	-	-	1	1
* FLYWHEEL, COMP,	0.3	4	31100-KWH-961	A.C.GEN. ASSY.	-	-	1	1
* OIL SEAL, 18.9 X 30 X 5		5	31110-KWH-961	FLYWHEEL, COMP.....	-	-	1	1
* O-RING, 107 X 2		6	31120-KWH-961	STATOR, COMP.....	1	1	1	1
		7	32961-KST-940	CLAMPER ACG CORD.....	1	1	1	1
		8	32981-GB4-780	GROMMET NEUTRAL SWICTH CORD	1	1	1	1
		9	90083-KVH-900	BOLT KNOCK 5MM	1	1	2	2
		10	90084-KWH-960	CAP 14MM.....	1	1	1	1
		11	90087-KWH-960	CAP 30 MM.....	1	1	1	1
		12	90410-HC4-000	WASHER 10MM.....	1	1	1	1
		13	90702-GB6-910	PIN, DOWEL 8 X12.....	1	1	2	2
		14	91303-377-000	O-RING 13.8 X 2.5.....	1	1	1	1
		15	91356-KGH-901	O-RING 30MM	1	1	1	1
		16	94050-10000	NUT, FLANGE, 10 MM.....	1	1	1	1
		17	96001-06016-00	BOLT, FLANGE, SH., 6X16.....	1	1	1	1
		18	96001-06020-00	BOLT, FLANGE, SH. 6X20.....	1	1	2	2
		19	96001-06028-00	BOLT, FLANGE, SH. 6X28.....	1	1	2	2
		20	96001-06032-00	BOLT FLANGE, SH. 6X32	1	1	2	2

E-7A
LEFT CRANKCASE COVER/
A.C. GEN. ASSY. (SELF START)

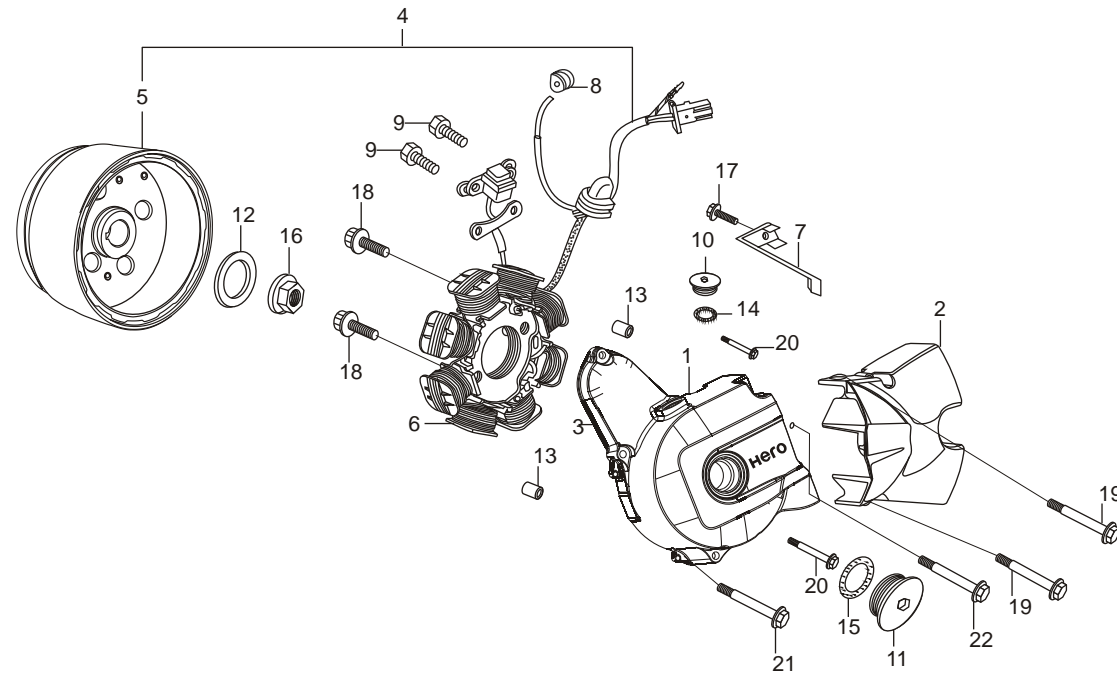

Service Item	F.R.T.	Ref. No.	Part No.	Description	Reqd. No. SPLENDOR PRO			
					DRUM			
					KICK		SELF	
					SPOKE	CAST	SPOKE	CAST
* COVER L. CRANKCASE	0.1	20	96001-06050-00	BOLT, FLANGE, SH. 6X50.....	-	-	1	1
* A.C.GEN.ASSY,	0.5	21	96001-06070-00	BOLT, FLANGE SH. 6X70.....	1	1	1	1
* STATOR, COMP,								
* FLYWHEEL, COMP,	0.3							
* OIL SEAL, 18.9 X 30 X 5								
* O-RING, 107 X 2								

E - 7 B STARTING CLUTCH

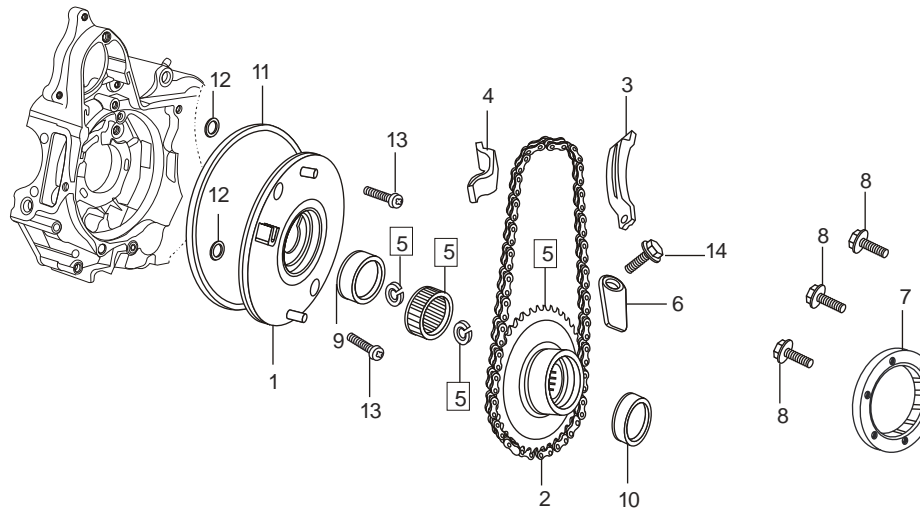

Service Item	F.R.T.	Ref. No.	Part No.	Description	Reqd. No. SPLENDOR PRO			
					DRUM			
					KICK		SELF	
					SPOKE	CAST	SPOKE	CAST
* COVER L. CRANKCASE	0.1	1	11321-KWA-940	PLATE OIL SEPARATE.....	-	1	-	1
* A.C.GEN.ASSY,	0.5	2	28101-KWA-940	CHAIN STARTING	-	1	-	1
* STATOR, COMP,		3	28102-KWA-940	GUIDE STARTER CHAIN	-	1	-	1
* FLYWHEEL, COMP,	0.3	4	28103-GB4-700	PROTECTOR STARTER CHAIN	-	1	-	1
* OIL SEAL, 18.9 X 30 X 5		5	28110-AAD-H40	SPROCKET COMP., STARTING	-	1	-	1
* O-RING, 107 X 2		6	28117-KFL-850	SET PLATE, STARTING SPROCKET.....	-	1	-	1
		7	28120-KWA-942	OUTER COMP. STARTING CLUTCH.....	-	1	-	1
		8	90085-KWA-940	BOLT SOCKET 6 MM	-	3	-	3
		9	91201-GBG-900	OIL SEAL 30X42X4.5.....	-	1	-	1
		10	91204-GBG-850	OIL SEAL 18.9X28X5.....	-	1	-	1
		11	91301-035-000	O-RING 107X2	-	1	-	1
		12	91317-171-000	O-RING 6X1.7	-	2	-	2
		13	93600-06016-0A	SCREW FLAT 6X16.....	-	2	-	2
		14	96001-06010-00	BOLT FLANGE SH.6X10	-	1	-	1

E-7C STARTING MOTOR

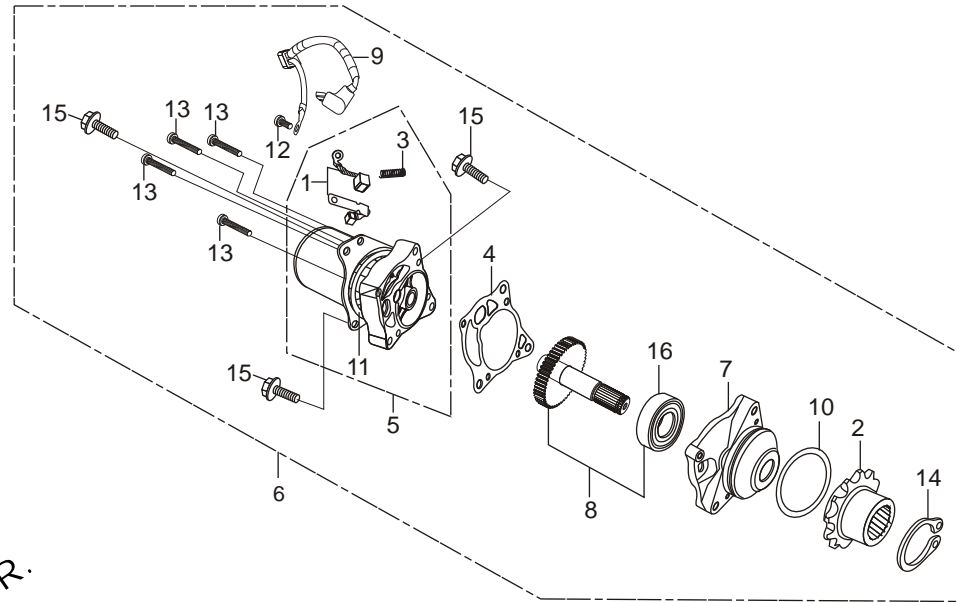

Service Item	F.R.T.	Ref. No.	Part No.	Description	Reqd. No. SPLENDOR PRO			
					DRUM			
					KICK		SELF	
					SPOKE	CAST	SPOKE	CAST
* COVER L. CRANKCASE	0.1	1	31201-KG8-004	BRUSH, SET.....	-	-	1	1
* A.C.GEN.ASSY,	0.5	2	31202-GB2-700L	SPROCKET	-	-	1	1
* STATOR, COMP,		3	31204-KG8-004	SPRING, BRUSH.....	-	-	2	2
* FLYWHEEL, COMP,	0.3	4	31205-KWA-941	PACKING	-	-	1	1
* OIL SEAL, 18.9 X 30 X 5		5	31208-KWA-941	MOTOR ONLY	-	-	1	1
* O-RING, 107 X 2		6	31210-KWA-941	MOTOR UNIT STARTER	-	-	1	1
		7	31211-KWA-941	CASE 'A' FRONT	-	-	1	1
		8	31213-GB4-701L	GEAR COMP., DRIVEN	-	-	1	1
		9	32410-KVH-871	SUB HARNESS 'A'	-	-	1	1
		10	91308-GB4-701L	O-RING A	-	-	1	1
		11	91309-GB2-701L	O-RING B	-	-	1	1
		12	93892-04006-08L	SCREW, WASH., 4X6	-	-	1	1
		13	93892-05030-08L	SCREW, WASH., 5X30	-	-	4	4
		14	94510-12000L	CIRCLIP, EXTERNAL, 12MM	-	-	1	1
		15	96001-06045-00	BOLT FLANGE SH. 6X45	-	-	3	3
		16	96120-60010-10L	BEARING, BALL RADIAL	-	-	1	1

E - 8 CRANK CASE/OIL PUMP

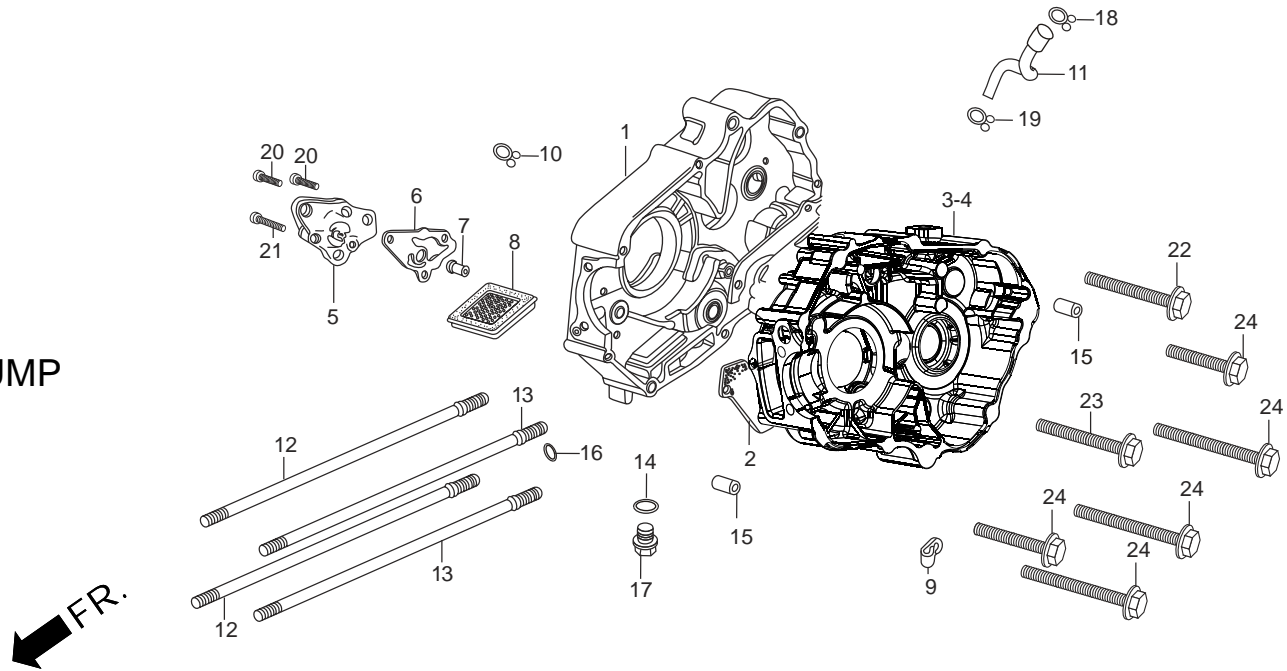

Service Item	F.R.T.	Ref. No.	Part No.	Description	Reqd. No. SPLENDOR PRO			
					DRUM			
					KICK		SELF	
					SPOKE	CAST	SPOKE	CAST
* CRANK CASE COMP, 'R'	*4.0	1	11100-KWH-960	CRANK CASE COMP.RIGHT(BLK)	1	1	1	1
* GASKET, CRANK CASE	*3.6	2	11191-GW8-681	GASKET CRANK CASE	1	1	1	1
* CRANK CASE COMP, 'L'	*4.4	3	11200-KWH-960	CRANK CASE COMP. LEFT(BLK)	1	1	-	-
* SCREEN, OIL FILTER	0.6	4	11200-KWH-970	CRANK CASE COMP. LEFT(BLK)	-	-	1	1
* BOLT, CYLINDER STUD	1.1	5	15100-KCC-900	PUMP ASSY.OIL	1	1	1	1
(ADD 0.1 FOR EACH)		6	15119-178-000	GASKET OIL PUMP BODY	1	1	1	1
* PUMP ASSY, OIL		7	15384-178-000	PIVOT OIL PUMP	1	1	1	1
(INC. RELATIVE PART)		8	15421-035-010	SCREEN OIL FILTER	1	1	1	1
		9	16236-045-010	CLAMPER OVER FLOW PIPE	1	1	1	1
		10	17316-611-000	CLIP BREATHER TUBE	1	1	1	1
		11	17371-KWH-970	TUBE BREATHER	1	1	1	1
		12	90031-GF6-000R	BOLT A CYL.STUD,6X198X7	2	2	2	2
		13	90032-GF6-000R	BOLT B CYL.STUB,6X205.5X7	2	2	2	2
		14	90407-259-000	DRAIN COCK PACKING	1	1	1	1
		15	90703-HC4-000	DOWEL PIN 10X14	2	2	2	2
		16	91303-GF6-000	PACKING RUBBER 16 MM	1	1	1	1
		17	92800-12000-00	DRAIN PLUG BOLT	1	1	1	1
		18	95002-02100	CLIP B 10 TUBE	1	1	1	1
		19	95002-80000	CLIP C12 TUBE	1	1	1	1

E - 8 CRANK CASE/OIL PUMP

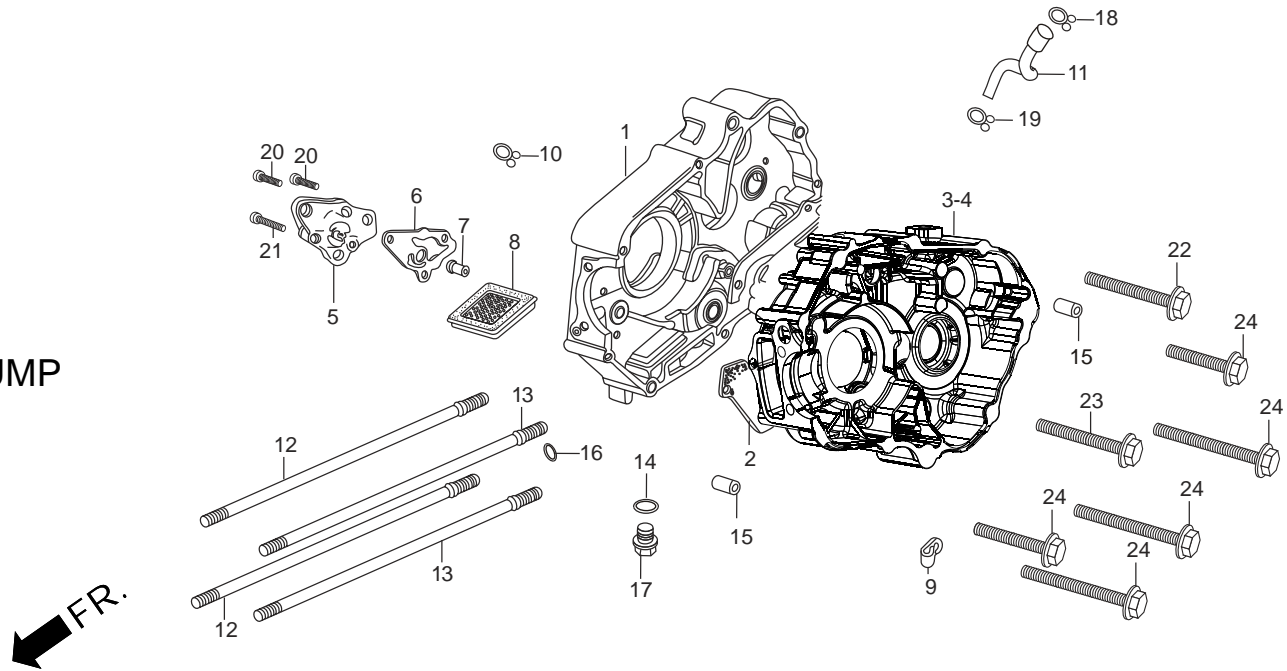

Service Item	F.R.T.	Ref. No.	Part No.	Description	Reqd. No. SPLENDOR PRO			
					DRUM			
					KICK		SELF	
					SPOKE	CAST	SPOKE	CAST
* CRANK CASE COMP, 'R'	*4.0	20	96001-06016-00	BOLT FLANGE SH.6X16	2	2	2	2
* GASKET, CRANK CASE	*3.6	21	96001-06025-00	BOLT FLANGE SH.6X25	1	1	1	1
* CRANK CASE COMP, 'L'	*4.4	22	96001-06050-00	BOLT FLANGE SH.6X50	1	1	1	1
* SCREEN, OIL FILTER	0.6	23	96001-06060-00	BOLT FLANGE SH.6X60	2	2	2	2
* BOLT, CYLINDER STUD	1.1	24	96001-06065-00	BOLT FLANGE SH.6X65	4	4	4	4
(ADD 0.1 FOR EACH)								
* PUMP ASSY., OIL								
(INC. RELATIVE PART)								

E - 9 CRANKSHAFT/PISTON

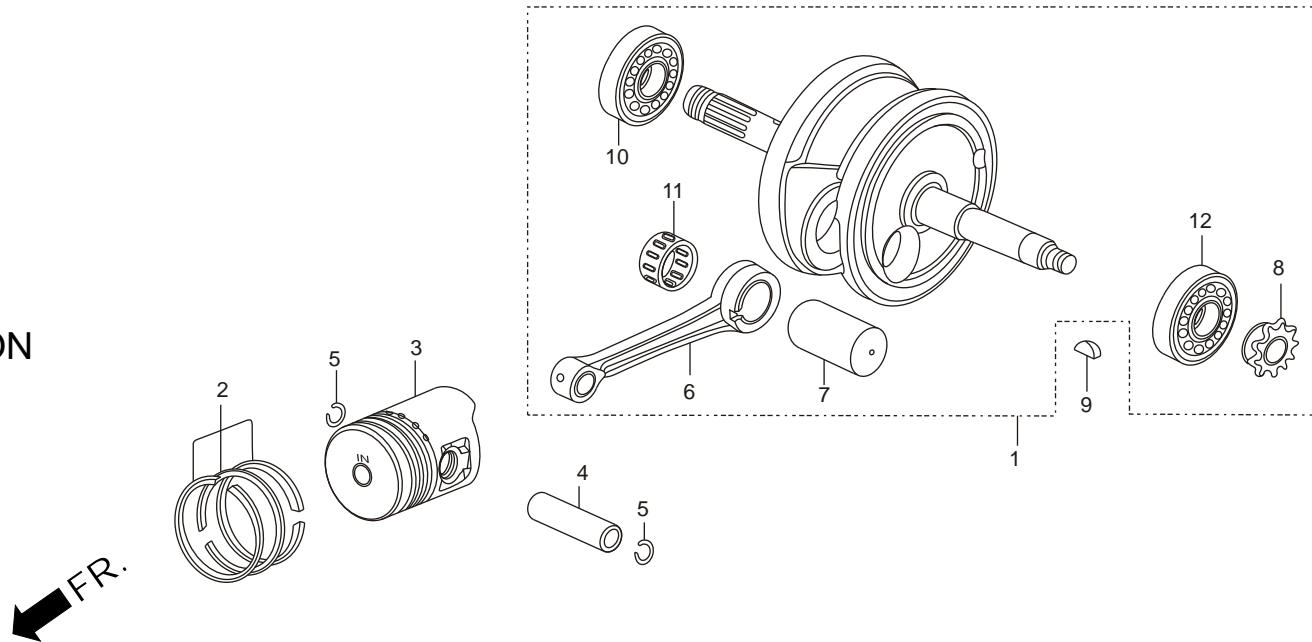

Service Item	F.R.T.	Ref. No.	Part No.	Description	Reqd. No. SPLENDOR PRO			
					DRUM			
					KICK		SELF	
					SPOKE	CAST	SPOKE	CAST
* CRANKSHAFT COMP.,.....	4.0	1	13000-AAC-H40	CRANK SHAFT COMP.,	1	1	1	1
* RING SET, PISTON	1.3	2	13011-KCC-942	RING SET, PISTON (STD)	1	1	1	1
* PISTON			13012-KCC-942	RING SET, PISTON (0.25)	(1)	(1)	(1)	(1)
* PIN, PISTON	1.2		13013-KCC-942	RING SET, PISTON (0.50)	(1)	(1)	(1)	(1)
* ROD, CONNECTING (ACTUAL TIME) (INC. RELATIVE PART).....			13014-KCC-942	RING SET, PISTON (0.75)	(1)	(1)	(1)	(1)
* BEARING, RADIAL BALL, 6304	4.2 (ADD 0.2 FOR EACH)		13015-KCC-942	RING SET, PISTON (1.00)	(1)	(1)	(1)	(1)
		3	13101-KCC-901	PISTON (STD)	1	1	1	1
			13102-KCC-315	PISTON (0.25)	(1)	(1)	(1)	(1)
			13103-KCC-315	PISTON (0.50)	(1)	(1)	(1)	(1)
			13104-KCC-315	PISTON (0.75)	(1)	(1)	(1)	(1)
			13105-KCC-315	PISTON (1.00)	(1)	(1)	(1)	(1)
		4	13111-087-000	PIN, PISTON	1	1	1	1
		5	13115-001-000	CLIP, PISTON PIN	2	2	2	2
		6	13201-GF6-300	ROD, CONNECTING	1	1	1	1
		7	13381-KCC-900L	PIN, CRANK	1	1	1	1
		8	14311-035-000	SPROCKET, TIMING	1	1	1	1
		9	90741-KFB-000	KEY, WOODRUFF, 4MM	1	1	1	1
		10	91101-AAC-H40	BEARING, CONN. ROD (RED) OR	1	1	1	1
		11	91102-AAC-H40	BEARING, CONN. ROD (BLUE) OR	1	1	1	1
		12	91103-AAC-H40	BEARING, CONN. ROD (WHITE)	1	1	1	1

E - 10 TRANSMISSION

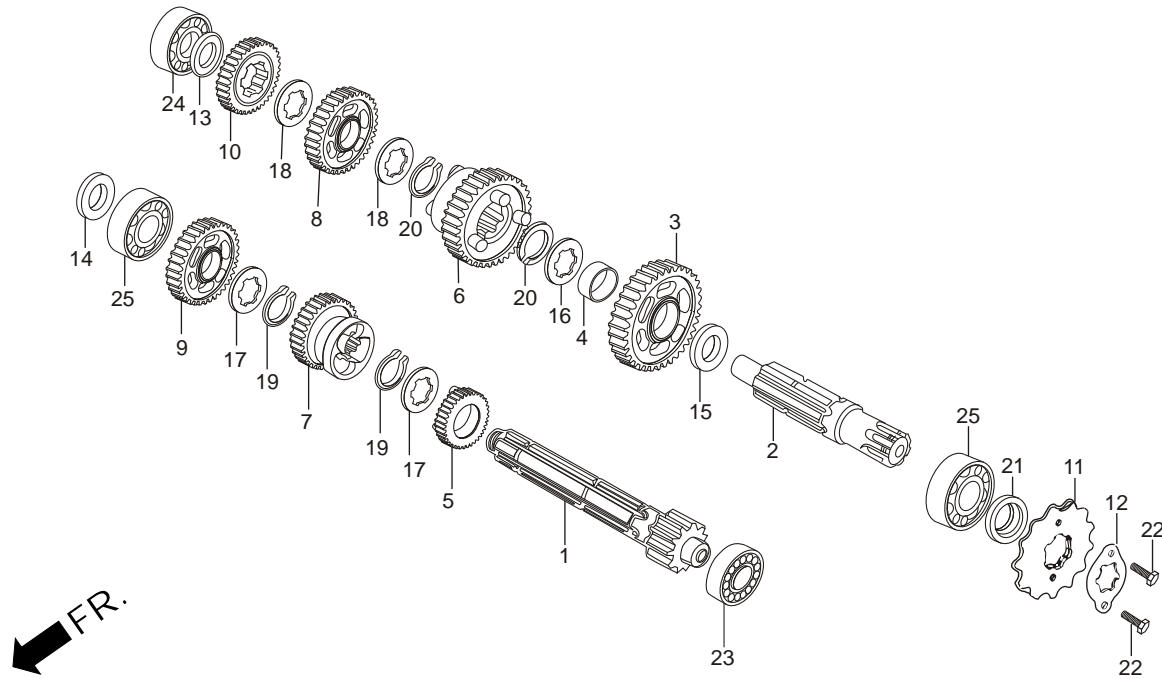

Service Item	F.R.T.	Ref. No.	Part No.	Description	Reqd. No. SPLENDOR PRO			
					DRUM			
					KICK		SELF	
					SPOKE	CAST	SPOKE	CAST
*MAINSHAFT	3.8	1	23211-GF6-000	MAINSHAFT (11T)	1	1	1	1
(INC. RELATIVE PART)		2	23221-GF6-000	COUNTERSHAFT	1	1	1	1
*COUNTERSHAFT		3	23421-GB4-770	GEAR, COUNTERSHAFT LOW	1	1	1	1
(INC. RELATIVE PART)		4	23422-GB4-770	BUSH, 20X9	1	1	1	1
(WHEN SERVICING COMP., UNIT)		5	23431-GN5-910	GEAR, MAINSHAFT SECOND	1	1	1	1
F.R.T. IS 4.0		6	23441-GB4-770	GEAR, COUNTERSHAFT SECOND	1	1	1	1
*SPROCKET, DRIVE	0.2	7	23451-GK4-761	GEAR, MAINSHAFT THIRD	1	1	1	1
		8	23461-GK4-760	GEAR, COUNTERSHAFT THIRD	1	1	1	1
		9	23471-GN5-910	GEAR, MAINSHAFT FOURTH	1	1	1	1
		10	23481-HF7-000	GEAR, COUNTERSHAFT FOURTH	1	1	1	1
		11	23801-178-000	SPROCKET, DRIVE	1	1	1	1
		12	23802-040-000	PLATE, DRIVE SPROCKET FIXING	1	1	1	1
		13	90451-GF6-000	WASHER, THRUST, 12MM	1	1	1	1
		14	90451-198-000	WASHER, THRUST, 17MM	1	1	1	1
		15	90452-GB4-770	WASHER, THRUST, 17MM	1	1	1	1
		16	90461-GB4-770	WASHER, SPLINE, 20 X 1.2	1	1	1	1
		17	90461-035-000	WASHER, SPLINE, 17MM	2	2	2	2
		18	90461-459-000	WASHER, SPLINE, 20MM	2	2	2	2
		19	90601-001-000	CIRCLIP, 17MM	2	2	2	2
		20	90601-459-000	CIRCLIP, 20MM	2	2	2	2

E - 10 TRANSMISSION

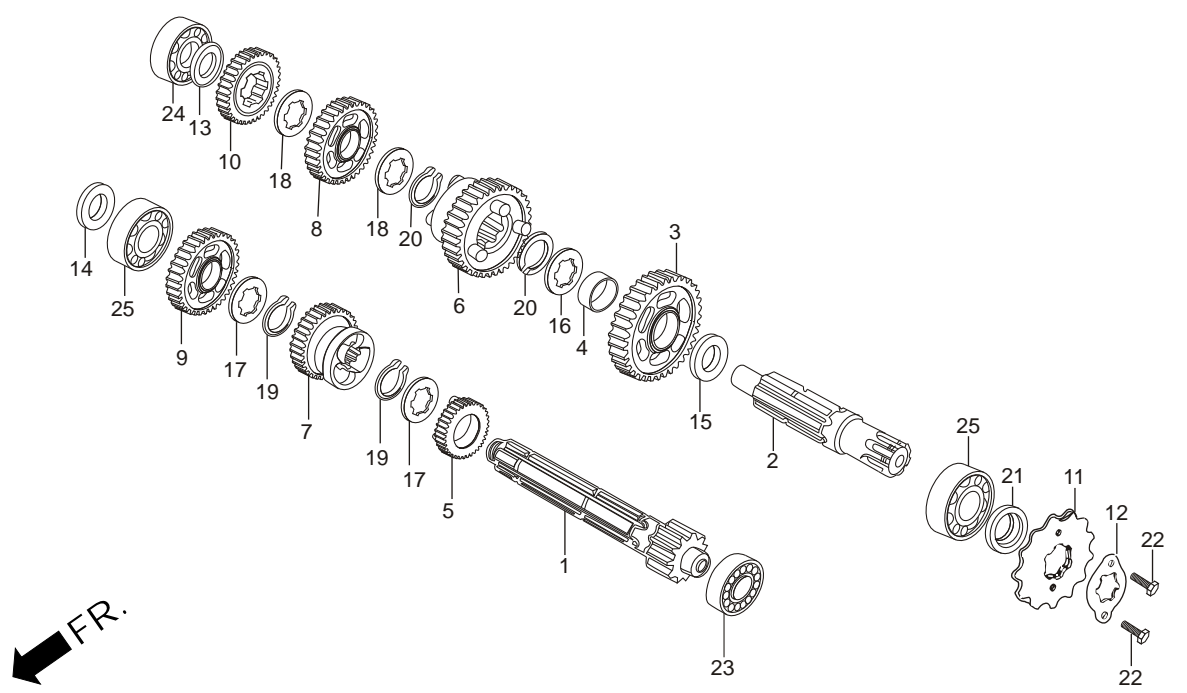

Service Item	F.R.T.	Ref. No.	Part No.	Description	Reqd. No. SPLENDOR PRO			
					DRUM			
					KICK		SELF	
					SPOKE	CAST	SPOKE	CAST
*MAINSHAFT3.8 (INC. RELATIVE PART)		21	91203-GB5-760	OIL SEAL, 17X29X5	1	1	1	1
*COUNTERSHAFT..... (INC. RELATIVE PART)		22	92000-06008-0H	BOLT, HEX., 6 X 8	2	2	2	2
(WHEN SERVICING COMP., UNIT)		23	96100-60010-00	BEARING, RADIAL BALL, 6001	1	1	1	1
F.R.T. IS 4.0		24	96100-62010-00	BEARING, RADIAL BALL, 6201	1	1	1	1
*SPROCKET, DRIVE.....0.2		25	96100-62030-00	BEARING, RADIAL BALL, 6203	2	2	2	2

E - 11 KICK STARTER

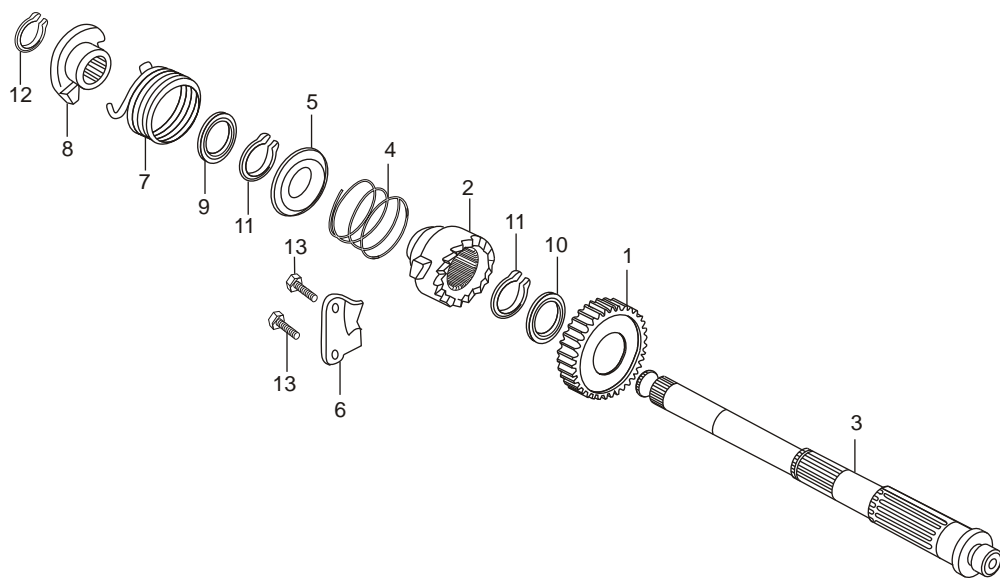

Service Item	F.R.T.	Ref. No.	Part No.	Description	Reqd. No. SPLENDOR PRO			
					DRUM			
					KICK		SELF	
					SPOKE	CAST	SPOKE	CAST
*PINION, KICK STARTER	3.7	1	28211-GF6-000	PINION, KICK STARTER	1	1	1	1
*SPINDLE, KICK STARTER		2	28221-198-010	RATCHET, KICK STARTER	1	1	1	1
(INC. RELATIVE PART)		3	28251-GF6-000	SPINDLE, KICK STARTER	1	1	1	1
*SPRING, KICK STARTER	1.1	4	28253-397-000	SPRING, KICK STARTER RATCHET	1	1	1	1
(INC. RELATIVE PART)		5	28254-198-000	RETAINER, RATCHET SPRING	1	1	1	1
		6	28256-198-000	PLATE, RATCHET GUIDE	1	1	1	1
		7	28261-198-000	SPRING, KICK STARTER	1	1	1	1
		8	28262-198-000	RETAINER, KICK SPRING	1	1	1	1
		9	90452-115-000	WASHER, 17MM	1	1	1	1
		10	90454-107-000	WASHER, THRUST, 20MM	1	1	1	1
		11	90601-459-000	CIRCLIP, 20MM	2	2	2	2
		12	94510-16000	CIRCLIP, EXARNAL, 16MM	1	1	1	1
		13	95701-06020-00	BOLT, FLANGE 6X20	2	2	2	2

E - 12 GEARSHIFT

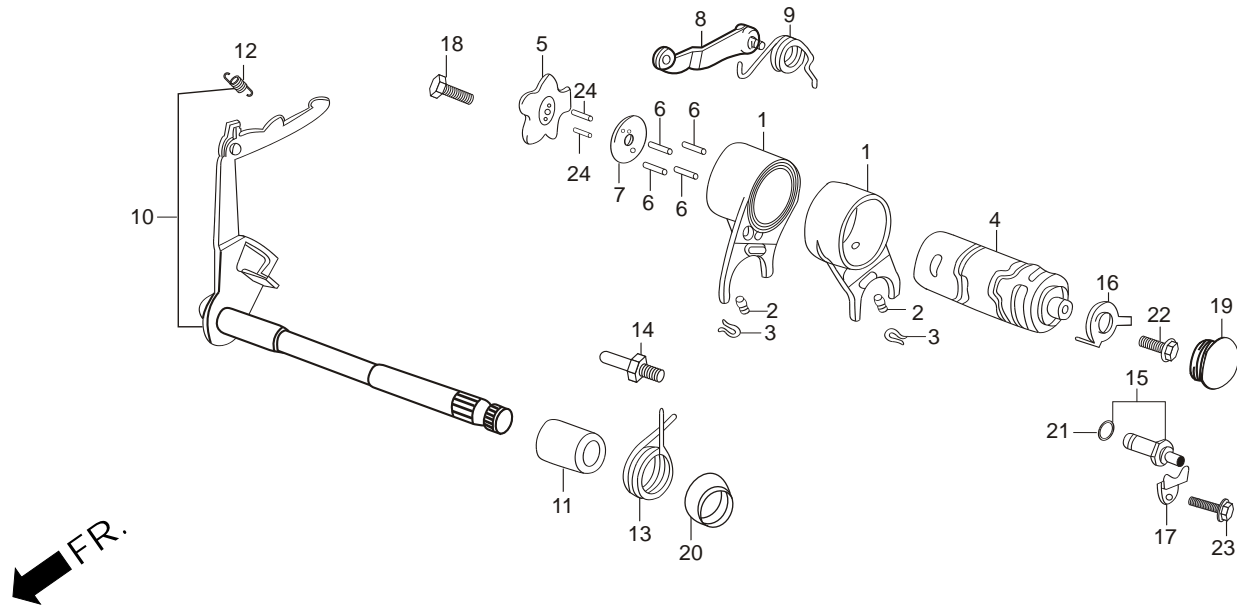

Service Item	F.R.T.	Ref. No.	Part No.	Description	Reqd. No. SPLENDOR PRO			
					DRUM			
					KICK		SELF	
					SPOKE	CAST	SPOKE	CAST
*FOR GEAR SHIFT3.8 (ONE OR ALL).....		1	24211-GF6-000R	FORK, GEAR SHIFT	2	2	2	2
		2	24261-121-742	PIN, GEAR SHIFT FORK GUIDE.....	2	2	2	2
*DRUM, GEAR SHIFT		3	24263-028-000	CLIP, GEAR SHIFT FORK GUIDE.....	2	2	2	2
*PLATE, SHIFT DRUM STOPPER		4	24301-KWA-930	DRUM, GEAR SHIFT.....	1	2	2	2
*ARM COMP., SHIFT DRUM STOPPER (INC. RELATIVE PART).....		5	24411-198-900	PLATE, SHIFT DRUM STOPPER.....	1	1	1	1
*SINDLE COMP., GEAR SHIFT1.2 (INC. RELATIVE PART).....		6	24421-200-000	PIN, GEAR SHIFT DRUM.....	4	4	4	4
		7	24425-198-900	PLATE, SHIFT DRUM SIDE	1	1	1	1
		8	24430-198-900	ARM COMP., SHIFT DRUM STOPPER	1	1	1	1
		9	24435-GB4-770	SPRING, GEAR SHIFT DRUM STOPPER.....	1	1	1	1
		10	24610-KST-940	SPINDLE COMP., GEAR SHIFT.....	1	1	1	1
		11	24639-035-000L	COLLAR, 12.2MM.....	1	1	1	1
		12	24641-041-000	SPRING, GEAR SHIFT ARM.....	1	1	1	1
		13	24651-035-000L	SPRING, GEAR SHIFT, RETURN	1	1	1	1
		14	24652-035-000	PIN, SHIFT RETURN SPRING.....	1	1	1	1
		15	35750-001-000	CONTACT ASSY., NEUTRAL SWITCH	1	1	1	1
		16	35753-035-010	ROTOR, NEUTRAL SWITCH	1	1	1	1
		17	35755-001-000	PLATE, CONTACT FIXING.....	1	1	1	1
		18	90071-171-010	BOLT, KNOCK, 6MM.....	1	1	1	1
		19	90801-035-000	PLUG, RUBBER, 19 MM	1	1	1	1

E - 12 GEARSHIFT

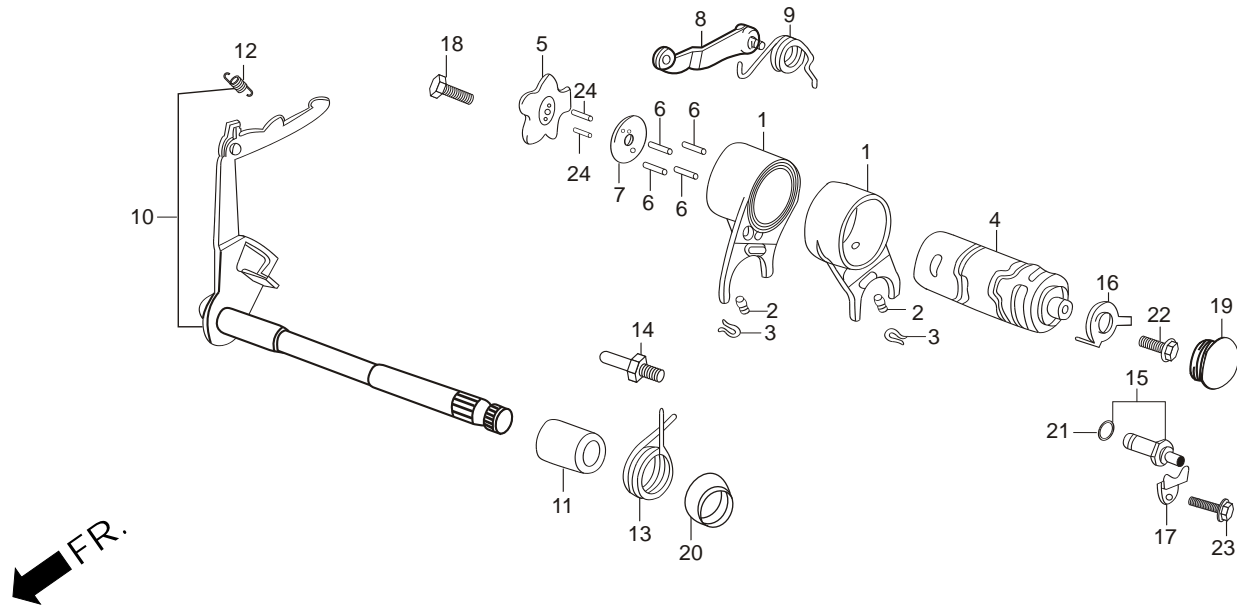

Service Item	F.R.T.	Ref. No.	Part No.	Description	Reqd. No. SPLENDOR PRO			
					DRUM			
					KICK		SELF	
					SPOKE	CAST	SPOKE	CAST
*FOR GEAR SHIFT3.8 (ONE OR ALL).....		20	91208-KB4-670	OIL SEAL, 11.6X24X10	1	1	1	1
*DRUM, GEAR SHIFT		21	91312-107-000	O-RING 7 X 1.7	1	1	1	1
*PLATE, SHIFT DRUM STOPPER		22	90022-GFP-900	BOLT WASH 6X16.....	1	1	1	1
*ARM COMP., SHIFT DRUM STOPPER (INC. RELATIVE PART).....		23	96001-06012-00	BOLT FLANGE SH 6X12.....	1	1	1	1
*SINDLE COMP., GEAR SHIFT1.2 (INC. RELATIVE PART).....		24	96220-30085	ROLLER, 3X8.5.....	2	2	2	2
*CONTACT ASSY.....								
NEUTRAL SWITCH.....0.2								

E - 13 CARBURETTOR

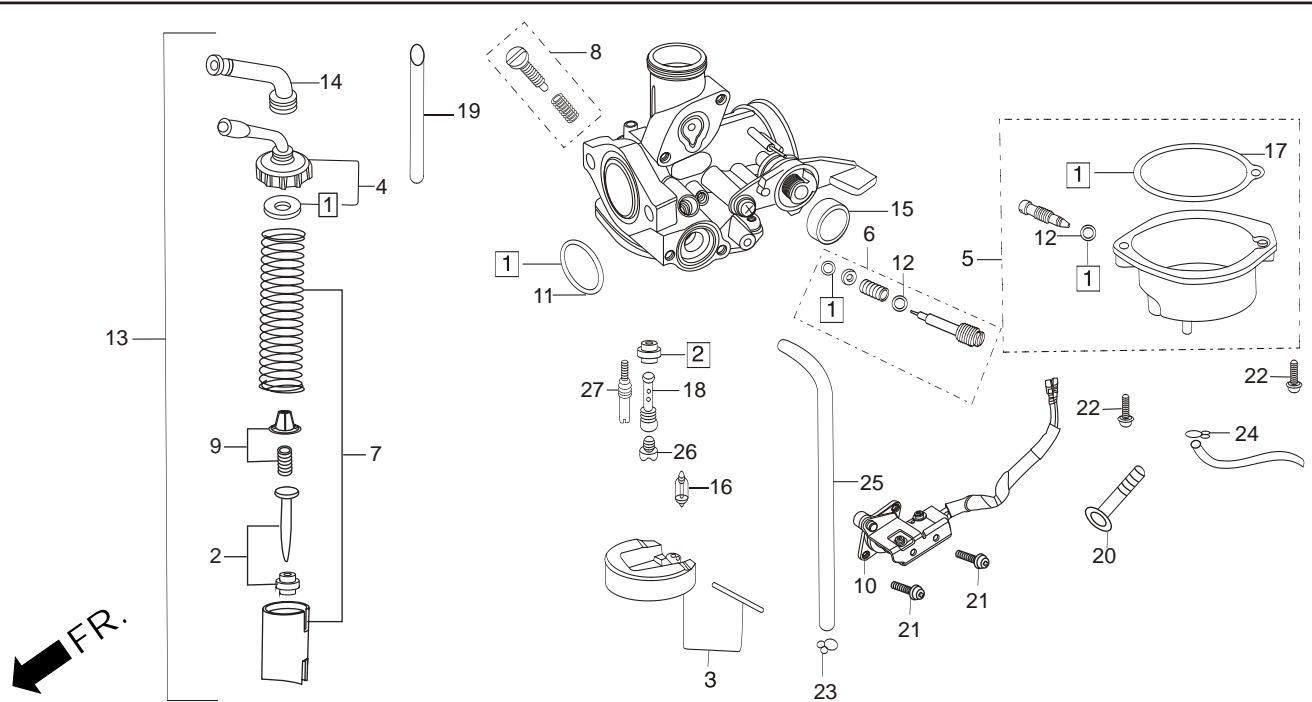

Service Item	F.R.T.	Ref. No.	Part No.	Description	Reqd. No. SPLENDOR PRO			
					DRUM			
					KICK		SELF	
					SPOKE	CAST	SPOKE	CAST
* NEEDLE SET, JET.....0.5		1	16010-KWA-931	GASKET, SET	1	1	1	1
* CARBURETTOR ASSY		2	16012-KWA-931	NEEDLE SET, JET	1	1	1	1
* FLOAT SET	0.4	3	16013-KRB-901	FLOAT, SET	1	1	1	1
* VALVE COMP., FLOAT JET, MAIN.....		4	16014-KTR-A01	TOP, SET.....	1	1	1	1
* TOP SET	0.2	5	16015-KVW-921	CHAMBER SET, FLOAT.....	1	1	1	1
* CHAMBER SET, FLOAT		6	16016-KPH-651	SCREW SET 'A'	1	1	1	1
* VALVE SET, THROTTLE.....0.3		7	16022-KWA-931	VALVE SET, THROTTLE	1	1	1	1
		8	16028-KST-941	SCREW SET 'B'	1	1	1	1
		9	16037-KPH-901	PLATE SET VALVE	1	1	1	1
		10	16060-KWA-933	SWITCH ASSY., THROTTLE	1	1	1	1
		11	16075-KTC-901	O-RING,.....	1	1	1	1
		12	16076-KPL-901	O-RING,.....	1	1	1	1
		13	16100-KWH-961	CARBURETTOR ASSY.,	1	1	1	1
		14	16118-KTR-A01	CAP, CABLE SEALING	1	1	1	1
		15	16148-KPL-901	CAP, CHOKE DUST	1	1	1	1
		16	16155-KRS-861	VALVE COMP., FLOAT	1	1	1	1
		17	16163-GFP-901	GASKET, FLOAT CHAMBER	1	1	1	1
		18	16165-KWA-931	HOLDER NEEDLE JET.....	1	1	1	1
		19	16199-KWA-931	TUBE, AIR VENT.....	1	1	1	1
		20	35701-KWA-931	BAND,	1	1	1	1

E - 13 CARBURETTOR

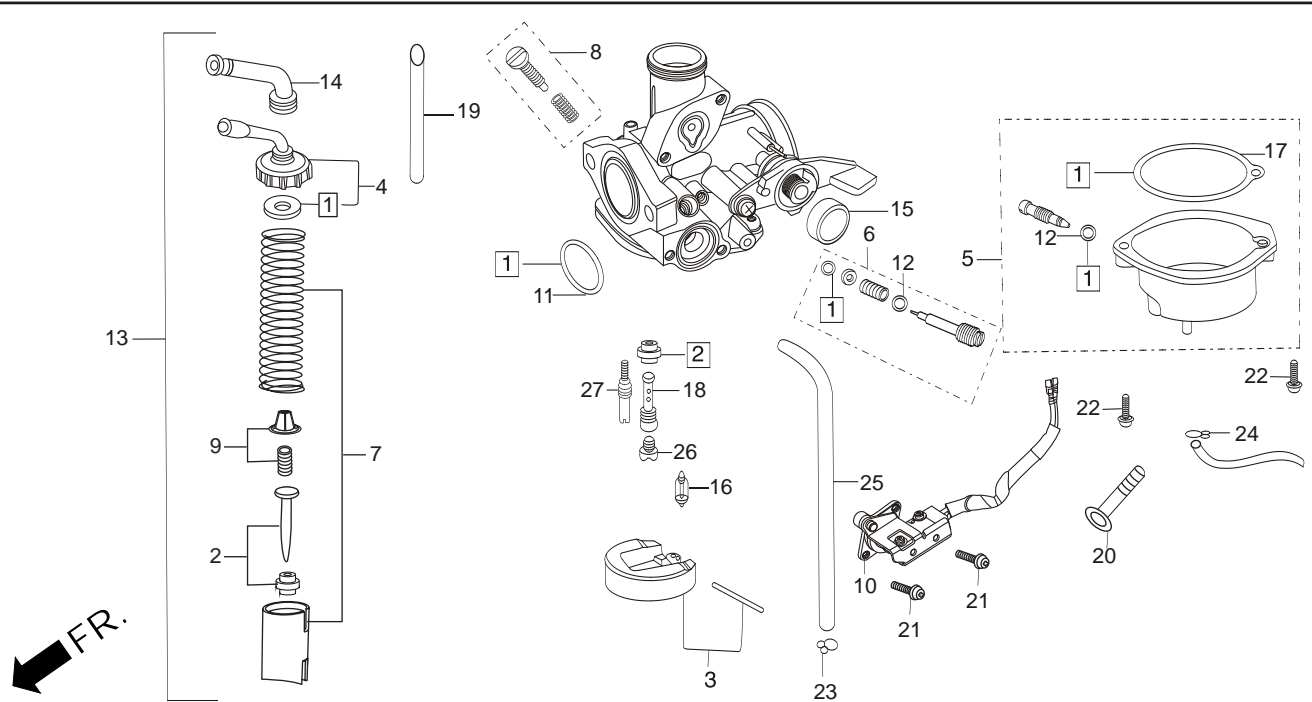

Service Item	F.R.T.	Ref. No.	Part No.	Description	Reqd. No. SPLENDOR PRO			
					DRUM			
					KICK		SELF	
					SPOKE	CAST	SPOKE	CAST
* NEEDLE SET, JET.....	0.5	21	93892-04010-10	SCREW, WASH. 4 X10	2	2	2	2
* CARBURETTOR ASSY		22	93892-04014-08	SCREW, WASH. 4 X14	2	2	2	2
* FLOAT SET	0.4	23	95002-02089	CLIP, B-1, 8 TUBE	1	1	1	1
* VALVE COMP., FLOAT JET, MAIN.....		24	95002-02659	CLIP, B-1, 6.5 TUBE	1	1	1	1
* TOP SET	0.2	25	95005-35260-50	TUBE 35 X 170.....	1	1	1	1
* CHAMBER SET, FLOAT								
* VALVE SET, THROTTLE.....	0.3	26	99101-KWA-1050	JET, MAIN #105.....	1	1	1	1
		27	99103-KTC-0350	JET, SLOW#35	1	1	1	1

FRAME GROUP

F - 1V HEADLIGHT / FR. VISOR

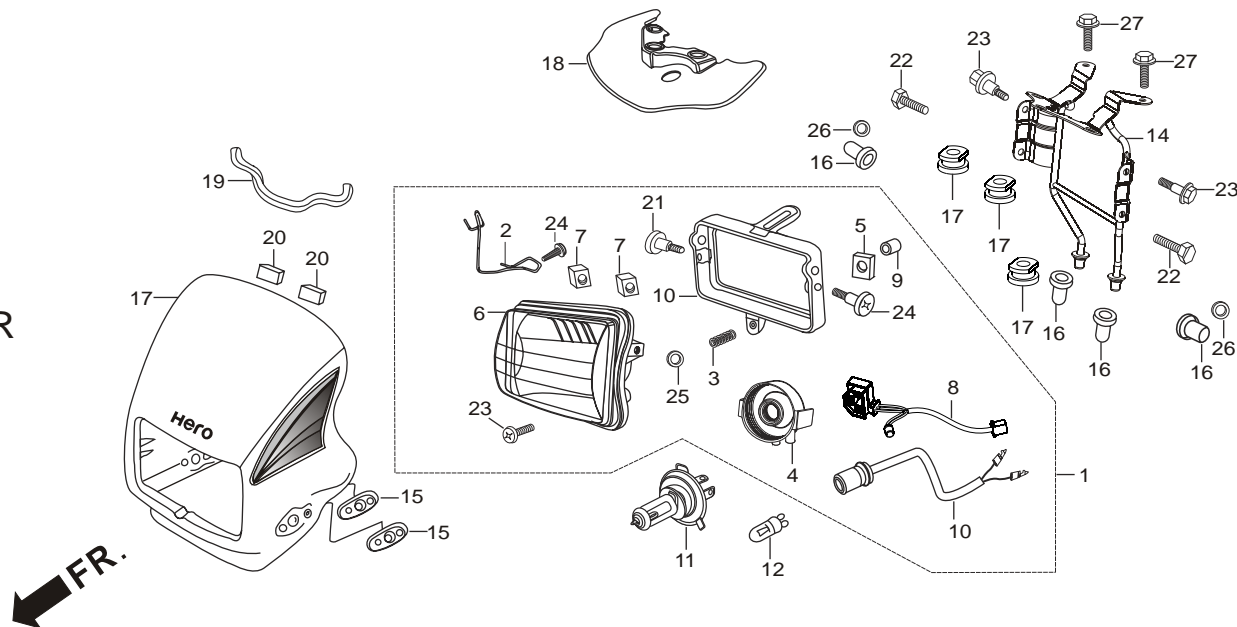

Service Item	F.R.T.	Ref. No.	Part No.	Description	Reqd. No. SPLENDOR PRO			
					DRUM			
					KICK		SELF	
					SPOKE	CAST	SPOKE	CAST
*LIGHT ASSY., HEAD	0.1	1	3310B-AAD-H00	LIGHT ASSY., HEAD (W/O BULB)	1	1	1	1
*UNIT HEADLIGHT		2	33100-S2K-003	SPRING, BULB HOLDER	1	1	1	1
(INC. RELATIVE PART)		3	33107-300-000	SPRING, BEAM ADJUSTER	1	1	1	1
*BULB, HEADLIGHT		4	33112-KWH-960	RUBBER COVER	1	1	1	1
*SOCKET ASSY., HEADLIGHT	0.2	5	33117-KB7-910	NUT, BEAM ADJUST	1	1	1	1
*SOCKET ASSY., POSITION LIGHT		6	33120-AAD-H00	UNIT, HEAD LIGHT	1	1	1	1
*STAY, HEADLIGHT BRACKET		7	33128-KCC-910	NUT, UNIT HOLDER	2	2	2	2
*PANEL, INNER		8	33130-KWH-960	SOCKET COMP., HEAD LIGHT	1	1	1	1
*SET, FR. VISOR		9	33136-426-830	COVER, SCREW, 4 MM	1	1	1	1
		10	33153-KCC-830	RING COMP., MOUNTING	1	1	1	1
		11	34901-KSP-910	BULB, HEADLIGHT (12V-35/35W)	1	1	1	1
		12	34908-GA7-700	BULB, WEDGE BASE (12V-3.0W)	1	1	1	1
		13	61311-KWH-970	STAY, HEADLIGHT BRACKET	1	1	1	1
		14	61312-KCC-900	PLATE, WINKER SET	2	2	2	2
		15	26131-149-300	BOOT, HEADLIGHT BRACKET	4	4	4	4
		16	80101-443-000	RUBBER RR. FENDER CUSHION	3	3	3	3
		17	83410-AAD-H70ZA	SET, FR.VISOR (BLACK-1)	1	1	1	1
			83410-AAD-H70ZB	SET, FR.VISOR (BLACK-2)	1	1	1	1

4

F - 1V HEADLIGHT / FR. VISOR

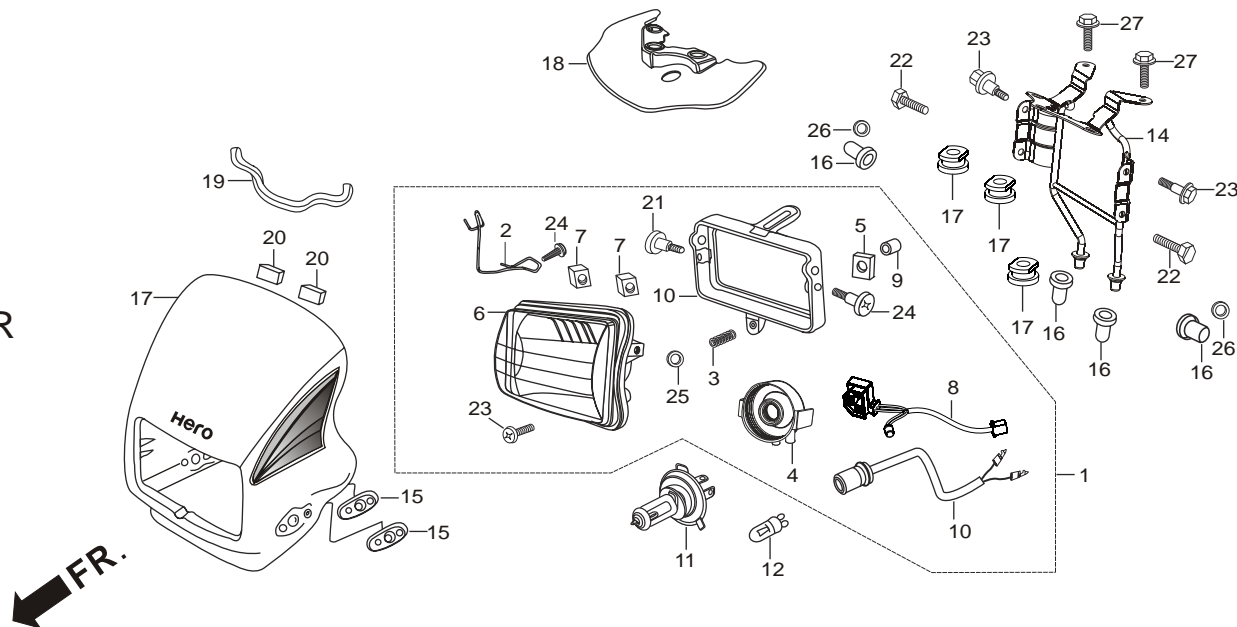

Service Item	F.R.T.	Ref. No.	Part No.	Description	Reqd. No. SPLENDOR PRO			
					DRUM			
					KICK		SELF	
					SPOKE	CAST	SPOKE	CAST
*LIGHT ASSY., HEAD	0.1	17	83410-AAD-H70ZC	SET, FR. VISOR (CLOUD SILVER ME.).....	1	1	1	1
*UNIT HEADLIGHT			83410-AAD-H70ZD	SET, FR. VISOR (CANDY BLAZING RED).....	1	1	1	1
(INC. RELATIVE PART)			83410-AAD-H70ZE	SET, FR. VISOR (EXCELLENT BLUE ME.).....	1	1	1	1
*BULB, HEADLIGHT			83410-AAD-H70ZF	SET, FR. VISOR (HI-GRANITE BLUE ME.).....	1	1	1	1
*SOCKET ASSY., HEADLIGHT	0.2		83410-AAD-H70ZG	SET, FR. VISOR (PALACE MAROON ME.).....	1	1	1	1
*SOCKET ASSY., POSITION LIGHT			83410-AAD-H70ZH	SET, FR. VISOR (HEAVY GRAY ME.).....	1	1	1	1
*STAY, HEADLIGHT BRACKET								
*PANEL, INNER		18	83402-KCC-900	PANEL, INNER.....	1	1	1	1
*SET, FR. VISOR		19	83403-KCC-830	CUSHION, SEAL VISOR FR.....	1	1	1	1
		20	83407-KCC-902	CUSHION, FR. VISOR.....	2	2	2	2
		21	90150-GN5-901	SCREW, SPECIAL, 5 X 10.....	2	2	2	2
		22	92000-08012-0A	BOLT, HEX., 8 X 12.....	2	2	2	2
		23	93500-04040-OH	SCREW, PAN, 4 X 40.....	1	1	1	1
		24	93901-34210	SCREW, TAPPING, 4 X 10	1	1	1	1
		25	94101-04800	WASHER, PLAIN, 4 MM	1	1	1	1
		26	94101-08000	WASHER, PLAIN, 8 MM	2	2	2	2
		27	96001-06016-07	BOLT, FLANGE, SH. 6 X 16.....	2	2	2	2

F - 2V SPEEDOMETER/CABLE/ KEY SET

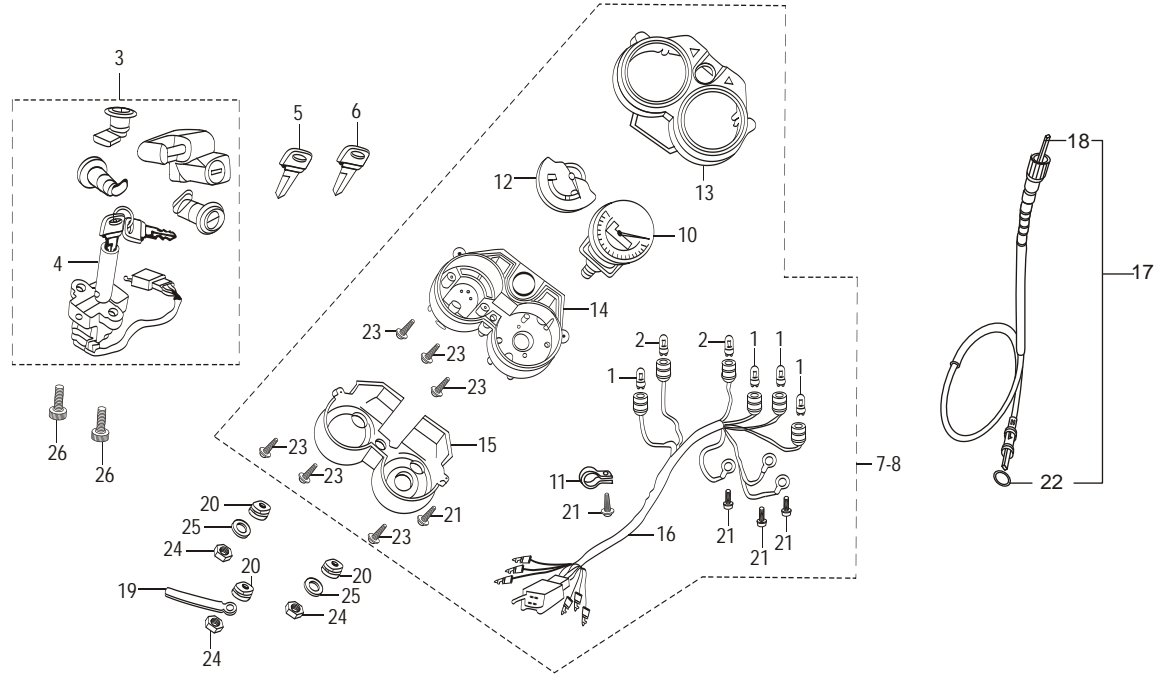

Service Item	F.R.T.	Ref. No.	Part No.	Description	Reqd. No. SPLENDOR PRO			
					DRUM			
					KICK		SELF	
					SPOKE	CAST	SPOKE	CAST
*KEY SET.....	1.1	1	34910-KWA-930	BULB WEDGE BASE (T10 12V1.7 W).....	4	4	4	4
*SWITCH ASSY., COMB. & LOCK.....	0.4	2	34920-KWA-930	BULB WEDGE BASE (T10 12V 3.0 W).....	2	2	2	2
*SPEEDOMETER ASSY.....	0.3	3	35010-AAD-H00	KEY SET	1	1	1	1
*SPEEDOMETER COMP.,.....	0.5	4	35100-AAD-H00	SWITCH ASSY., COMB. & LOCK	1	1	1	1
*CASE, UPPER ASSY.,.....		5	35121-KVH-850	KEY BLANK (TYPE-1).....	1	1	1	1
*CASE, UNDER ASSY.,.....		6	35122-KVH-850	KEY BLANK (TYPE-2).....	(1)	(1)	(1)	(1)
*SOCKET COMP.,.....		7	37100-AAD-H00	METER ASSY., COMB.	1	1	1	1
*CABLE COMP., SPEEDOMETER		8	37100-AAD-H63	METER ASSY., COMB.	1	1	1	1
*CABLE, INNER.....	0.1	9	37113-KWH-961	EMBLEM METER.....	1	1	1	1
		10	37210-AAD-H00	SPEEDOMETER COMP.....	1	1	1	1
		11	37215-MB6-830	CLAMP	1	1	1	1
		12	37300-AAD-H00	FUEL METER, COMP	1	1	1	1
		13	37610-KWH-961	CASE, UPPER ASSY.	1	1	1	1
		14	37612-KCC-900	CASE, UNDER	1	1	1	1
		15	37614-KCC-900	COVER, UNDER CASE	1	1	1	1
		16	37619-KWH-961	SOCKET COMP.	1	1	1	1
		17	44830-KWA-910	CABLE, COMP., SPEEDOMETER	1	1	1	1
		18	44831-KTC-900	CABLE, INNER.....	1	1	1	1
		19	61317-KCC-900	GUIDE 'A'	1	1	1	1
		20	80101-443-000	RUBBER, RR. FENDER CUSHION	3	3	3	3

**F - 2V
SPEEDOMETER/CABLE/
KEY SET**

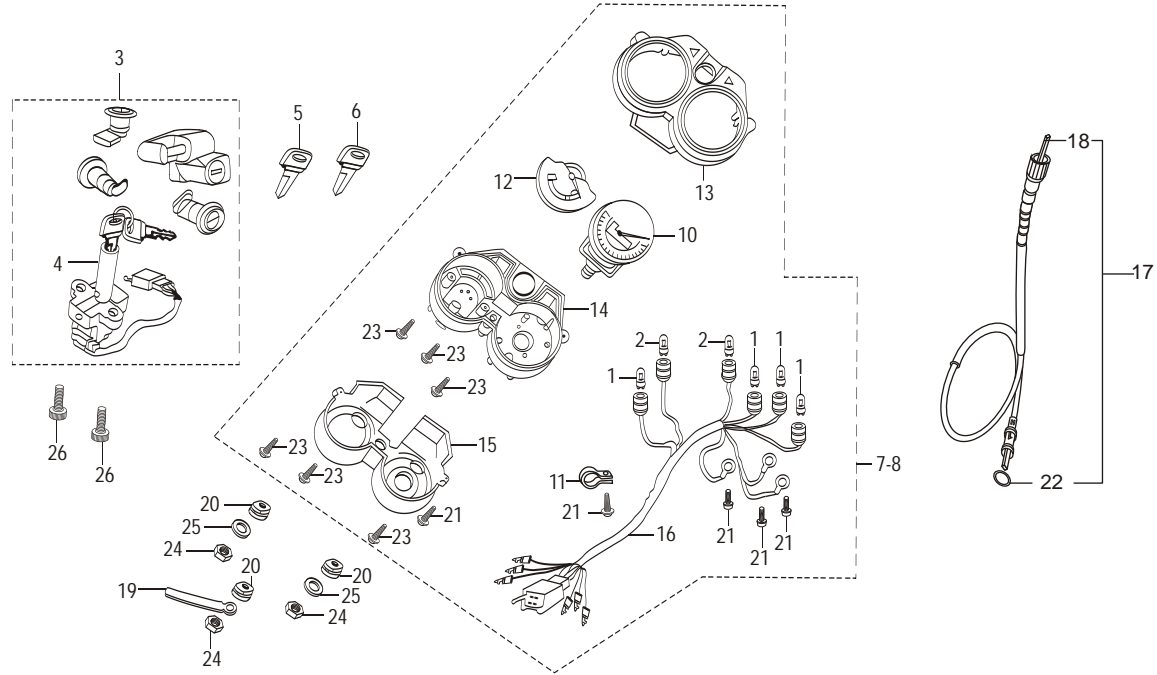

Service Item	F.R.T.	Ref. No.	Part No.	Description	Reqd. No. SPLENDOR PRO			
					DRUM			
					KICK		SELF	
					SPOKE	CAST	SPOKE	CAST
*KEY SET.....	1.1	21	90108-223-000	SCREW, WASH., 3X10	3	3	3	3
*SWITCH ASSY., COMB. & LOCK.....	0.4	22	91352-GAZ-930	'O' RING, 8.5X1.5	1	1	1	1
*SPEEDOMETER ASSY.....	0.3	23	93913-24320	SCREW, TAPPING, 4X14	8	8	8	8
*SPEEDOMETER COMP.,.....	0.5	24	94001-06070-0S	NUT, HEX., 6 MM	3	3	3	3
*CASE, UPPER ASSY.,.....		25	94103-06700	WASHER, PLAIN, 6 MM	2	2	2	2
*CASE, UNDER ASSY.,		26	96700-08020-00	BOLT, SOCKET 8 MM	2	2	2	2
*SOCKET COMP.,.....								
*CABLE COMP., SPEEDOMETER								
*CABLE, INNER.....	0.1							

F - 3
**HANDLE LEVER/SWITCH/
 CONTROL CABLE**

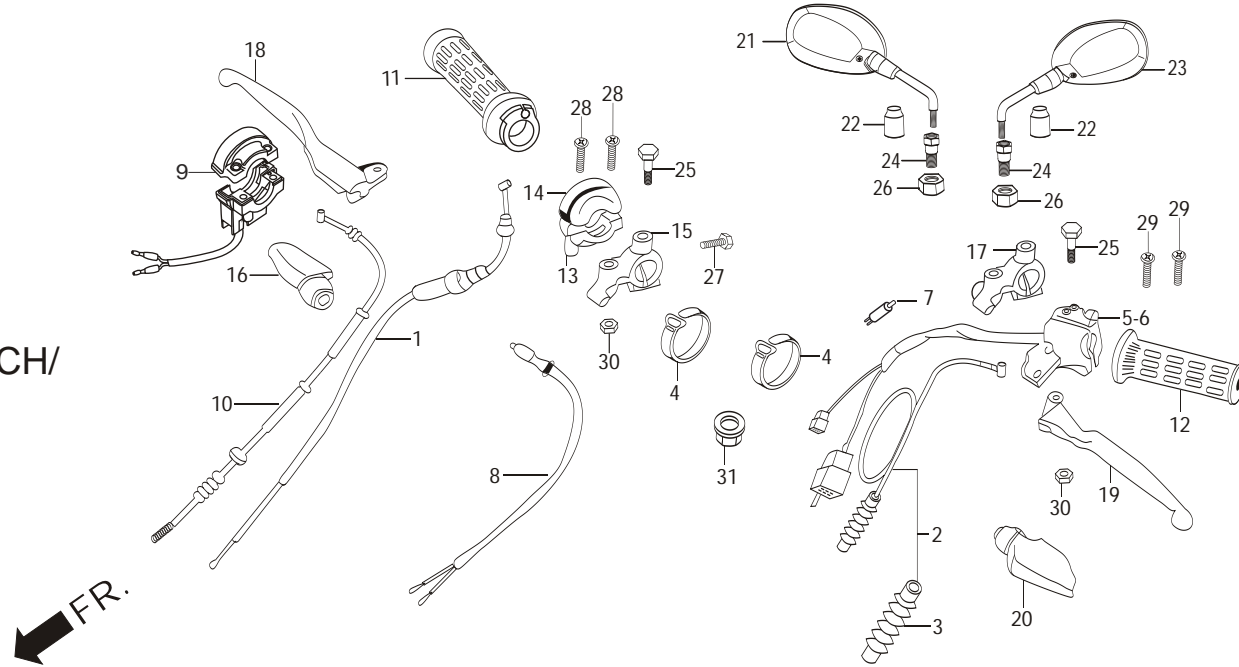

Service Item	F.R.T.	Ref. No.	Part No.	Description	Reqd. No.			
					SPLENDOR PRO			
					DRUM			
					KICK		SELF	
		SPOKE	CAST	SPOKE	CAST			
*CABLE COMP., THROTTLE.....	0.3	1	17910-KWH-970	CABLE COMP., THROTTLE	1	1	1	1
*CABLE COMP., CLUTCH.....	0.2	2	22870-KWH-970	CABLE COMP., CLUTCH.....	1	1	1	1
*SWITCH ASSY., WINKER	0.5	3	22871-116-670	BOOT, CLUTCH CABLE	1	1	1	1
*SWITCH ASSY., FR. STOP		4	32161-404-000	BAND B-1, WIRE	2	2	2	2
*CABLE COMP., FR. BRAKE.....		5	35200-KWH-960	SWITCH ASSY., WINKER.....	1	1	-	-
*GRIP COMP., 'R'	0.6							
*GRIP 'L' HANDLE	0.6	6	35200-KWH-970	SWITCH ASSY., WINKER.....	-	-	1	1
*HOUSING UPPER, THROTTLE.....		7	35330-413-000	SWITCH COMP., FR. LEVER	1	1	1	1
*HOUSING UNDER, THROTTLE		8	35340-KST-950	SWITCH ASSY., FR. STOP.....	1	1	1	1
*BRACKET 'R' HANDLE LEVER		9	35150-KWA-841	SWITCH ASSY., START	-	-	1	1
*BRACKET 'L' HANDLE LEVER		10	45450-KCC-710	CABLE COMP., FR. BRAKE	1	1	1	1
*COVER 'R' HANDLE LEVER.....								
*COVER 'L' HANDLE LEVER								
		11	53140-KCC-900	GRIP COMP., R.....	1	1	1	1
		12	53166-KY0-750	GRIP L. HANDLE	1	1	1	1
		13	53167-GE4-000	HOUSING UNDER, THROTTLE	1	1	1	1
		14	53168-166-000	HOUSING UPPER, THROTTLE	1	1	1	1
		15	53171-198-900	BRACKET R. HANDLE LEVER	1	1	1	1
		16	53171-KCC-900	COVER R. HANDLE LEVER.....	1	1	1	1
		17	53172-KTC-920	BRACKET L. HANDLE LEVER	1	1	1	1
		18	53175-KVH-850	LEVER COMP., R. STEERING HANDLE.....	1	1	1	1
		19	53178-KVH-850	LEVER COMP., L. STEERING HANDLE	1	1	1	1
		20	53179-KTC-900	COVER L. HANDLE LEVER	1	1	1	1

F - 3
HANDLE LEVER/SWITCH/
CONTROL CABLE

FR.

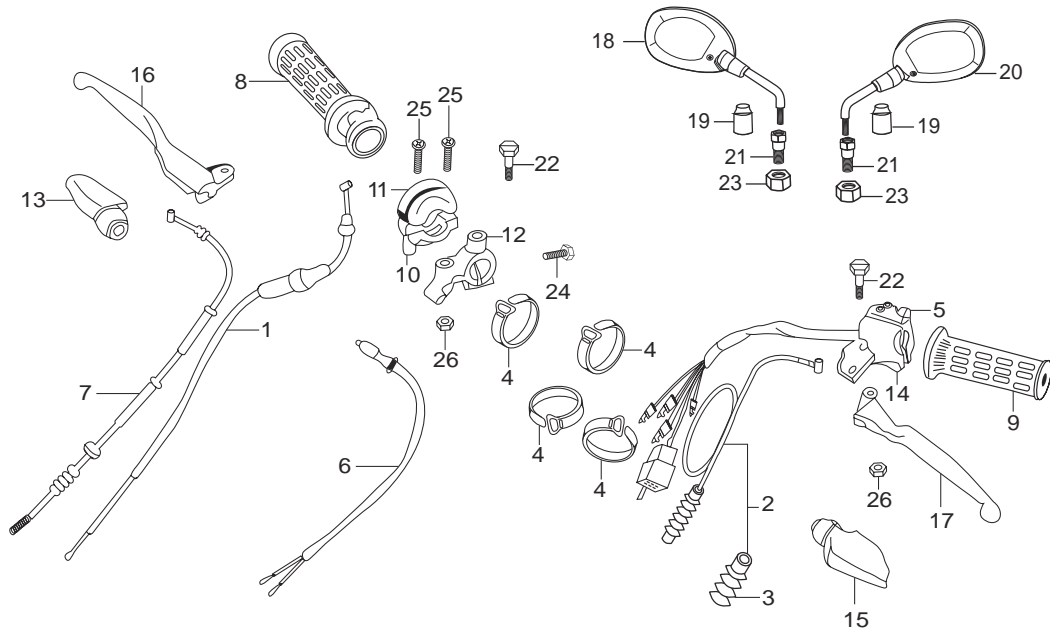

Service Item	F.R.T.	Ref. Part No.	Description	Reqd. No. SPLENDOR PRO			
				DRUM			
				KICK		SELF	
				SPOKE	CAST	SPOKE	CAST
* CABLE COMP, THROTTLE	0.3	21	88110-AAC-H41ZA MIRROR ASSY.,'R'BACK (BLACK-1)	1	1	1	1
* CABLE COMP, CLUTCH	0.2		88110-AAC-H41ZB MIRROR ASSY.,'R'BACK (BLACK-2)	1	1	1	1
* SWITCH ASSY, WINKER	0.5		88110-AAC-H41ZC MIRROR ASSY.,'R'BACK (CLOUD SILVER ME.)	1	1	1	1
* SWITCH ASSY, FR. STOP			88110-AAC-H41ZD MIRROR ASSY.,'R'BACK (CANDY BLAZING RED)	1	1	1	1
* CABLE COMP, FR. BRAKE			88110-AAC-H41ZE MIRROR ASSY.,'R'BACK (EXCELLENT BLUE ME.)	1	1	1	1
* GRIP COMP, ÔRÔ HANDLE	0.6		88110-AAC-H41ZF MIRROR ASSY.,'R'BACK (HI-GRANITE BLUE ME.)	1	1	1	1
* GRIP ÔLÔ HANDLE	0.6		88110-AAC-H41ZG MIRROR ASSY.,'R'BACK (PALACE MAROON ME.)	1	1	1	1
* HOUSING UPPER, THROTTLE			88110-AAC-H41ZH MIRROR ASSY.,'R'BACK (HEAVY GRAY ME.)...	1	1	1	1
* HOUSING UNDER, THROTTLE		22	88114-198-D10 CAP LOCK NUT,.....	2	2	2	2
* BRACKET ÔRÔ HANDLE LEVER		23	88120-AAC-H41ZA MIRROR ASSY.,'L'BACK (BLACK-1)	1	1	1	1
* BRACKET ÔLÔ HANDLE LEVER			88120-AAC-H41ZB MIRROR ASSY.,'L'BACK (BLACK-2)	1	1	1	1
* COVER ÔRÔ HANDLE LEVER			88120-AAC-H41ZC MIRROR ASSY.,'L'BACK (CLOUD SILVER ME.)	1	1	1	1
* COVER ÔLÔ HANDLE LEVER			88120-AAC-H41ZD MIRROR ASSY.,'L'BACK (CANDY BLAZING RED)	1	1	1	1
			88120-AAC-H41ZE MIRROR ASSY.,'L'BACK (EXCELLENT BLUE ME.)	1	1	1	1
			88120-AAC-H41ZF MIRROR ASSY.,'L'BACK (HI-GRANITE BLUE ME.)	1	1	1	1
			88120-AAC-H41ZG MIRROR ASSY.,'L'BACK (PALACE MAROON ME.)	1	1	1	1
			88120-AAC-H41ZH MIRROR ASSY.,'L'BACK (HEAVY GRAY ME.)....	1	1	1	1
		24	90003-KCC-840 BOLT, ADPT. 10MM	2	2	2	2
		25	90114-310-000 BOLT, HANDLE LEVER PIVOT	2	1	1	1
		26	90201-MW3-620 NUT, HEX, 10 MM	2	2	2	2
		27	92000-06025-OA BOLT, HEX., 6X25	1	2	2	2

F - 3
**HANDLE LEVER/SWITCH/
 CONTROL CABLE**

FR.

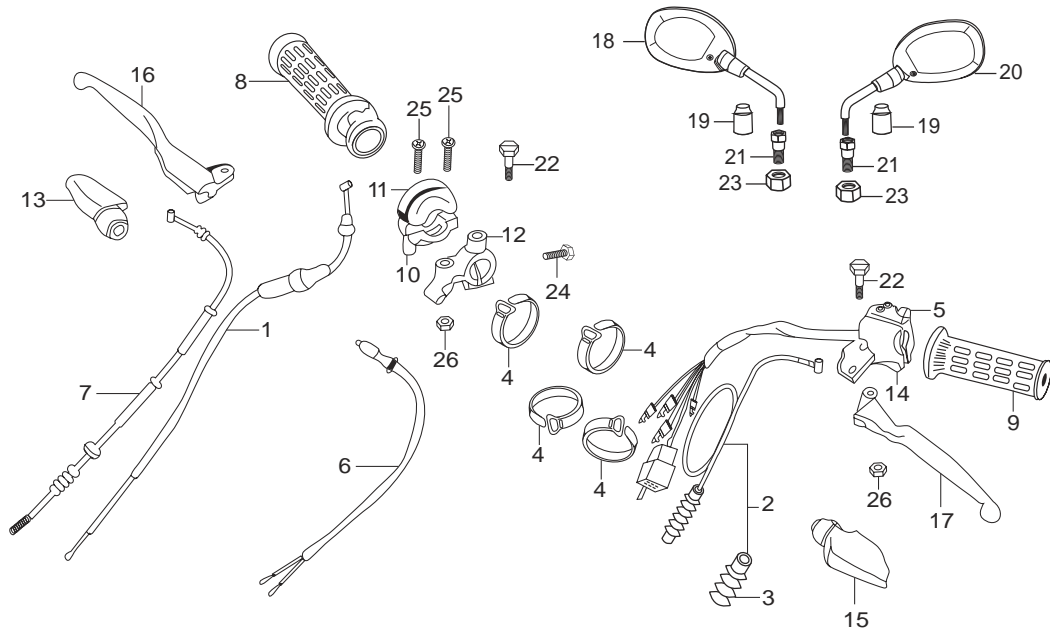

Service Item	F.R.T.	Ref. Part No. No.	Description	Reqd. No. SPLENDOR PRO			
				DRUM			
				KICK		SELF	
				SPOKE	CAST	SPOKE	CAST
* CABLE COMP, THROTTLE	0.3	28 93500-05022-1G	SCREW, PAN 5 X 22	2	2	2	2
* CABLE COMP, CLUTCH	0.2	29 94001-06000-OS	NUT, HEX., 6 MM	2	2	2	2
* SWITCH ASSY, WINKER	0.5						
* SWITCH ASSY, FR. STOP							
* CABLE COMP, FR. BRAKE							
* GRIP COMP, ÔRÔ HANDLE	0.6						
* GRIP ÔLÔ HANDLE	0.6						
* HOUSING UPPER, THROTTLE							
* HOUSING UNDER, THROTTLE							
* BRACKET ÔRÔ HANDLE LEVER							
* BRACKET ÔLÔ HANDLE LEVER							
* COVER ÔRÔ HANDLE LEVER							
* COVER ÔLÔ HANDLE LEVER							

F - 4
HANDLE PIPE/TOP BRIDGE

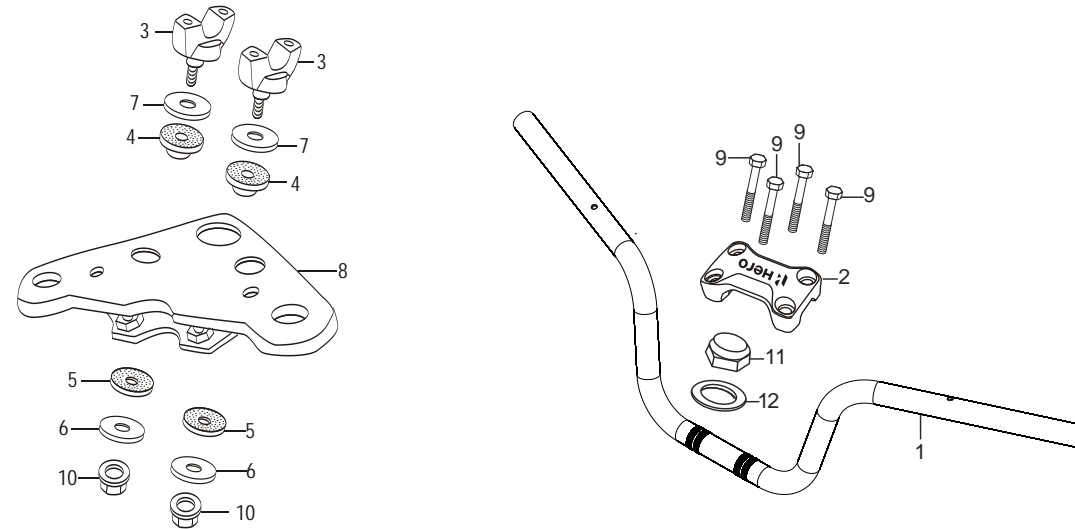

FR.

Service Item	F.R.T.	Ref. No.	Part No.	Description	Reqd. No. SPLENDOR PRO			
					DRUM			
					KICK		SELF	
SPOKE	CAST	SPOKE	CAST					
*PIPE, STEERING HANDLE.....	0.5	1	53100-KWH-970	PIPE, STEERING HANDLE.....	1	1	1	1
*BRIDGE COMP., FORK TOP		2	53131-AAF-H00	HOLDER HANDLE UP	1	1	1	1
*HOLDER, HANDLE PIPE UNDER	0.2	3	53132-124-000	HOLDER, HANDLE PIPE UNDER	2	2	2	2
.....		4	53133-198-900	RUBBER, HANDLE CUSHION UPPPER.....	2	2	2	2
(ADD 0.1 FOR EACH)		5	53134-028-000	RUBBER, HANDLE CUSHION UNDER	2	2	2	2
		6	53135-198-900	WASHER, HANDLE CUSHION.....	2	2	2	2
		7	53136-198-900	PLATE, HANDLE CUSHION	2	2	2	2
		8	53230-KWH-960	BRIDGE COMP., FORK TOP	1	1	1	1
		9	90023-KL8-730	BOLT SPL. 6X28	1	1	1	1
		10	90304-KTE-911	NUT FLANGE. PT. 10 MM.....	2	2	2	2
		11	90304-KSP-900	NUT STEERING STEM.....	1	1	1	1
		12	90503-KTR-900	WASHER, STEERING STEM NUT	1	1	1	1

F-5 STEERING STEM/HORN

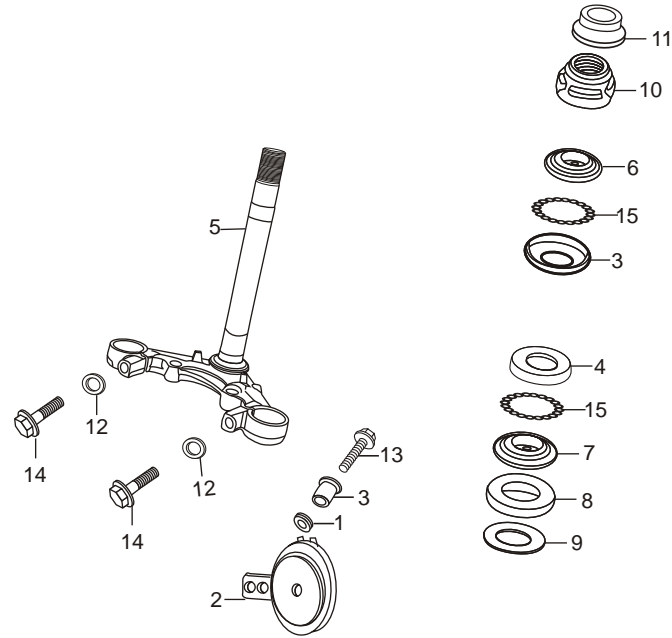

Service Item	F.R.T.	Ref. No.	Part No.	Description	Reqd. No. SPLENDOR PRO			
					DRUM			
					KICK		SELF	
					SPOKE	CAST	SPOKE	CAST
* PIPE, STEERING HANDLE	0.5	1	33714-KL3-620	RUBBER, TAIL LIGHT BRACKET	2	2	2	2
* BRIDGE COMP, FORK TOP		2	38110-KTR-A01	HORN COMP.,	1	1	1	1
* HOLDER, HANDLE PIPE UNDER	0.2	3	38117-KFE-701	COLLAR, HORN SET	1	1	1	1
(ADD 0.1 FOR EACH)		4	50301-KTR-900	RACE, (STRG.TOP) BALL	2	2	2	2
		5	53200-KST-950	STEM, COMP. STEERING	1	1	1	1
		6	53211-268-010	RACE, (STRG.TOP) CONE	1	1	1	1
		7	53212-200-000	RACE, (STRG.BOTTOM) CONE	1	1	1	1
		8	53214-200-000	DUST, SEAL, STRG.HEAD	1	1	1	1
		9	53215-KTR-900	BALL ASSY., STEERING	2	2	2	2
		10	53221-KTR-900	THREAD, STRG.TOP	1	1	1	1
		11	53222-KTR-900	MUD GUARD, STRG.(HEAD TOP)	1	1	1	1
		12	94101-08000	WASHER, PLAIN 8 MM	1	1	1	1
		13	95701-06020-07	BOLT, FLANGE 6X20	1	1	1	1
		14	95701-08040-00	BOLT, FLANGE 8X40	2	2	2	2
		15	96211-08000	BALL, STEEL 8 MM	32	32	32	32

F - 6 FRONT FENDER

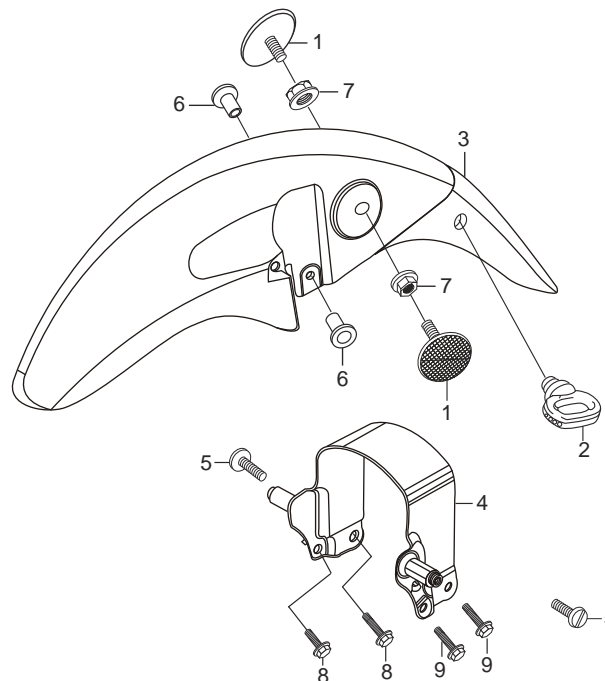

Service Item	F.R.T.	Ref. No.	Part No.	Description	Reqd. No. SPLENDOR PRO			
					DRUM			
					KICK		SELF	
					SPOKE	CAST	SPOKE	CAST
* FENDER, FRONT	0.2	1	33741-KST-920	REFLEX, LEFT FRONT	2	2	2	2
		2	45451-KCC-900	GUIDE FRONT (FENDER) CABLE	1	1	1	1
		3	61100-KST-940ZA	SET, FR. FENDER(BLACK-1).....	1	1	1	1
			61100-KST-940ZB	SET, FR. FENDER(BLACK-2).....	1	1	1	1
			61100-KWH-970ZC	SET, FR. FENDER(CLOUD SILVER ME.)	1	1	1	1
			61100-KST-940ZD	SET, FR. FENDER(CANDY BLAZING RED)	1	1	1	1
			61100-KWH-970ZE	SET, FR. FENDER(EXCELLENT BLUE ME.)	1	1	1	1
			61100-KWH-970ZF	SET, FR. FENDER (HI-GRANITE BLUE ME.)	1	1	1	1
			61100-KWH-970ZG	SET, FR. FENDER(PALACE MAROON ME.)	1	1	1	1
			61100-KWH-970ZH	SET, FR. FENDER (HEAVY GRAY ME.).....	1	1	1	1
		4	61102-KST-940	PLATE FRONT FENDER	1	1	1	1
		5	90104-KCC-870	BOLT, SPECIAL 6X12	2	2	2	2
		6	90501-KCC-870	COLLAR FR., FENDER SET.....	2	2	2	2
		7	94050-06000	NUT, FLANGE 6 MM	2	2	2	2
		8	95701-06012-08	BOLT, FLANGE 6X12.....	2	2	2	2
		9	95701-06020-00	BOLT, FLANGE 6X20	2	2	2	2

F - 7 FRONT FORK

FR.

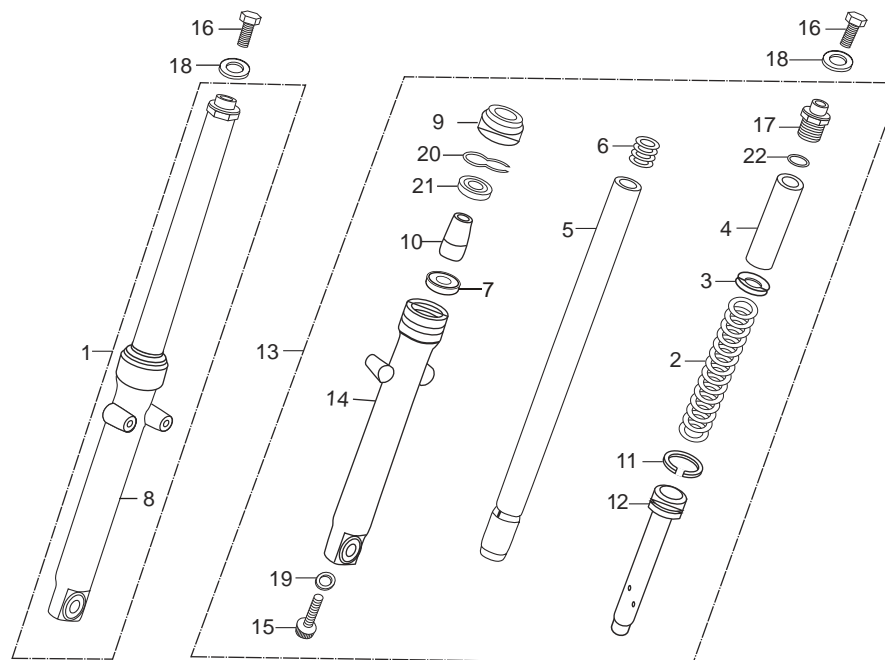

Service Item	F.R.T.	Ref. No.	Part No.	Description	Reqd. No. SPLENDOR PRO			
					DRUM			
					KICK		SELF	
					SPOKE	CAST	SPOKE	CAST
* FORK ASSY, FR	0.5	1	51400-KST-A11	FORK ASSY., R FRONT	1	1	1	1
(ADD 0.2 FOR EACH)		2	51401-KST-941	SPRING, FRONT FORK	2	2	2	2
* SPRING, FR. CUSHION		3	51403-447-730	JOINT. SPRING	2	2	2	2
(ADD 0.2 FOR EACH)		4	51403-KCC-900	COLLAR. SPRING	2	2	2	2
* PIPE COMP, FR. FORK	0.8	5	51410-KWA-941	PIPE COMP., FR FORK	2	2	2	2
(ADD 0.5 FOR EACH)		6	51412-KAG-900	SPRING REBOUND	2	2	2	2
* CASE FR. BOTTOM	0.9	7	51412-KWA-941	RING, BACK UP	2	2	2	2
(ADD 0.5 FOR EACH)		8	51420-KST-A11	CASE COMP, R, FRONT BOTTOM	1	1	1	1
		9	51425-KST-901	SEAL DUST	2	2	2	2
		10	51432-KST-901	PIECE OIL LOCK	2	2	2	2
		11	51437-KVN-901	RING, PISTON	2	2	2	2
		12	51440-KTR-901	PIPE SEAT	2	2	2	2
		13	51500-KST-A11	FORK ASSY. L FRONT	1	1	1	1
		14	51520-KST-A11	CASE COMP., L. FRONT BOTTOM	-	-	-	-
		15	90116-KAG-900	BOLT SOCKET 8 MM	2	2	2	2
		16	90123-KRM-860	BOLT, FRONT FORK	1	1	1	1
		17	90123-KST-941	BOLT, 'A' FRONT FORK	2	2	2	2
		18	90521-292-000	WASHER, PLAIN 10.3 MM	1	1	1	1
		19	90544-439-930	WASHER, SPECIAL 8 MM	2	2	2	2
		20	90601-GF5-730	RING, OIL SEAL STOPPER	2	2	2	2

F - 7 FRONT FORK

FR.

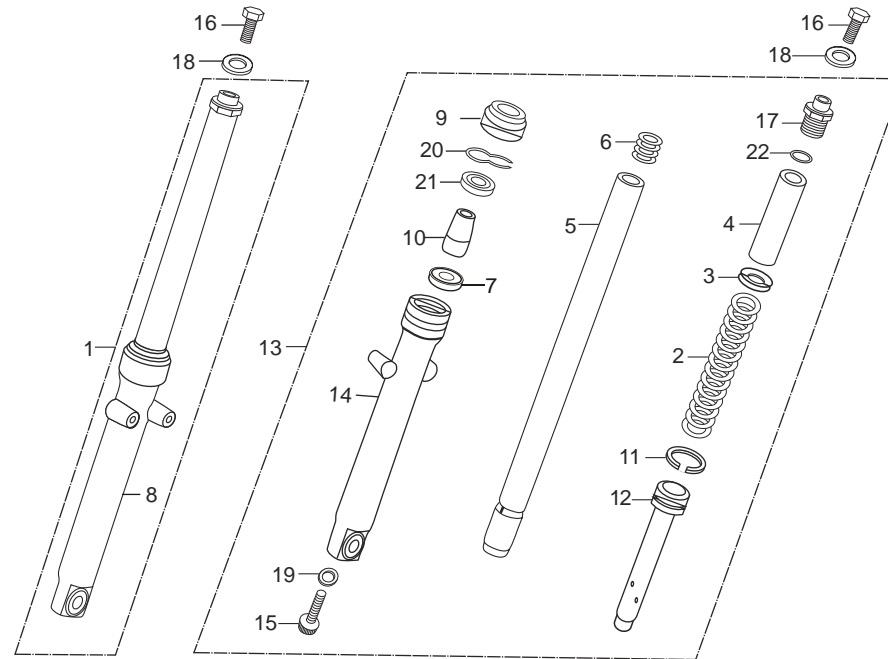

Service Item	F.R.T.	Ref. No.	Part No.	Description	Reqd. No. SPLENDOR PRO			
					DRUM			
					KICK		SELF	
		SPOKE	CAST	SPOKE	CAST			
* FORK ASSY, FR.....	0.5	21	91255-KWA-941	SEAL, OIL,30X42X11.....	2	2	2	2
(ADD 0.2 FOR EACH)		22	91356-KAG-900	O-RING	2	2	2	2
* SPRING, FR. CUSHION								
(ADD 0.2 FOR EACH)								
* PIPE COMP, FR. FORK	0.8							
(ADD 0.5 FOR EACH)								
* CASE FR. BOTTOM	0.9							
(ADD 0.5 FOR EACH)								

F - 8 FRONT BRAKE PANEL

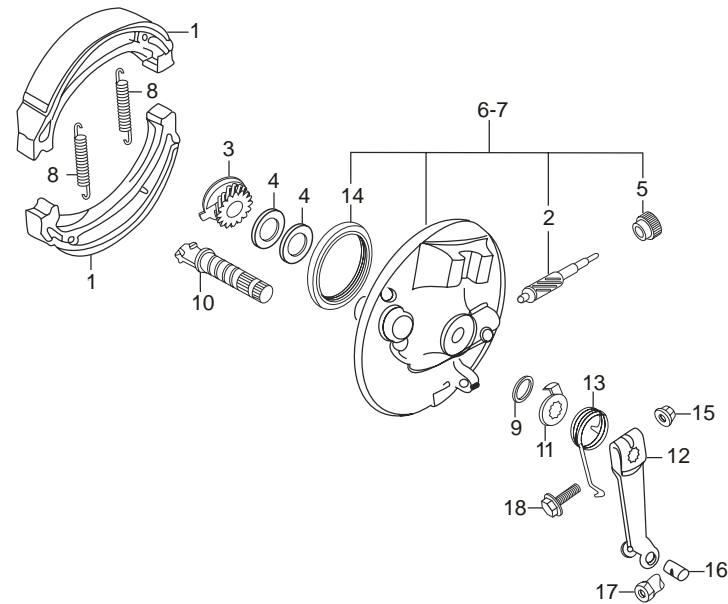

Service Item	F.R.T.	Ref. No.	Part No.	Description	Reqd. No. SPLENDOR PRO			
					DRUM			
					KICK		SELF	
					SPOKE	CAST	SPOKE	CAST
* GEAR, SPEEDOMETER	0.3	1	43125-KRP-981	SHOE COMP., BRAKE	2	2	2	2
* PINION, SPEEDOMETER	0.6		43125-KTN-701	SHOE COMP., BRAKE	(2)	(2)	(2)	(2)
* PANEL SUB COMP, FR. BRAKE	0.4	2	44805-KTC-900	PINION, SPEEDOMETER	1	1	1	1
(INC. RELATIVE PART)		3	44806-KST-900	GEAR, SPEEDOMETER	1	1	1	1
* SHOE COMP, BRAKE		4	44809-170-000	WASHER, SPEEDOMETER GEAR	2	2	2	2
(ONE OR ALL)		5	44810-KTC-900	BUSH, PINION	1	1	1	1
* ARM. FR. BRAKE	0.1	6	45010-KTR-700	PANEL SUB. COMP, FR. BRAKE (MGM).....	-	1	-	1
(INC. RELATIVE PART)		7	45010-KTC-900	PANEL SUB. COMP. FR. BRAKE (CSM)	1	-	1	-
		8	45133-KCC-900	SPRING FRONT, BRAKE SHOE.....	2	2	2	2
		9	45134-250-000	BRAKE, CAM DUST SEAL	1	1	1	1
		10	45141-KTC-900	CAM FRONT BRAKE.....	1	1	1	1
		11	45145-096-650	INDICATOR FR., BRAKE.....	1	1	1	1
		12	45410-KCC-900	ARM FRONT BRAKE.....	1	1	1	1
		13	45435-GB2-720	SPRING, BRAKE ARM RETURN	1	1	1	1
		14	91251-GK4-000	OIL, SEAL 47X60X7	1	1	1	1
		15	94050-06000	NUT, FLANGE 6 MM.....	1	1	1	1
		16	95015-32001	JOINT, B. BRAKE ARM.....	1	1	1	1
		17	95015-42000	NUT, 'B' ADJUST	1	1	1	1
		18	95701-06032-00	BOLT, FLANGE 6X32.....	1	1	1	1

**F - 9
FRONT WHEEL**

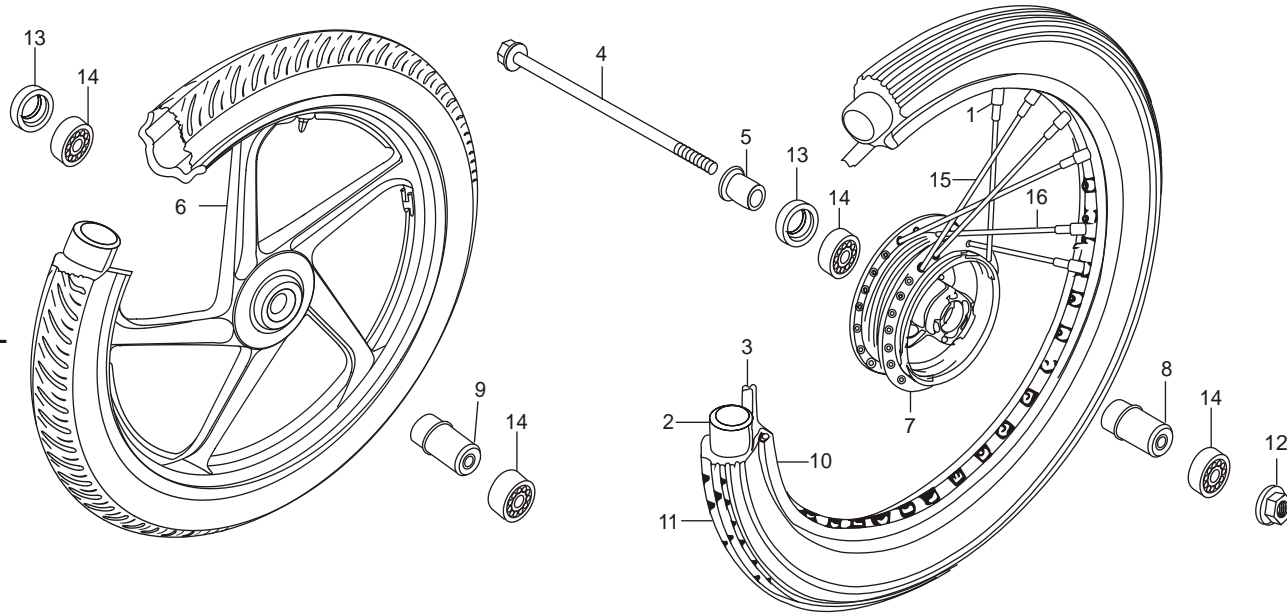

Service Item	F.R.T.	Ref. No.	Part No.	Description	Reqd. No. SPLENDOR PRO			
					DRUM			
					KICK		SELF	
					SPOKE	CAST	SPOKE	CAST
*TUBE, TYRE.....	0.9	1	42603-198-900	NIPPLE SPOKE-9.....	36	-	36	-
*TYRE, FR. (2.75 X 18-4 PR)		2	42712-KCS-920	TUBE TYRE (2.75X18)	1	1	1	1
*AXLE, FR. WHEEL	0.2	3	42713-KFN-850	FLAP TYRE (1.40 X 18)	1	-	1	1
*HUB, FR. WHEEL.....	2.5	4	44301-KTR-700	AXLE FR. WHEEL	1	1	1	1
*COLLAR, FR. AXLE DISTANCE.....	0.4	5	44311-KRC-900	COLLAR FR. WHEEL SIDE	1	1	1	1
*BEARING RADIAL BALL, 6301U		6	44601-AAE-H20	WHEEL COMP. FR.	-	1	-	1
(ADD 0.1 FOR EACH)		7	44601-KTR-940	HUB COMP. FR WHEEL.....	1	-	1	-
*RIM, FR. WHEEL.....	2.2	8	44620-198-900	COLLAR FR. AXLE DISTANCE	1	-	1	-
*OIL SEAL, 21 X 37 X 7	0.3	9	44620-400-000	COLLAR FR. AXLE DISTANCE	-	1	1	1
		10	44701-AAC-H00	RIM FR. WHEEL (1.6X18)	1	-	1	-
		11	44711-KFN-850R	TYRE, FR. (2.75-18-42P).....	1	1	1	1
		12	90306-KST-942	NUT, FLGMPT, 12 MM.....	1	1	1	1
		13	90755-229-000	OIL SEAL 21X37X7.....	1	1	1	1
		14	96140-63010-10	BEARING BALL RADIAL 6301	2	2	2	2
		15	97252-51162-10	SPOKE A9X161	18	-	18	-
		16	97603-51162-10	SPOKE A9X161	18	-	18	-

F - 10 REAR BRAKE PANEL

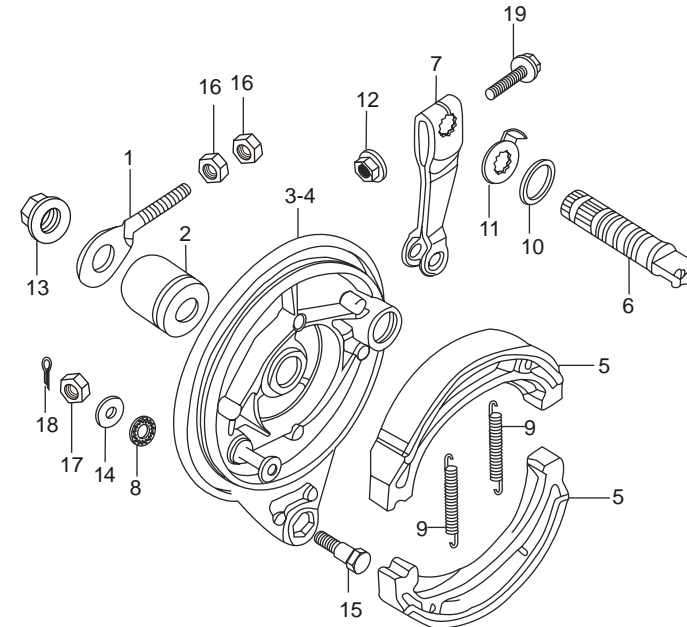

Service Item	F.R.T.	Ref. No.	Part No.	Description	Reqd. No. SPLENDOR PRO			
					DRUM			
					KICK		SELF	
					SPOKE	CAST	SPOKE	CAST
* PANEL COMP, RR. BRAKE	0.5	1	40543-198-900	ADJUSTER, CHAIN R	1	1	1	1
* SHOE COMP, BRAKE	0.4	2	42313-198-900	COLLAR, RR. BRAKE PANEL SIDE	1	1	1	1
(ONE OR ALL)		3	43100-153-6012	PANEL, COMP. RR BRAKE (MGM)	-	1	-	1
* ARM, RR. BRAKE	0.1	4	43100-153-600	PANEL, COMP RR BRAKE (ISM)	1	-	1	-
(INC. RELATIVE PART)		5	43125-KRP-981	SHOE, COMP.BRAKE	2	2	2	2
		6	43141-KST-920	CAM, REAR BRAKE	1	1	1	1
		7	43410-KST-940	ARM, REAR BRAKE	1	1	1	1
		8	43434-286-000	RUBBER, STOPPER ARM CUSHION	1	1	1	1
		9	45133-KCC-900	SPRING FR., BRAKE SHOE	2	2	2	2
		10	45134-250-000	BRAKE, CAM DUST SEAL	1	1	1	1
		11	45145-096-650	INDICATOR FRONT BRAKE	1	1	1	1
		12	90302-KST-942	NUT FLANGE PT 6 MM	1	1	1	1
		13	90306-KST-942	NUT FLANGE PT. 12 MM	1	1	1	1
		14	90505-425-000	WASHER, 8 MM	1	1	1	1
		15	92811-10000	BOLT, 'A' BRAKE STOPPER	1	1	1	1
		16	94001-06000-0S	NUT HEX., 6 MM	2	2	2	2
		17	94001-08000-0S	NUT HEX., 8MM	1	1	1	1
		18	94201-20150	PIN, SPLIT 2X15 MM	1	1	1	1
		19	95701-06035-00	BOLT, FLANGE 6X35	1	1	1	1

**F - 11
REAR WHEEL**

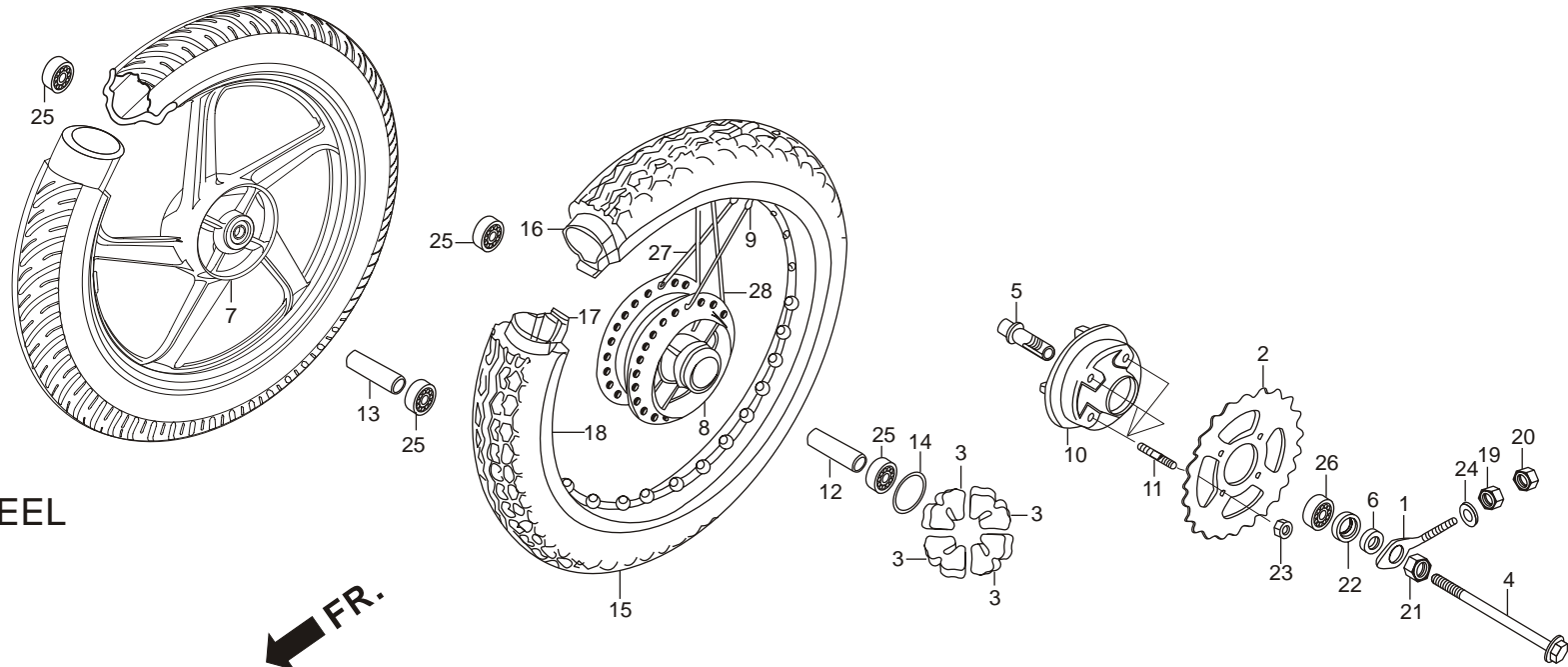

Service Item	F.R.T.	Ref. No.	Part No.	Description	Reqd. No. SPLENDOR PRO			
					DRUM			
					KICK		SELF	
					SPOKE	CAST	SPOKE	CAST
* AXLE, RR. WHEEL.....	0.2	1	40544-198-900	ADJUSTER, 'L' CHAIN	1	1	1	1
* SPROCKET, FINAL DRIVEN	0.7	2	41201-KVH-760	SPROCKET, FINAL DRIVEN (44T).....	1	1	1	1
* DAMPER, RR. WHEEL	0.4	3	41241-KST-941	DAMPER, RR. WHEEL	4	4	4	4
(ONE OR ALL)		4	42301-KST-940	AXLE, RR. WHEEL	1	1	1	1
* COLLAR, RR. AXLE DISTANCE		5	42303-KST-940	SLEEVE, RR. WHEEL	1	1	1	1
* BEARING, RADIAL BALL, 6301 (ADD 0.1 FOR EACH)		6	42304-198-900	COLLAR, RR. AXLE SLEEVE	1	1	1	1
* SLEEVE, RR. WHEEL	0.5	7	42601-AAE-H20	WHEEL COMP. REAR	-	1	-	1
* HUB, RR. WHEEL	2.5	8	42601-KTR-940	HUB COMP. REAR WHEEL.....	1	-	1	-
* FLANGE, FINAL DRIVEN.....	0.8	9	42603-198-900	NIPPLE, SPOKE-9	36	-	36	-
* TYRE, RR (2.75-18-6PR).....	0.9	10	42611-KST-940	FLANGE, FINAL, DRIVEN	1	1	1	1
* RIM, WHEEL (1.60 X 18).....	2.3	11	42615-198-900	BOLT, STUD., 8 X 35.5	4	4	4	4
* BEARING, RADIAL BALL, 6203.....	0.6	12	42620-198-900	COLLAR, RR. AXLE DISTANCE	-	1	1	1
		13	42620-GB6-920	COLLAR, RR. AXLE DISTANCE	1	-	1	1
		14	42653-001-000	O-RING, 40.5 X 3	1	1	1	1
		15	42711-KTC-901	TYRE, RR. (3.0 X 18).....	1	1	1	1
		16	42712-KCS-920	TUBE, TYRE (2.5 -X 18)	1	1	1	1
		17	42713-KFN-850	FLAP, TYRE (1.40 X 18).....	1	-	1	-
		18	44701-AAC-H50	RIM, WHEEL (1.60 X 18)	1	-	1	-
		19	90302-KBP-900	NUT, SPL 6MM.....	1	1	1	1
		20	90306-KST-942	NUT, FLGMPT, 12 MM	1	1	1	1

**F - 11
REAR WHEEL**

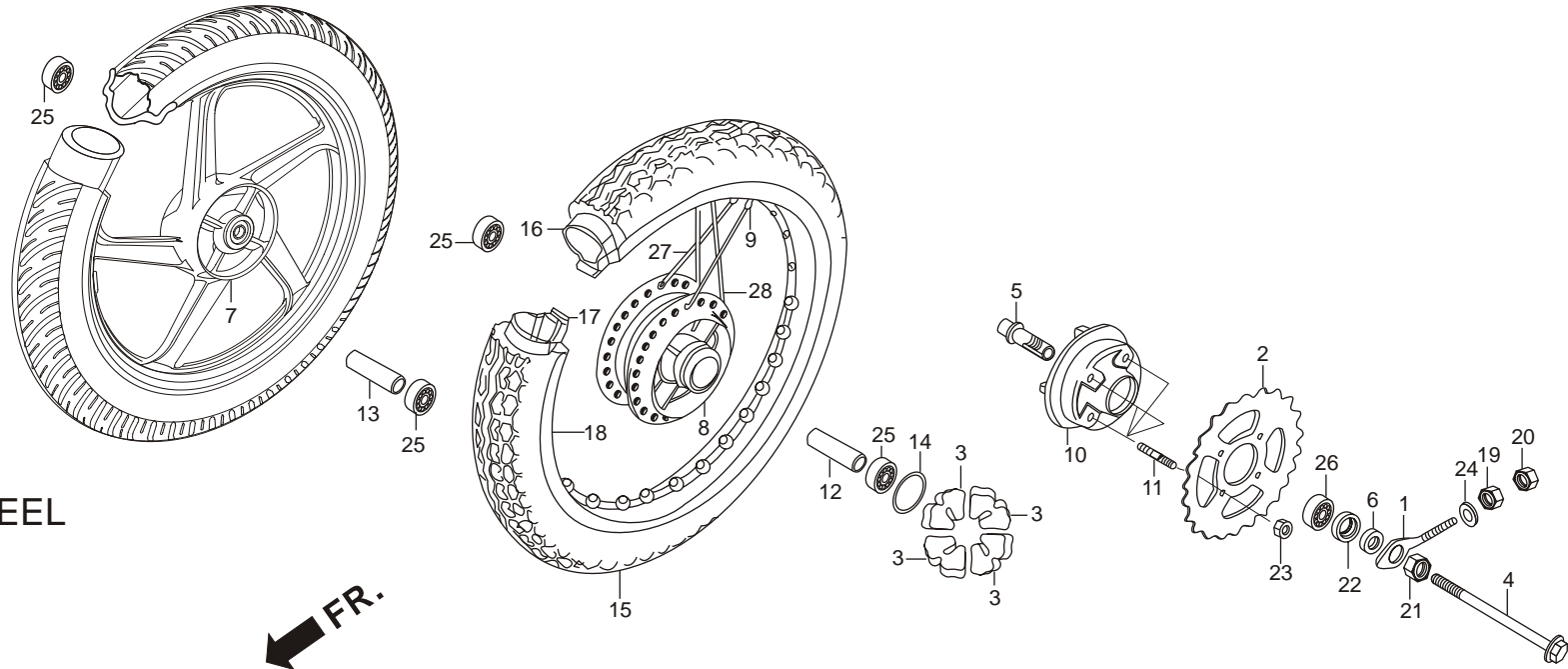

Service Item	F.R.T.	Ref. No.	Part No.	Description	Reqd. No. SPLENDOR PRO			
					DRUM			
					KICK		SELF	
					SPOKE	CAST	SPOKE	CAST
* AXLE, RR. WHEEL.....	0.2	21	90307-001-000	NUT, RR. AXLE SLEEVE	1	1	1	1
* SPROCKET, FINAL DRIVEN	0.7	22	90753-029-000	OIL SEAL, 27 X 40 X 6.....	1	1	1	1
* DAMPER, RR. WHEEL	0.4	23	94001-06000-0S	NUT, HEX., 6 MM	1	1	1	1
(ONE OR ALL)		24	94101-06000	WASHER PLAIN 6MM	1	1	1	1
* COLLAR, RR. AXLE DISTANCE		25	96140-63010-10	BEARING, RADIAL BALL, 6301.....	2	2	2	2
* BEARING, RADIAL BALL, 6301 (ADD 0.1 FOR EACH)		26	96150-62030-10	BEARING, RADIAL BALL, 6203(UU).....	1	1	1	1
* SLEEVE, RR. WHEEL.....	0.5	27	97338-51179-10	SPOKE, (A9X169.5).....	18	-	18	-
* HUB, RR. WHEEL	2.5	28	97604-51178-10	SPOKE, (A9X169).....	18	-	18	-
* FLANGE, FINAL DRIVEN.....	0.8							
* TYRE, RR (2.75-18-6PR).....	0.9							
* RIM, WHEEL (1.60 X 18).....	2.3							
* BEARING, RADIAL BALL, 6203.....	0.6							

F - 12
SET ASSY./RR. COWL/
REAR CARRIER

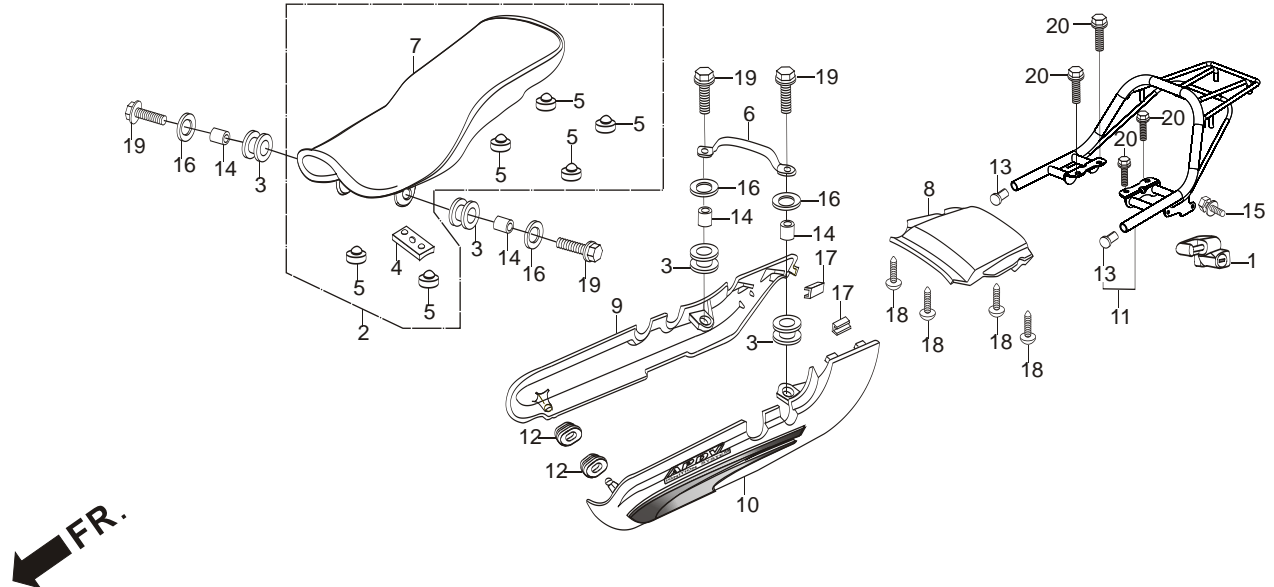

Service Item	F.R.T.	Ref. Part No. No.	Description	Reqd. No. SPLENDOR PRO			
				DRUM			
				KICK		SELF	
				SPOKE	CAST	SPOKE	CAST
*SEAT ASSY., DOUBLE	0.1	1 50720-AAD-H00	HOLDER ASSY., HELMET	1	1	1	1
*SET, CENTER RR. COWL		2 77200-KCC-900	SEAT ASSY., DOUBLE	1	1	1	1
*SET, RIGHT SIDE COWL		3 77202-KCC-900	RUBBER, SEAT MOUNTING	4	4	4	4
*SET, LEFT SIDE COWL		4 77204-KCC-900	RUBBER 'A' SEAT SETTING	1	1	1	1
*CARRIER REAR		5 77206-KCC-900	RUBBER, SEAT CUSHION	6	6	6	6
		6 77215-KCC-900	CROSS PIPE	1	1	1	1
		7 77230-KCC-900	COVER, SEAT ASSY	1	1	1	1
		8 77235-AAD-H70ZA	SET,CENTER RR. COWL BLACK.....	1	1	1	1
		77235-AAD-H70ZC	SET,CENTER RR. COWL (CLOUD SILVER ME.)	1	1	1	1
		77235-AAD-H70ZD	SET,CENTER RR. COWL (CANDY BLAZING RED)	1	1	1	1
		77235-AAD-H70ZE	SET,CENTER RR. COWL (EXCELLENT BLUE ME.)	1	1	1	1
		77235-AAD-H70ZF	SET,CENTER RR. COWL (HI-GRANITE BLUE ME.)	1	1	1	1
		77235-AAD-H70ZG	SET,CENTER RR. COWL (PALACE MAROON ME.)	1	1	1	1
		77235-AAD-H70ZH	SET,CENTER RR. COWL (HEAVY GRAY ME.)	1	1	1	1
		9 77300-AAD-H70ZA	SET,R'SIDE COWL (BLACK-1).....	1	1	1	1
		77300-AAD-H70ZB	SET,R'SIDE COWL (BLACK-2).....	1	1	1	1
		77300-AAD-H70ZC	SET,R'SIDE COWL (CLOUD SILVER ME.)	1	1	1	1
		77300-AAD-H70ZD	SET,R'SIDE COWL (CANDY BLAZING RED)	1	1	1	1
		77300-AAD-H70ZE	SET,R'SIDE COWL (EXCELLENT BLUE ME.)	1	1	1	1
		77300-AAD-H70ZF	SET,R'SIDE COWL (HI-GRANITE BLUE ME.)	1	1	1	1

F - 12
SET ASSY./RR. COWL/
REAR CARRIER

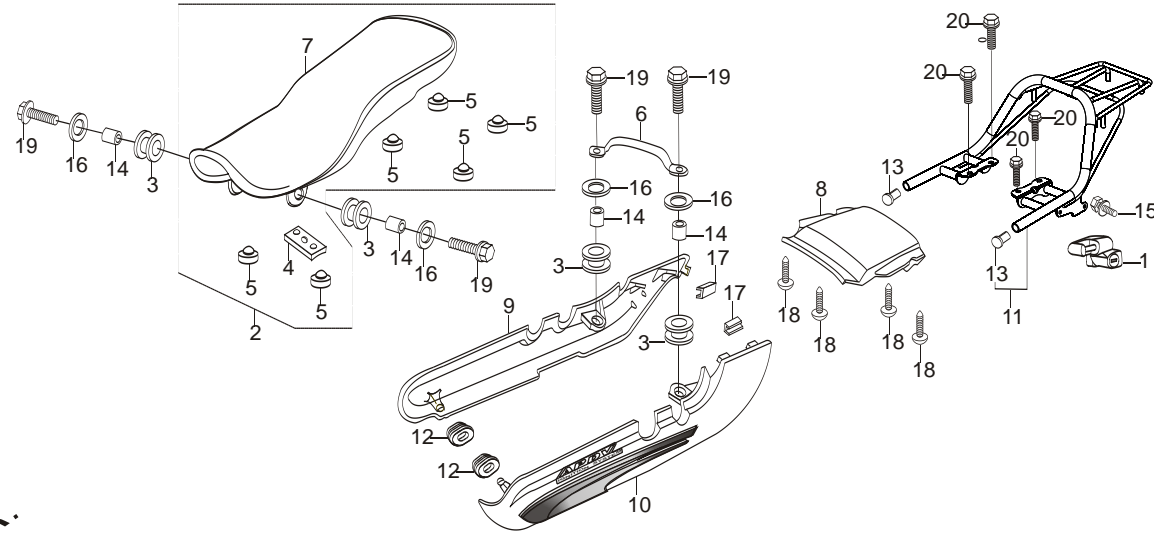

Service Item	F.R.T.	Ref. No.	Part No.	Description	Reqd. No. SPLENDOR PRO			
					DRUM			
					KICK		SELF	
					SPOKE	CAST	SPOKE	CAST
*SEAT ASSY., DOUBLE	0.1	9	77300-AAD-H70ZG	SET, 'R'SIDE COWL (PALACE MAROON ME.) ...	1	1	1	1
*SET, CENTER RR. COWL			77300-AAD-H70ZH	SET, 'R' SIDE COWL (HEAVY GRAY ME.).....	1	1	1	1
*SET, RIGHT SIDE COWL.....								
*SET, LEFT SIDE COWL		10	77400-AAD-H70ZA	SET, 'L' SIDE COWL (BLACK-1).....	1	1	1	1
*CARRIER REAR.....			77400-AAD-H70ZB	SET, 'L' SIDE COWL (BLACK-2).....	1	1	1	1
			77400-AAD-H70ZC	SET, 'L' SIDE COWL (CLOUD SILVER ME.)	1	1	1	1
			77400-AAD-H70ZD	SET, 'L' SIDE COWL (CANDY BLAZING RED)	1	1	1	1
			77400-AAD-H70ZE	SET, 'L' SIDE COWL (EXCELLENT BLUE ME.)...	1	1	1	1
			77400-AAD-H70ZF	SET, 'L' SIDE COWL (HI-GRANITE BLUE ME.) ...	1	1	1	1
			77400-AAD-H70ZG	SET, 'L' SIDE COWL (PALACE MAROON ME.) ...	1	1	1	1
			77400-AAD-H70ZH	SET, 'L' SIDE COWL (HEAVY GRAY ME.).....	1	1	1	1
		11	81200-KWH-970	CARRIER REAR	1	1	1	1
		12	83551-300-000	GROMMET, AIR CLEANER CASE	2	2	2	2
		13	84103-KCC-900	CAP, CARRIER RR.....	2	2	2	2
		14	84702-KCC-900	COLLAR, STAY NO. PLATE SET	4	4	4	4
		15	90107-428-000	BOLT, 'B' SPECIAL 6 MM	1	1	1	1
		16	90563-355-000	WASHER, WHEEL, 6 MM.....	4	4	4	4
		17	90810-KCC-910	RUBBER, STOPPER	2	2	2	2
		18	93913-24320	SCREW, TAPPING, 4 X 14	4	4	4	4

F - 12
SET ASSY./RR. COWL/
REAR CARRIER

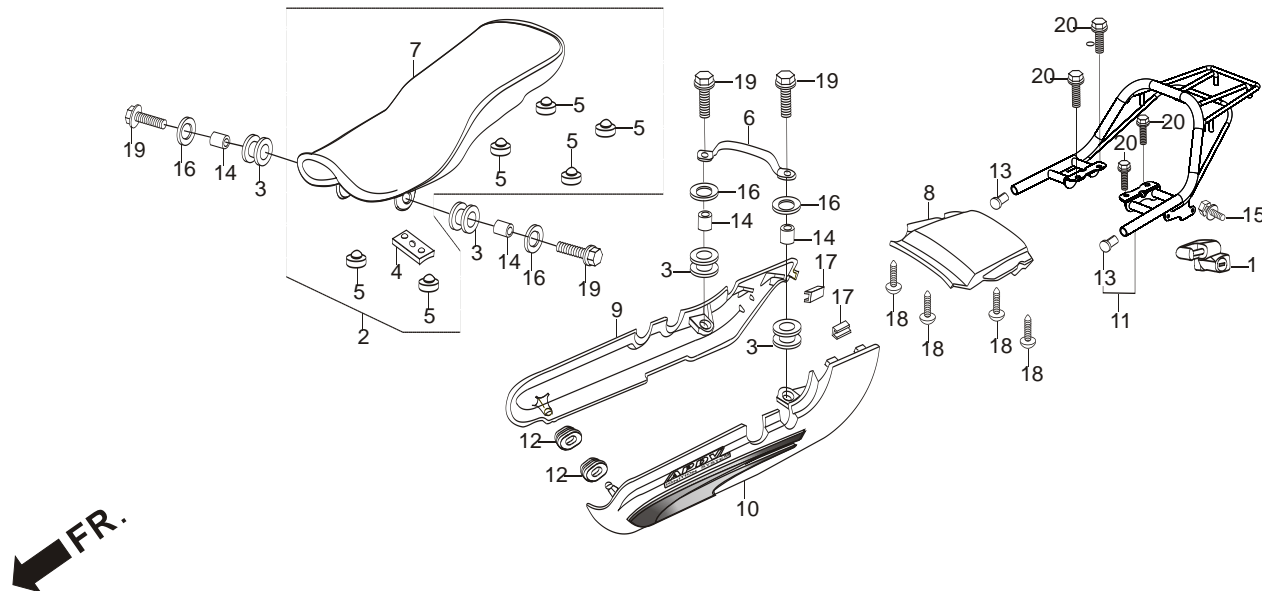

Service Item	F.R.T.	Ref. No.	Part No.	Description	Reqd. No. SPLENDOR PRO			
					DRUM			
					KICK		SELF	
SPOKE	CAST	SPOKE	CAST					
*SEAT ASSY., DOUBLE	0.1	19	95701-06025-18	BOLT, FLANGE, 6 X 25.....	4	4	4	4
*SET, CENTER RR. COWL		20	95701-08016-00	BOLT, FLANGE, 8 X 16.....	4	4	4	4
*SET, RIGHT SIDE COWL.....								
*SET, LEFT SIDE COWL								
*CARRIER REAR.....								

F - 13 FUEL TANK

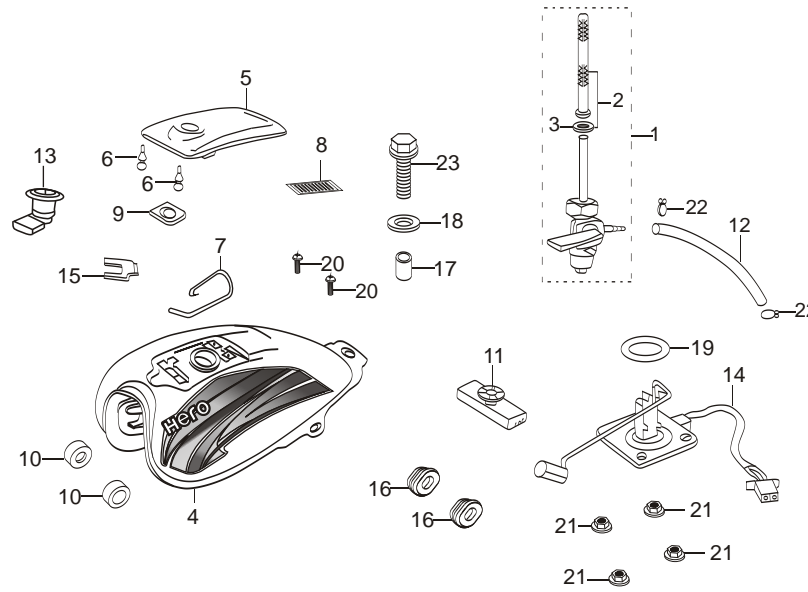

FR.

Service Item	F.R.T.	Ref. Part No.	Description	Reqd. No. SPLENDOR PRO			
				DRUM			
				KICK		SELF	
				SPOKE	CAST	SPOKE	CAST
*COCK ASSY., FUEL	0.2	1 16950-KWH-970	COCK ASSY., FUEL	1	1	1	1
*SCREEN, FUEL STRAINER.....		2 16952-KWH-970	SCREEN FUEL STRAINER	1	1	1	1
*TANK SET, FUEL.....	0.3	3 16958-397-770	O-RING.....	1	1	1	1
*LID COMP., FUEL TANK.....		4 17500-AAD-H70ZA	SET, FUEL TANK (BLACK-1)	1	1	1	1
*UNIT ASSY., FUEL		17500-AAD-H70ZB	SET, FUEL TANK (BLACK-2)	1	1	1	1
		17500-AAD-H70ZC	SET, FUEL TANK (CLOUD SILVER ME.)	1	1	1	1
		17500-AAD-H70ZD	SET, FUEL TANK (CANDY BLAZING RED).....	1	1	1	1
		17500-AAD-H70ZE	SET, FUEL TANK (EXCELLENT BLUE ME.).....	1	1	1	1
		17500-AAD-H70ZF	SET, FUEL TANK (HI-GRANITE BLUE ME.).....	1	1	1	1
		17500-AAD-H70ZG	SET, FUEL TANK (PALACE MAROON ME.).....	1	1	1	1
		17500-AAD-H70ZH	SET, FUEL TANK (HEAVY GRAY ME.)	1	1	1	1
		5 17511-KWH-970ZA	LID COMP., FUEL TANK (BLACK-1).....	1	1	1	1
		17511-KWH-970ZC	LID COMP., FUEL TANK (CLOUD SILVER ME.).....	1	1	1	1
		17511-KWH-970ZD	LID COMP., FUEL TANK (CANDY BLAZING RED)...	1	1	1	1
		17511-KWH-970ZE	LID COMP., FUEL TANK (EXCELLENT BLUE ME.)	1	1	1	1
		17511-KWH-970ZF	LID COMP., FUEL TANK (HI-GRANITE BLUE ME.)	1	1	1	1
		17511-KWH-970ZG	LID COMP., FUEL TANK (PALACE MAROON ME.)..	1	1	1	1
		17511-KWH-970ZH	LID COMP., FUEL TANK (HEAVY GRAY ME.).....	1	1	1	1
		6 17512-KCC-900	STOPPER, TANK LID.....	2	2	2	2

F - 13 FUEL TANK

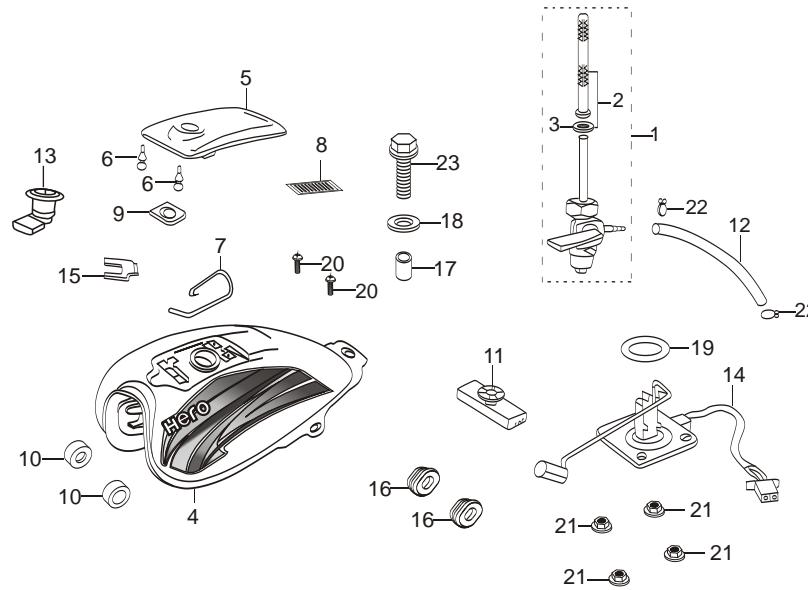

FR.

Service Item	F.R.T.	Ref. No.	Part No.	Description	Reqd. No. SPLENDOR PRO			
					DRUM			
					KICK		SELF	
					SPOKE	CAST	SPOKE	CAST
* COCK ASSY., FUEL	0.2	7	17512-KWH-970	SPRING FUEL LID OPEN	1	1	1	1
* SCREEN, FUEL STRAINER		8	17521-KWH-970	FILM HINGE	1	1	1	1
* TANK SET, FUEL	0.3	9	17525-KCC-900	SPACER, FUEL TANK LID	1	1	1	1
* LID COMP., FUEL TANK		10	17611-KCC-900	CUSHION, FR. FUEL TANK	2	2	2	2
* UNIT ASSY., FUEL		11	17613-KCC-900	CUSHION, RR. TANK	1	1	1	1
		12	17681-KWH-970	TUBE FUEL	1	1	1	1
		13	37230-KWH-961	LOCK FILLER LID	1	1	1	1
		14	37800-KWH-962	UNIT ASSY., FUEL	1	1	1	1
		15	75581-673-000	SET SPRING, LOCK KEY	1	1	1	1
		16	83551-300-000	GROMMET, AIR CLEANER CASE	2	2	2	2
		17	90324-KCC-900	COLLAR, 8 MM	1	1	1	1
		18	90325-KCC-900	WASHER, PLAIN, 8 MM	1	1	1	1
		19	91305-MC7-000	O-RING, 39.5 X 5	1	1	1	1
		20	93500-05006-OH	SCREW, PAN, 5 X 6	2	2	2	2
		21	94050-06000	NUT, FLANGE., 6 MM	4	4	4	4
		22	95002-02080	CLIP, TUBE	2	2	2	2
		23	95701-08035-08	BOLT, FLANGE, 8 X 35	1	1	1	1

F - 14
SIDE COVER

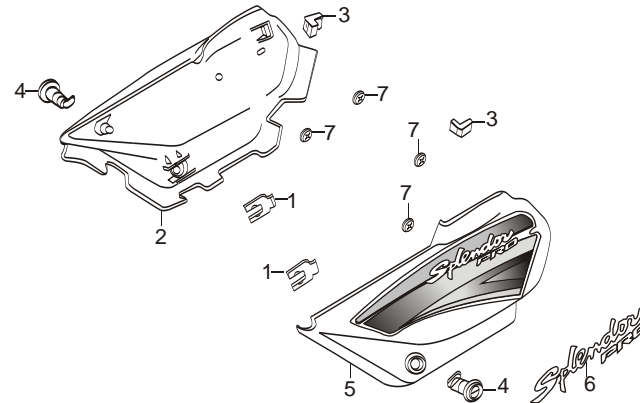

FR.

Service Item	F.R.T.	Ref. No.	Part No.	Description	Reqd. No. SPLENDOR PRO			
					DRUM			
					KICK		SELF	
					SPOKE	CAST	SPOKE	CAST
*SET, RIGHT SIDE COVER.....	0.1	1	75581-673-000	SET SPRING, LOCK KEY	2	2	2	2
*SET, LEFT SIDE COVER	0.1	2	83500-AAD-H70ZA	SET, 'R' SIDE COVER NH-1(BLACK-1)	1	1	1	1
			83500-AAD-H70ZB	SET, 'R' SIDE COVER NH-1(BLACK-2)	1	1	1	1
			83500-AAD-H70ZC	SET, 'R' SIDE COVER (CLOUD SILVER ME.)	1	1	1	1
			83500-AAD-H70ZD	SET, 'R' SIDE COVER (CANDY BLAZING RED)	1	1	1	1
			83500-AAD-H70ZE	SET, 'R' SIDE COVER (EXCELLENT BLUE ME.)	1	1	1	1
			83500-AAD-H70ZF	SET, 'R' SIDE COVER (HI-GRANITE BLUE ME.)	1	1	1	1
			83500-AAD-H70ZG	SET, 'R' SIDE COVER (PALACE MAROON ME.)	1	1	1	1
			83500-AAD-H70ZH	SET, 'R' SIDE COVER (HEAVY GRAY ME.)	1	1	1	1
		3	83502-KCC-900	GROMMET, SIDE COVER	2	2	2	2
		4	83550-KWH-961	LOCK, SIDE COVER	2	2	2	2
		5	83600-AAD-H70ZA	SET, 'L' SIDE COVER NH-1(BLACK-1)	1	1	1	1
			83600-AAD-H70ZB	SET, 'L' SIDE COVER NH-1(BLACK-2)	1	1	1	1
			83600-AAD-H70ZC	SET, 'L' SIDE COVER (CLOUD SILVER ME.)	1	1	1	1
			83600-AAD-H70ZD	SET, 'L' SIDE COVER (CANDY BLAZING RED)	1	1	1	1
			83600-AAD-H70ZE	SET, 'L' SIDE COVER (EXCELLENT BLUE ME.)	1	1	1	1
			83600-AAD-H70ZF	SET, 'L' SIDE COVER (HI-GRANITE BLUE ME.)	1	1	1	1
			83600-AAD-H70ZG	SET, 'L' SIDE COVER (PALACE MAROON ME.)	1	1	1	1
			83600-AAD-H70ZH	SET, 'L' SIDE COVER (HEAVY GRAY ME.)	1	1	1	1

F - 14
SIDE COVER

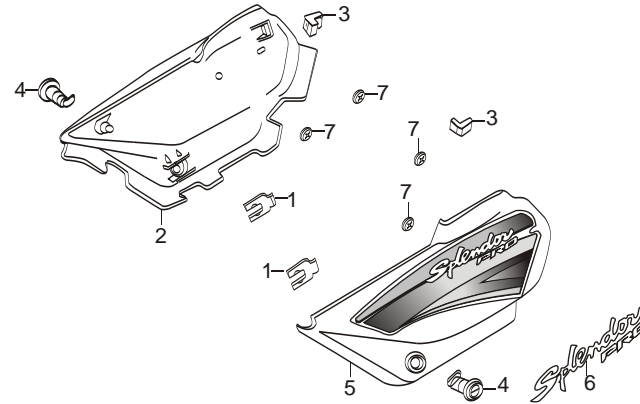

FR.

Service Item	F.R.T.	Ref. No.	Part No.	Description	Reqd. No. SPLENDOR PRO			
					DRUM			
					KICK		SELF	
SPOKE	CAST	SPOKE	CAST					
*SET, RIGHT SIDE COVER.....	0.1	6	87117-KWH-970	EMBLEM, SIDE COVER.....	2	2	2	2
*SET, LEFT SIDE COVER.....	0.1	7	90313-172-000	NUT, SPEED, 4 MM.....	4	4	4	4

F - 15 AIR CLEANER

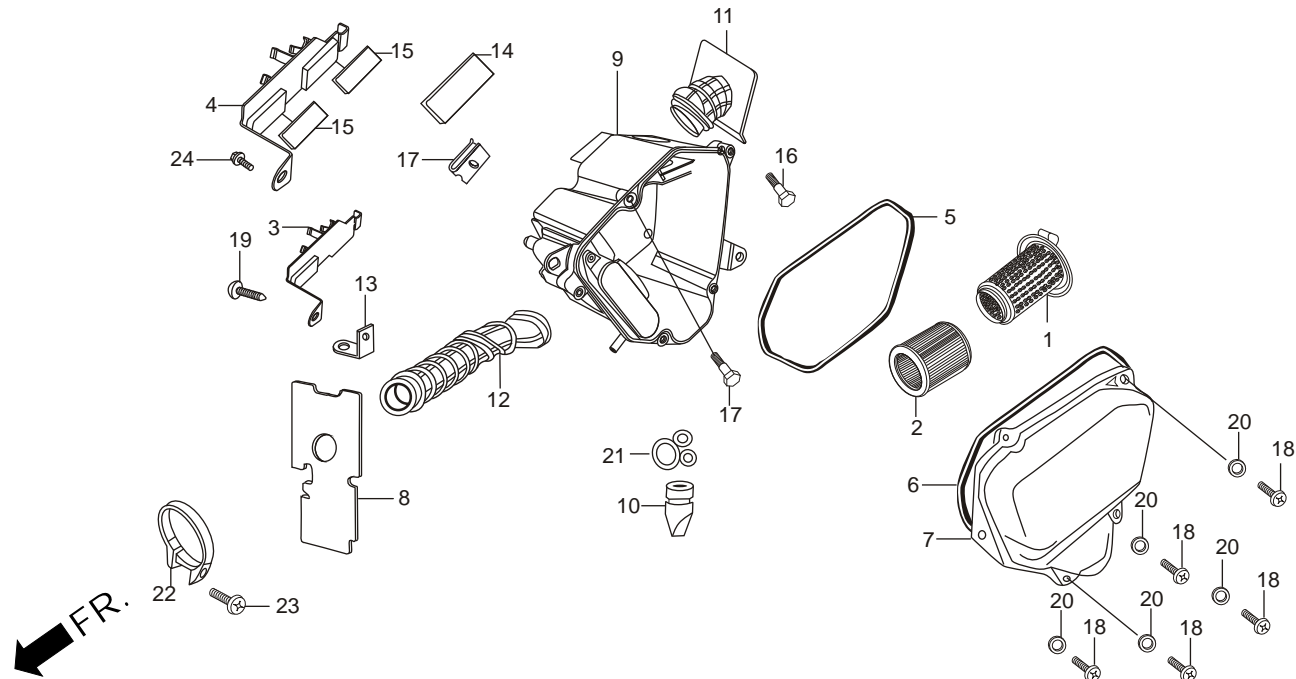

Service Item	F.R.T.	Ref. No.	Part No.	Description	Reqd. No. SPLENDOR PRO			
					DRUM			
					KICK		SELF	
					SPOKE	CAST	SPOKE	CAST
* ELEMENT 'A' AIR CLEANER	0.2	1	17212-KTC-900	HOLDER, ELEMENT	1	1	1	1
* HOLDER, ELEMENT		2	17213-KWA-940	ELEMENT, AIR/C	1	1	1	1
* ELEMENT 'B' AIR CLEANER		3	17214-KWH-970	BAND, BATTERY	1	1	-	-
* COVER, AIR CLEANER CASE		4	17214-KWH-840	BAND, BATTERY	-	-	1	1
* WATER GUARD, FR.		5	17218-KTC-900	SEAL, A/I CLEANER	1	1	1	1
* DUCT, AIR CLEANER INLET		6	17219-KTC-900	SEAL, A/I CLEANER	1	1	1	1
* TUBE, AIR CLEANER CONNECTING .		7	17220-KWA-940	COVER, AIR/C	1	1	1	1
		8	17224-KWH-970	WATER, GUARD FR.	1	1	1	1
		9	17225-KWA-840	CASE SUB ASSY., AIR/C	1	1	1	1
		10	17234-KCC-940	TUBE, AIR/C DRAIN	1	1	1	1
		11	17251-KWA-940	DUCT, AIR/C INLET	1	1	1	1
		12	17253-KTC-900	TUBE, AIR/C CONNECTOR.	1	1	1	1
		13	17361-KWA-940	STAY, BREATHER TUBE	1	1	1	1
		14	50383-KTC-900	RUBBER, BATTERY	-	-	1	1
		15	83407-KTR-940	CUSHION BATTERY	1	1	2	2
		16	90111-187-000	BOLT, FLANGE 6MM(DIA.16MM)	2	2	2	2
		17	90311-MT3-000	NUT, CLIP 6 MM.....	1	1	1	1
		18	93500-05016-1H	SCREW, PAN 5X16	5	5	5	5
		19	93903-25120	SCREW, TAPPING,5X10	1	1	1	1
		20	94101-05000	WASHER, PLAIN 5 MM	5	5	5	5

F - 15 AIR CLEANER

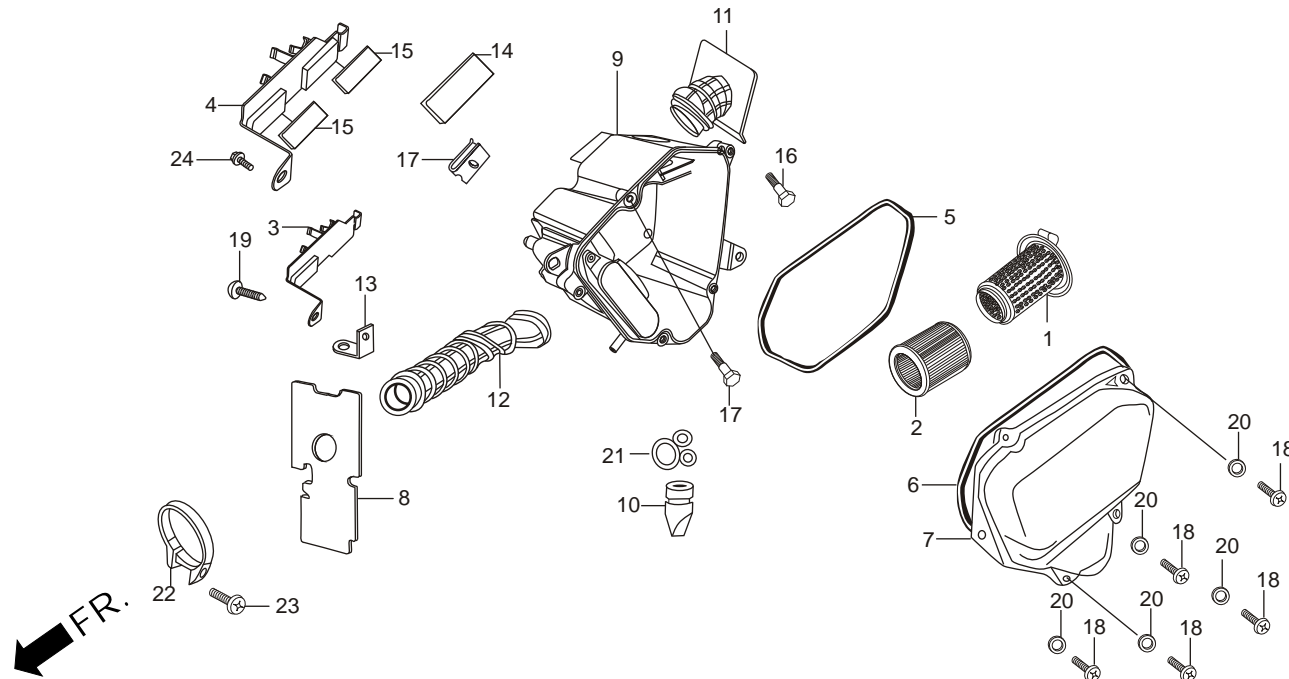

Service Item	F.R.T.	Ref. No.	Part No.	Description	Reqd. No. SPLENDOR PRO			
					DRUM			
					KICK		SELF	
					SPOKE	CAST	SPOKE	CAST
* ELEMENT 'A' AIR CLEANER	0.2	21	95002-02130	CLIP, B-12.5 TUBE	1	1	1	1
* HOLDER, ELEMENT		22	95018-46320	BAND, 46 AIR/C CONN. TUBE	1	1	1	1
* ELEMENT 'B' AIR CLEANER		23	95701-06012-08	BOLT, FLANGE 6X12	1	1	1	1
* COVER, AIR CLEANER CASE		24	95701-06016-08	BOLT, FLANGE 6X16	1	1	1	1
* WATER GUARD, FR.								
* DUCT, AIR CLEANER INLET								
* TUBE, AIR CLEANER CONNECTING .								

F - 16 EXHAUST MUFFLER

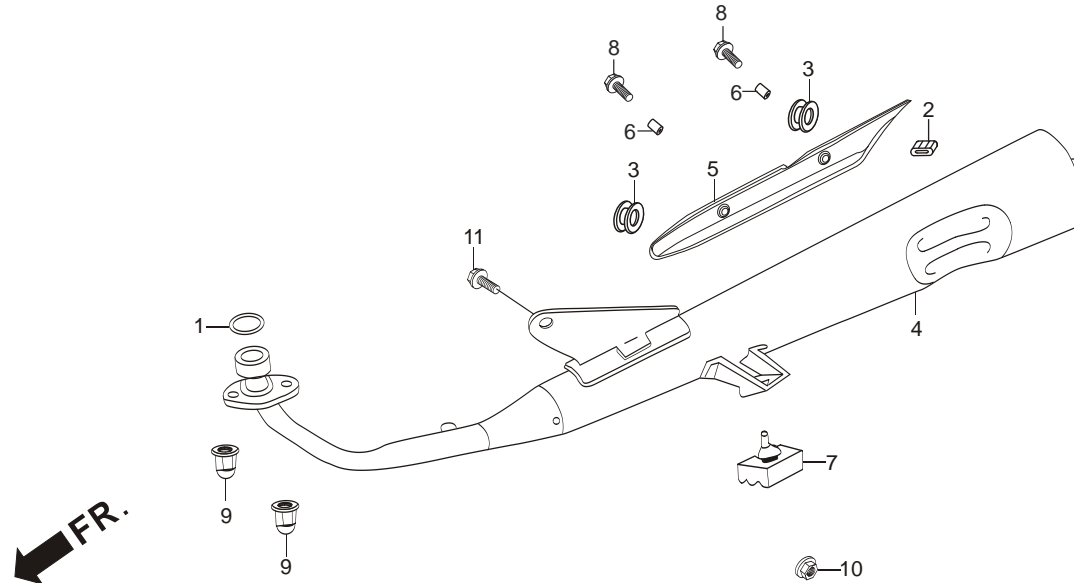

Service Item	F.R.T.	Ref. No.	Part No.	Description	Reqd. No. SPLENDOR PRO			
					DRUM			
					KICK		SELF	
SPOKE	CAST	SPOKE	CAST					
*COVER, EXH. PIPE	0.1	1	18291-KTC-900	GASKET, EXH. PIPE	1	1	1	1
*GASKET, EXH. PIPE		2	18293-KPK-900	RUBBER PKG., PROTR.	1	1	1	1
*MUFFLER COMP., EXH.	0.3	3	18345-MBT-610	RUBBER PROTECTOR MOUNT	2	2	2	2
		4	18350-AAD-H00	MUFFLER COMP., EXHAUST.....	1	1	1	1
		5	18355-KWH-970	COVER, MUFFLER	1	1	1	1
		6	33619-459-840A	COLLAR WINKER STAY	2	2	2	2
		7	50505-KCC-900	RUBBER, 'A' STAND STOPPER	1	1	1	1
		8	90107-KAN-900	BOLT, BODY COVER SET	2	2	2	2
		9	90304-438-000	NUT, HEX. CAP, 6 MM	2	2	2	2
		10	94050-08000	NUT, FLANGE, 8 MM	1	1	1	1
		11	95701-08016-00	BOLT, FLANGE, 8 X 16	1	1	1	1

F - 17 STEP ASSY./KICK STARTER

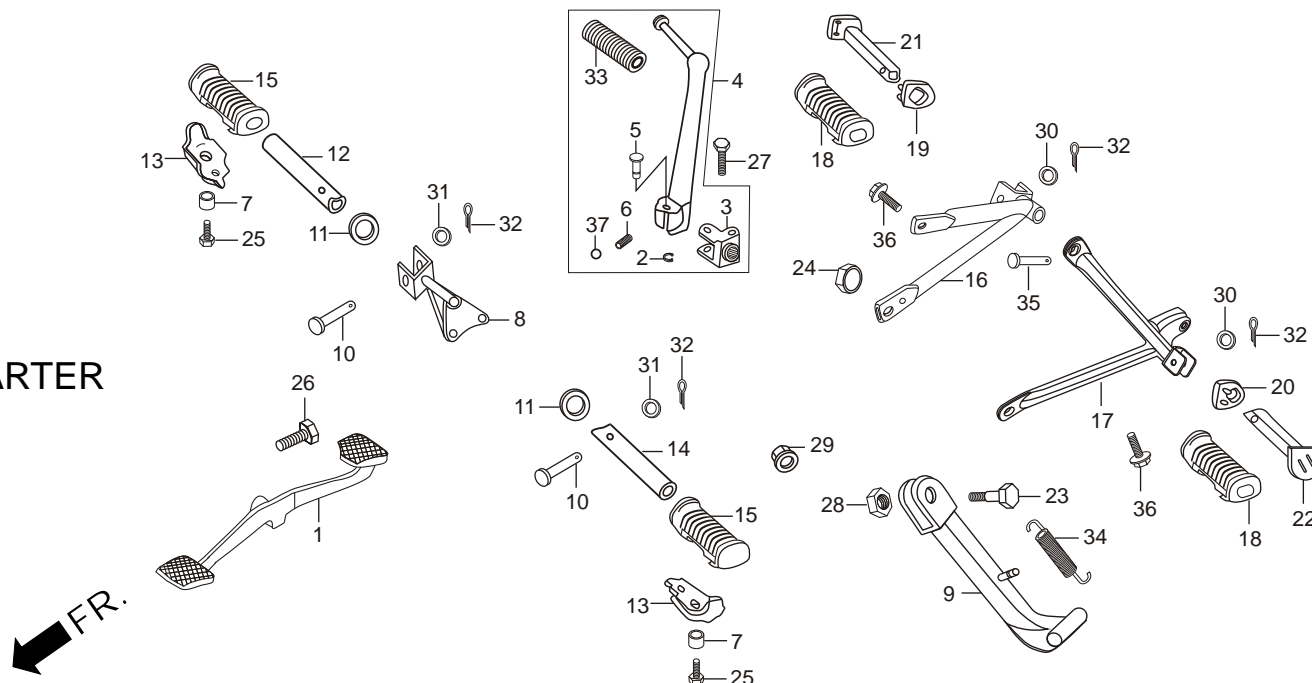

Service Item	F.R.T.	Ref. No.	Part No.	Description	Reqd. No. SPLENDOR PRO			
					DRUM			
					KICK		SELF	
					SPOKE	CAST	SPOKE	CAST
*PEDAL, GEAR CHANGE	0.1	1	24701-KWA-940	PEDAL, GEAR CHANGE	1	1	1	1
*ARM ASSY., KICK STARTER		2	28293-KAG-900	CLIP, KICK STARTER	1	1	1	1
*BAR COMP., SIDE STAND		3	28302-KWA-940	JOINT, KICK ARM	1	1	1	1
*BRACKET COMP., RIGHT/LEFT PILLION STEP		4	2830A-KWH-760	ARM, SUB ASSY., KICK STARTER	1	1	1	1
		5	28321-427-770	PIN, KICK STARTER	1	1	1	1
		6	28333-124-000	SPRING, KICK STARTER	1	1	1	1
		7	37243-323-000	COLLAR, METER SET	2	2	2	2
		8	50160-KCC-900	BRACKET, COMP., 'R' STEP	1	1	1	1
		9	50530-KCC-900	BRACKET COMP., SIDE STAND	1	1	1	1
		10	50603-KB4-000	PIN MAIN STEP BAR JOINT	2	2	2	2
		11	50614-413-000	WASHER, MAIN STEP	2	2	2	2
		12	50618-KCC-000	BRACKET 'R' STEP	1	1	1	1
		13	50619-425-010	STOPPER, STEP RUBBER	2	2	2	2
		14	50619-KCC-000	BRACKET 'L' STEP	1	1	1	1
		15	50661-425-670	RUBBER, STEP	2	2	2	2
		16	50701-KWA-830	BRACKET COMP. 'R' PILLION STEP	1	1	1	1
		17	50702-KST-940	BRACKET COMP., 'L' PILLION STEP	1	1	1	1
		18	50710-461-770	STEP, PILLION RUBBER	2	2	2	2
		19	50712-438-730	WASHER 'R' PILLION STEP	1	1	1	1
		20	50713-438-730	WASHER 'L' PILLION STEP	1	1	1	1

F - 17 STEP ASSY./KICK STARTER

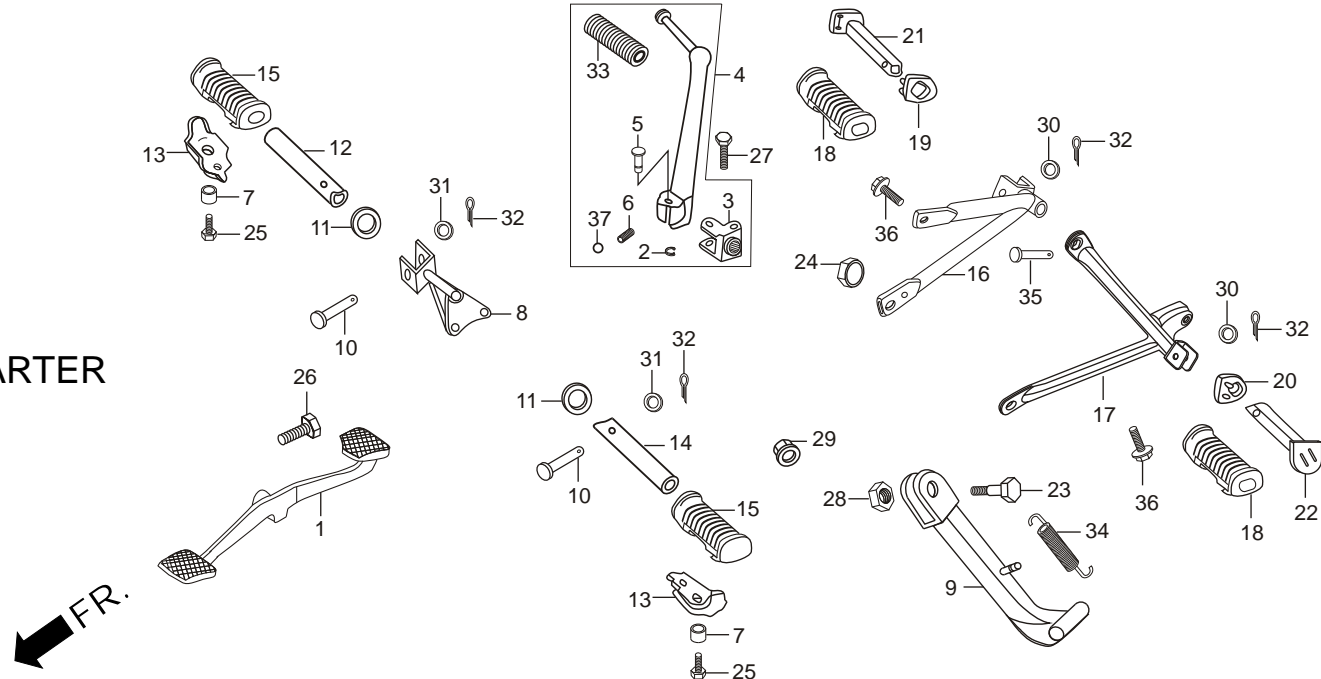

Service Item	F.R.T.	Ref. No.	Part No.	Description	Reqd. No. SPLENDOR PRO			
					DRUM			
					KICK		SELF	
					SPOKE	CAST	SPOKE	CAST
*PEDAL, GEAR CHANGE	0.1	21	50715-KCC-900	BAR R., PILLION STEP	1	1	1	1
*ARM ASSY., KICK STARTER		22	50718-KCC-900	BAR L., PILLION STEP	1	1	1	1
*BAR COMP., SIDE STAND		23	90108-223-000	SCREW, SIDE STAND PIVOT	1	1	1	1
*BRACKET COMP., RIGHT/LEFT PILLION STEP		24	90304-KTE-911	NUT, FLG.PT.10 MM	1	1	1	1
		25	92000-06016-0A	BOLT HEX., 6X16	2	2	2	2
		26	92000-06020-0H	BOLT HEX., 6X20	1	1	1	1
		27	92101-06032-0A	BOLT HEX., 6X32	1	1	1	1
		28	94030-10000	NUT HEX., 10MM	1	1	1	1
		29	94050-05000	NUT, FLANGE 5MM	1	1	1	1
		30	94101-06000	WASHER, PLAIN 6 MM	2	2	2	2
		31	94101-08000	WASHER, PLAIN 8 MM	2	2	2	2
		32	94201-16150	PIN, SPLIT 1.6X15 MM	4	4	4	4
		33	95011-51000	STARTER, RUBBER A KICK	1	1	1	1
		34	95014-72302	SPRING, 'C' SIDE STAND	1	1	1	1
		35	95015-81000	PIN, 'A' PILLION STEP	1	1	1	1
		36	95701-08016-07	BOLT, FLANGE 8X16	2	2	2	2
		37	96211-08000	BALL, STEEL 8 MM	1	1	1	1

F - 18 MAIN STAND/PEDAL BRAKE

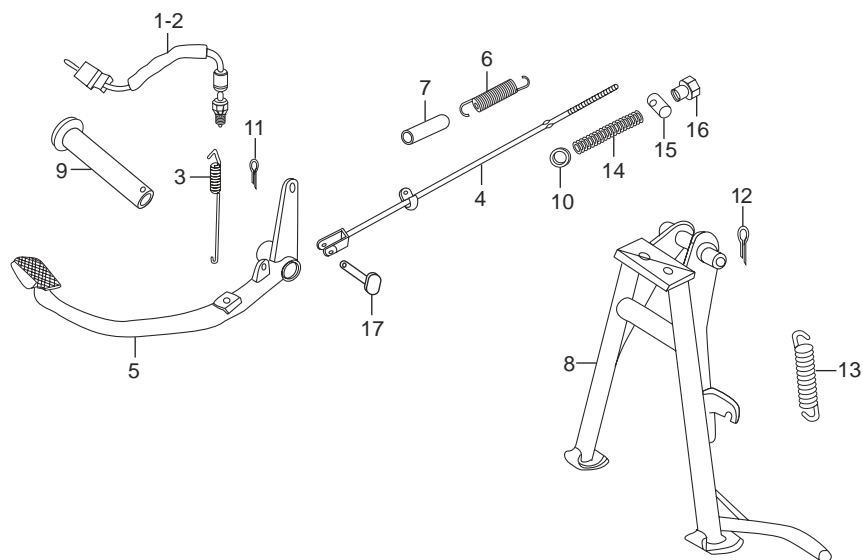

FR.

Service Item	F.R.T.	Ref. No.	Part No.	Description	Reqd. No. SPLENDOR PRO			
					DRUM			
					KICK		SELF	
					SPOKE	CAST	SPOKE	CAST
* SWITCH ASSY., RR. STOP.....	0.2	1	35350-KWH-960	SWITCH ASSY., REAR STOP (KICK).....	1	1	-	-
* ROD COMP, RR. BRAKE	0.3	2	35350-KWA-940	SWITCH ASSY., REAR STOP (SELF)	-	-	1	1
* PEDAL, BRAKE	0.5	3	35357-KCC-900	SPRING, STOP SWITCH	1	1	1	1
* SPRING, BRAKE PEDAL.....	0.1	4	43451-KCC-600	ROD, COMP .RR. BRAKE	1	1	1	1
* STAND COMP, MAIN	0.4	5	46500-KWA-910	PEDAL,, BRAKE	1	1	1	1
		6	46514-KCC-900	SPRING, BRAKE PEDAL	1	1	1	1
		7	46515-KB9-000	TUBE, BRAKE PEDAL SPRING	1	1	1	1
		8	50500-KWH-760	STAND, COMP.MAIN	1	1	1	1
		9	50512-KTC-900	PIPE RR., BRK. PIVOT	1	1	1	1
		10	90502-198-900	WASHER, BRAKE ROD	1	1	1	1
		11	94201-20150	PIN, SPLIT 2X15 MM.....	1	1	1	1
		12	94201-30250	PIN, SPLIT 3X25 MM.....	1	1	1	1
		13	95014-71702	SPRING, G MAIN STAND.....	1	1	1	1
		14	95014-73100	SPRING, 'A' BRAKE ROD	1	1	1	1
		15	95015-32001	JOINT, 'B' BRAKE ARM	1	1	1	1
		16	95015-42000	NUT, 'B' ADJUST	1	1	1	1
		17	95015-53000	PIN, 'C' JOINT.....	1	1	1	1

F - 19 REAR FORK/CHAIN CASE

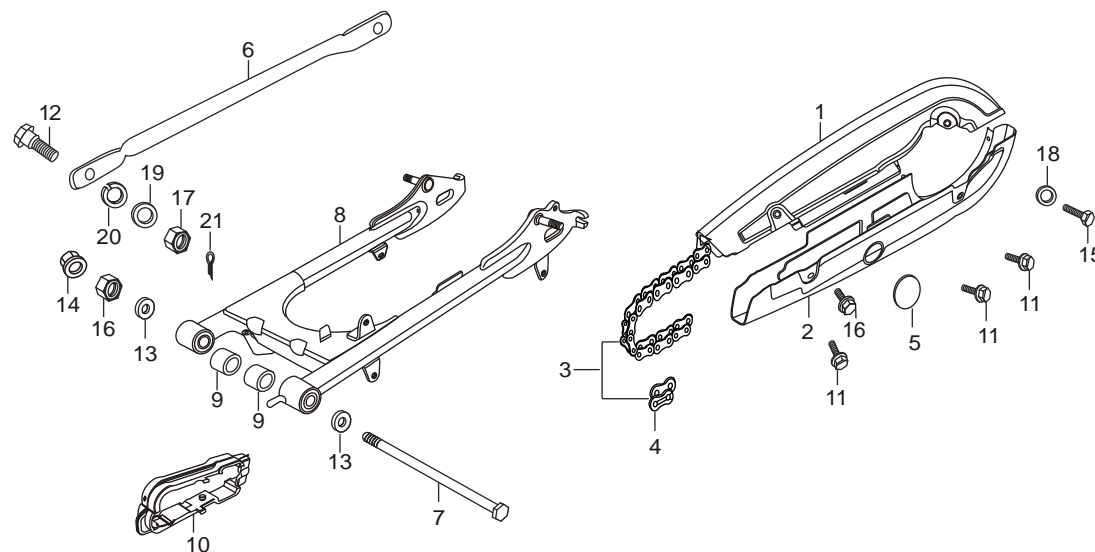

Service Item	F.R.T.	Ref. No.	Part No.	Description	Reqd. No. SPLENDOR PRO			
					DRUM			
					KICK		SELF	
					SPOKE	CAST	SPOKE	CAST
* CASE, UPPER (HALF) DRIVE CHAIN .	0.1	1	40510-KWH-970	CASE, UP (HALF) DRIVE CHAIN	1	1	1	1
(ONE OR ALL)		2	40520-KST-940Z	CASE, UND (HALF) DRIVE CHAIN (MRS)	1	1	1	1
* CHAIN, DRIVE	0.3	3	40530-KST-941	CHAIN, DRIVE TIDC 420-108	1	1	1	1
* ARM, RR BRAKE STOPPER	0.2	4	40531-KTE-912	JOINT, RJ DRIVE CHAIN	1	1	1	1
* SWING ARM COMP, RR.	0.7	5	40545-001-000	CAP, CHAIN CASE PEEP HOLE	1	1	1	1
* RUBBER BUSH, RR. FORK PIVOT	1.0	6	43431-198-900	ARM RR., BRAKE STOPPER	1	1	1	1
* PACKING, DRIVE CHAIN CASE		7	52101-KST-940	BOLT, SWINGARM PIVOT	1	1	1	1
		8	52110-AAJ-H40	SWINGARM COMP., REAR	1	1	1	1
		9	52147-KTC-900	RUBBER BUSH RR., FORK PIVOT	2	2	2	2
		10	52170-AAJ-H40	SLIDER, CHAIN	1	1	1	1
		11	90118-383-000	BOLT, WASHER 6X6	3	3	3	3
		12	90133-331-770	BOLT, HEX 8MM	1	1	1	1
		13	90183-KTC-900	WASHER, SPECIAL 12 MM	2	2	2	2
		14	90306-KTE-911	NUT, FLANGE SPL 12 MM	1	1	1	1
		15	92000-06012-0A	BOLT, HEX.6X12	1	1	1	1
		16	93401-06010-00	BOLT, WASHER 6X10	1	1	1	1
		17	94001-08000-0S	NUT, HEX 8MM	1	1	1	1
		18	94101-06000	WASHER, PLAIN 6MM	1	1	1	1
		19	94101-08000	WASHER, PLAIN 8MM	1	1	1	1

F - 19 REAR FORK/CHAIN CASE

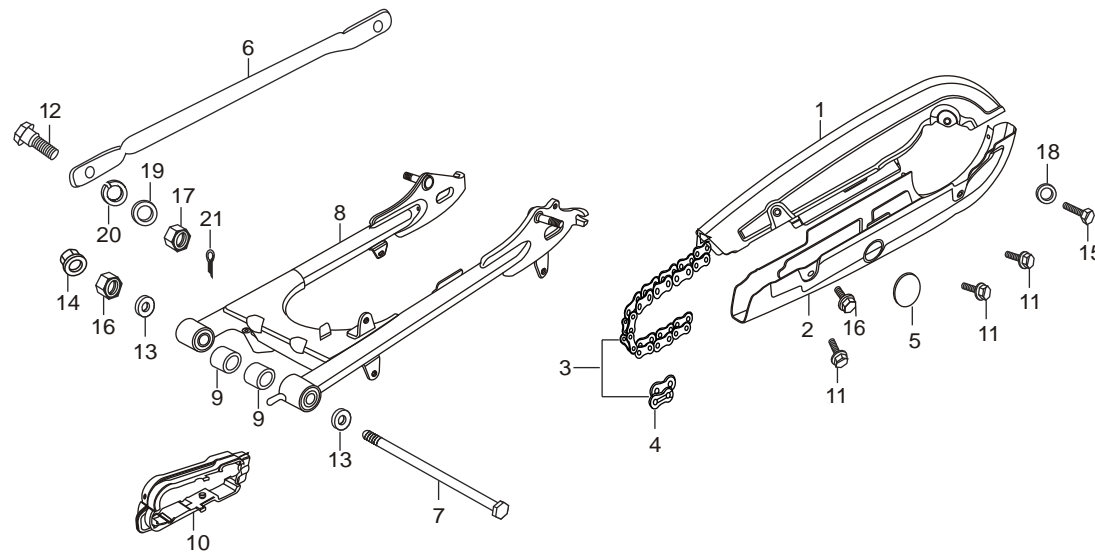

Service Item	F.R.T.	Ref. No.	Part No.	Description	Reqd. No. SPLENDOR PRO			
					DRUM			
					KICK		SELF	
					SPOKE	CAST	SPOKE	CAST
* CASE, UPPER (HALF) DRIVE CHAIN . (ONE OR ALL)	0.1	20	94111-10000	WASHER, SPRING 10 MM.....	1	1	1	1
* CHAIN, DRIVE	0.3	21	94201-20150	PIN, SPLIT 2X15 MM.....	1	1	1	1
* ARM, RR BRAKE STOPPER	0.2							
* SWING ARM COMP, RR.	0.7							
* RUBBER BUSH, RR. FORK PIVOT	1.0							
* PACKING, DRIVE CHAIN CASE								

F - 20 REAR CUSHION

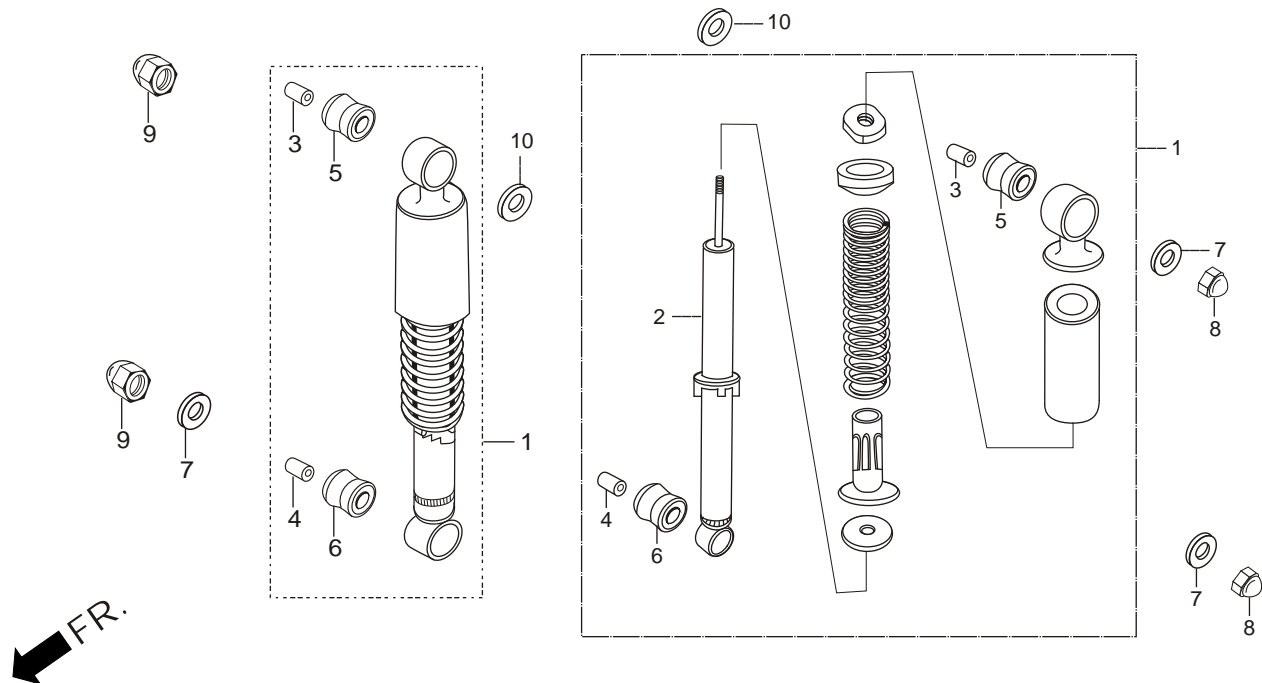

Service Item	F.R.T.	Ref. No.	Part No.	Description	Reqd. No. SPLENDOR PRO			
					DRUM			
					KICK		SELF	
					SPOKE	CAST	SPOKE	CAST
* CUSHION ASSY., RR.....	0.2	1	52400-KWH-961	CUSHION ASSY., REAR	2	2	2	2
		2	52410-KCC-871	DAMPER COMP., REAR	2	2	2	2
		3	52486-KAG-900	COLLAR, RUBBER BUSH (UNDER)	2	2	2	2
		4	52486-KTN-701	COLLAR, RUBBER BUSH	2	2	2	2
		5	52489-399-600	BUSH, RUBBER (UPPER)	2	2	2	2
		6	52495-098-000	BUSH, RUBBER (UNDER).....	2	2	2	2
		7	90551-178-000	WASHER, SPECIAL 10MM	3	3	3	3
		8	94001-10000-0S	NUT HEX., 10 MM	2	2	2	2
		9	94021-10000-0S	NUT HEX., CAP 10 MM.....	2	2	2	2
		10	94101-12800	WASHER, PLAIN 12 MM.....	2	2	2	2

F - 21 REAR FENDER

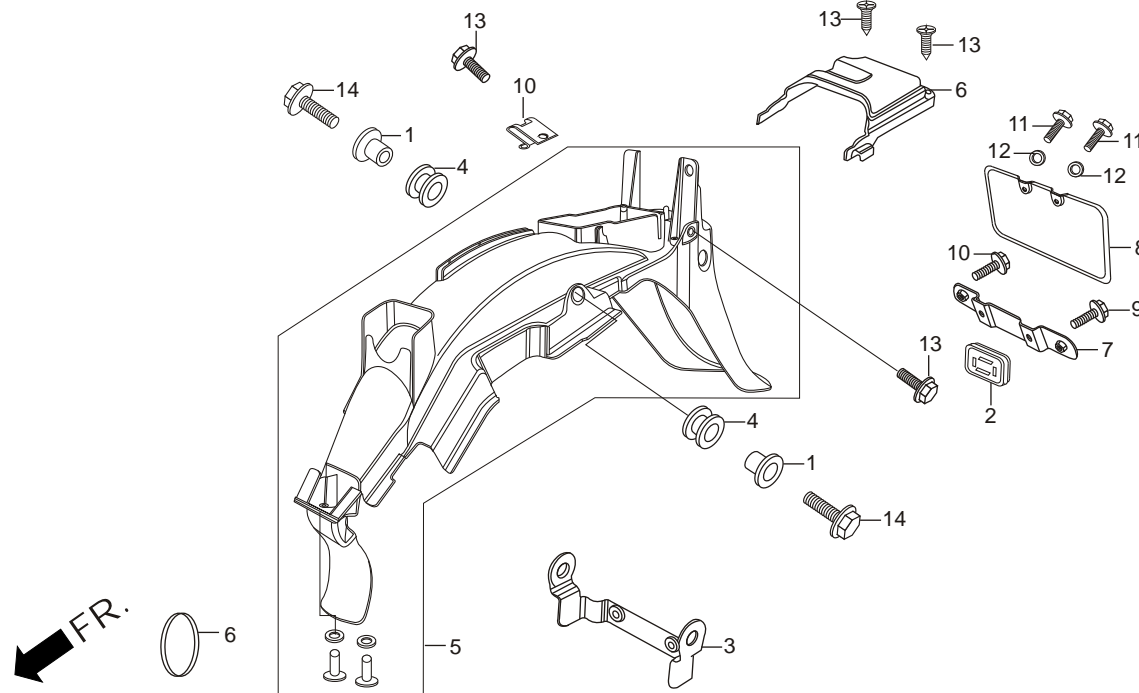

Service Item	F.R.T.	Ref. No.	Part No.	Description	Reqd. No. SPLENDOR PRO			
					DRUM			
					KICK		SELF	
					SPOKE	CAST	SPOKE	CAST
* FEMDER COMP., RR.....	0.6	1	17509-398-960	COLLAR, TANK SET	2	2	2	2
* STAY, REAR WINKER		2	33741-KST-920	REFLEX, REFLECTOR	1	1	1	1
* COVER, TOOL TRAY.....		3	50186-KCC-870	STAY, RR. WINKER	1	1	1	1
		4	77202-KCC-900	RUBBER, SEAT MTG.....	2	2	2	2
		5	80100-KWH-970	FENDER COMP., REAR.....	1	1	1	1
		6	80123-KCC-870	BAND, TOOL	1	1	1	1
		7	84701-KCC-860	BRACKET, NO. PLATE.....	1	1	1	1
		8	84701-P26-D00A	NUMBER, PLATE RR.....	1	1	1	1
		9	90111-187-000	BOLT, FLANGE 6MM (DIA.16MM).....	2	2	2	2
		10	90320-GC3-000	NUT, SPRING M5	1	1	1	1
		11	92000-06016-0A	BOLT, HEX.6X16.....	2	2	2	2
		12	94101-06000	WASHER, PLAIN 6 MM	2	2	2	2
		13	95701-06012-00	BOLT, FLANGE 6X12.....	2	2	2	2
		14	95701-06020-08	BOLT, FLANGE 6X20.....	2	2	2	2

F - 22 WINKERS

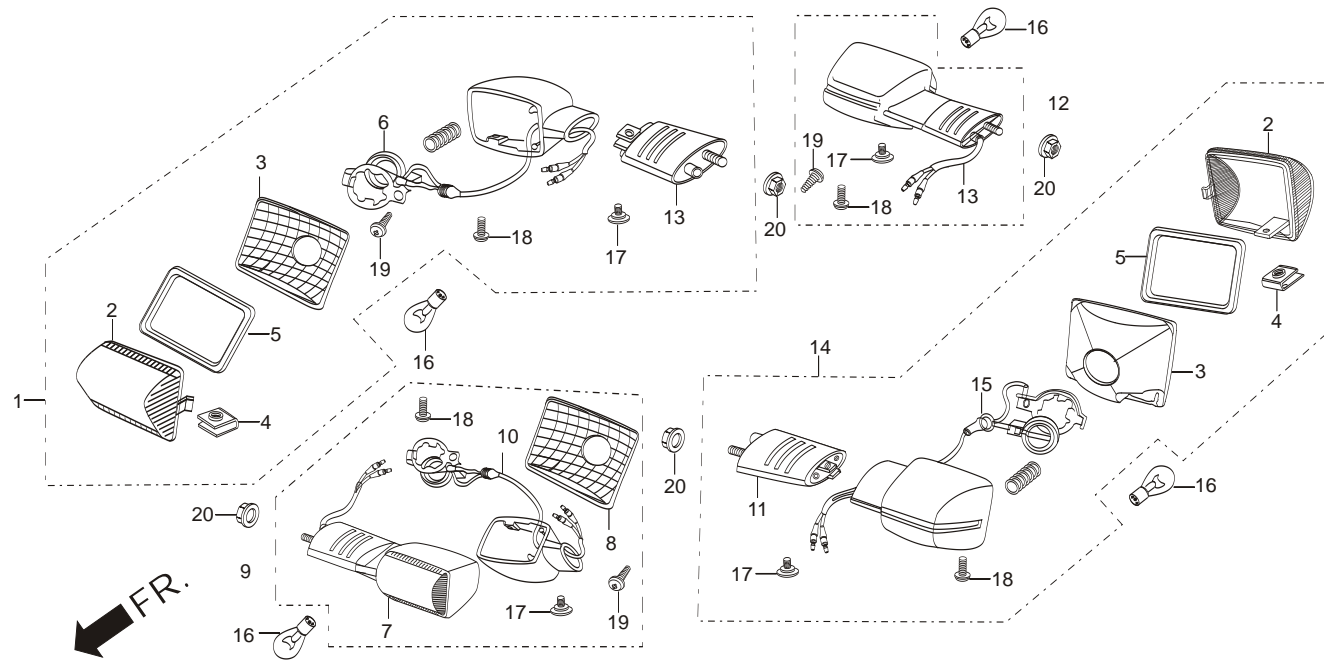

Service Item	F.R.T.	Ref. No.	Part No.	Description	Reqd. No.			
					SPLENDOR PRO			
					DRUM			
					KICK		SELF	
		SPOKE	CAST	SPOKE	CAST			
* WINKER ASSY., R/L	0.2	1	3340A-KWH-961	WINKER ASSY., 'R' FR	1	1	1	1
(ADD 0.1 FOR EACH)		2	33402-KWH-960	LENS, WINKER 'R' FR	2	2	2	2
(INC. RELATIVE PART)		3	33405-KWH-961	REFLECTOR WINKER R	1	1	1	1
* WINKER ASSY., R/L RR	0.3	4	33407-KCC-900	SPECIAL NUT	4	4	4	4
(ONE OR ALL)		5	33408-KCC-900	PACKING, LENS	4	4	4	4
(INC. RELATIVE PART)		6	33415-KWH-961	SOCKET COMP., R. WINKER FR	1	1	1	1
(EXC. RELATED PARTS BELOW)		7	33452-KWH-960	LENS, WINKER, 'L' FR	2	2	2	2
* BULB, WINKER	0.1	8	33455-KWH-961	REFLECTOR WINKER L	1	1	1	1
* WHEN SERVICING COMP., NUNIT,		9	3345A-KWH-961	WINKER ASSY., L. FR	1	1	1	1
(F.R.T. IS 0.2)		10	33465-KWH-961	SOCKET COMP., L. WINKER FR	1	1	1	1
		11	33490-KCC-900	STAY COMP., WINKER	4	4	4	4
		12	3360A-KWH-961	WINKER ASSY., 'R' RR	1	1	1	1
		13	33615-KWH-961	SOCKET COMP., R. WINKER RR	1	1	1	1
		14	3365A-KWH-961	WINKER ASSY., 'L' RR	1	1	1	1
		15	33665-KWH-961	SOCKET COMP., L. WINKER RR	1	1	1	1
		16	34930-KWA-930	BULB WINKER (12V,10W) AMBER	2	2	2	2
		17	90380-MB2-000	SCREW, SPECIAL, 6 X 8	4	4	4	4
		18	93700-04012-1G	SCREW, OVAL, 4 X 12	4	4	4	4
		19	93901-34420	SCREW, TAPPING 4X16	4	4	4	4
		20	94050-06000	NUT, FLANGE, 6 MM	4	4	4	4

F - 23 TAIL LIGHT

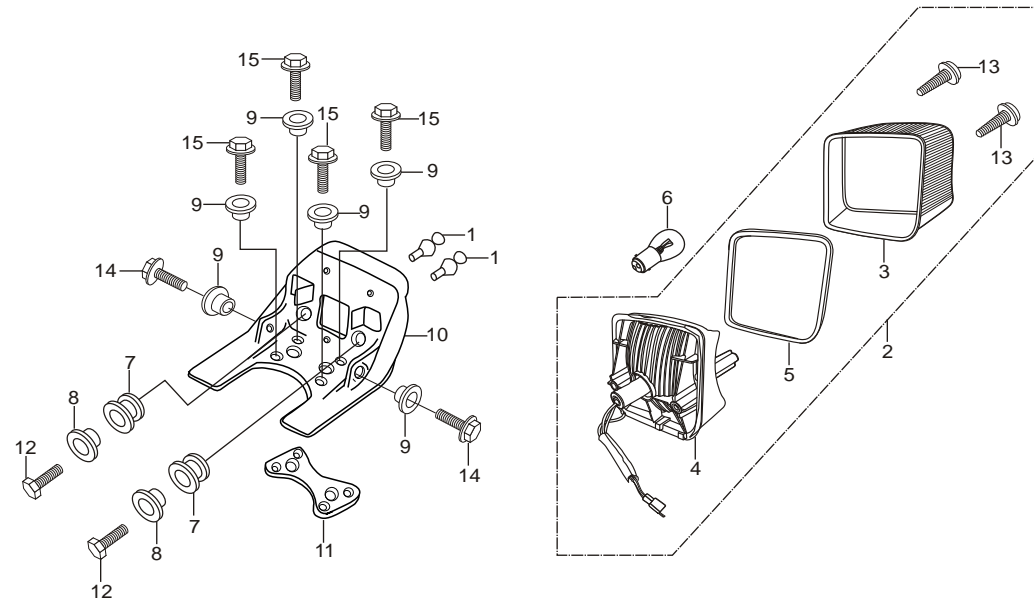

Service Item	F.R.T.	Ref. No.	Part No.	Description	Reqd. No. SPLENDOR PRO			
					DRUM			
					KICK		SELF	
					SPOKE	CAST	SPOKE	CAST
* UNIT, TAIL LIGHT.....0.4		1	17512-KCC-900	STOPPER, TANK LID.....	2	2	2	2
* LENS, TAIL LIGHT		2	33701-KST-930	UNITL TAIL LIGHT	1	1	1	1
* BASE COMP., RR.		3	33702-KCC-830	LENS, COMB.....	1	1	1	1
* BULB, TAIL LIGHT0.1		4	33704-KST-930	BASE COMP., REAR.....	1	1	1	1
		5	33709-KCC-830	PACKING, LENS.....	1	1	1	1
		6	34906-KST-920	BULB, TAIL LIGHT (R10/5W)	1	1	1	1
		7	61103-357-000	RUBBER, FR. FENDER MOUNT	2	2	1	1
		8	61104-KM7-910	COLLAR, FAIRING	2	2	1	1
		9	61107-KK6-000	WASHER, 6 MM	6	6	1	1
		10	80102-KCC-900	BASE, TAIL LIGHT.....	1	1	1	1
		11	80150-KCC-900	PLATE, REAR FENDER	1	1	1	1
		12	92000-05022-0H	BOLT, HEX., 5 X 22	2	2	2	2
		13	93901-24510	SCREW, TAPPING, 4 X 20.....	2	2	2	2
		14	95701-06018-08	BOLT, FLANGE, 6 X 18	2	2	2	2
		15	96001-06016-00	BOLT, FLANGE, SH. 6 X 16	4	4	4	4

F - 24 WIRE HARNESS/BATTERY

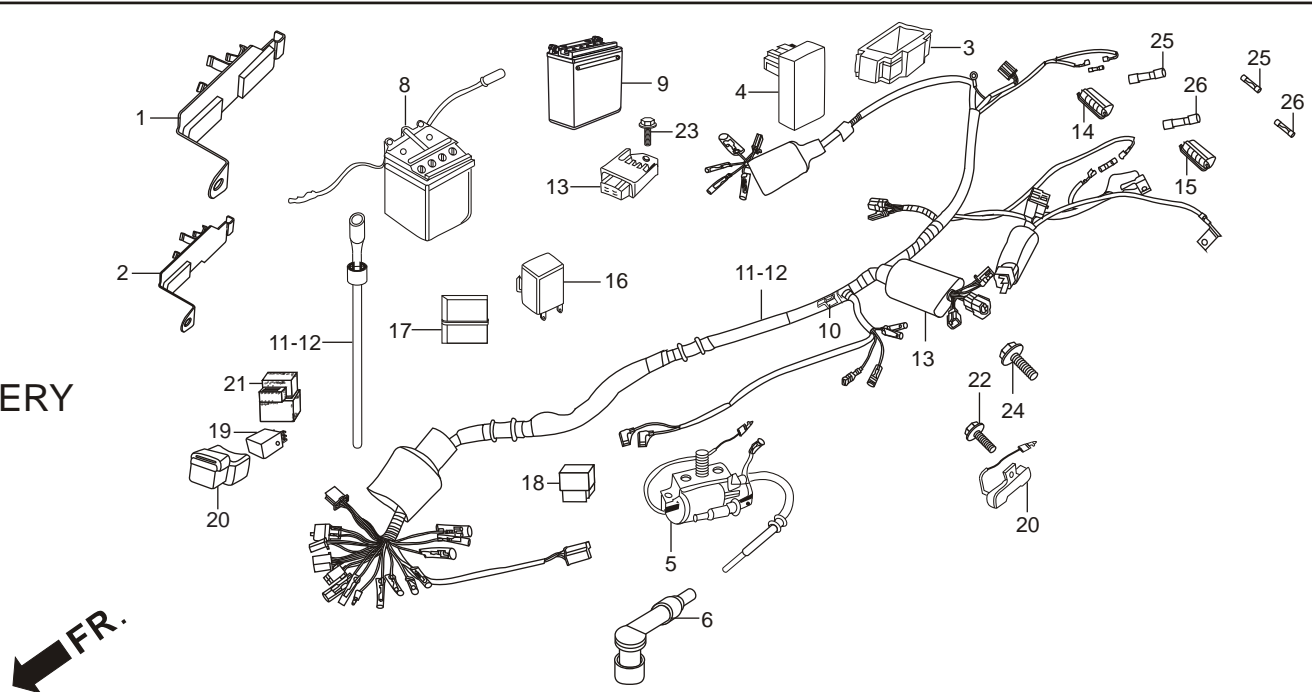

Service Item	F.R.T.	Ref. No.	Part No.	Description	Reqd. No. SPLENDOR PRO			
					DRUM			
					KICK		SELF	
					SPOKE	CAST	SPOKE	CAST
* UNIT COMP., C.D.I.	0.4	1	17214-KWH-970	BAND, BATTERY.....	1	1	-	-
* COIL ASSY., IGNITION		2	17214-KWH-970	BAND, BATTERY.....	-	-	1	1
* RECTIFIER COMP., REGULATOR		3	30401-KWH-961	CUSHION CDI, UNIT	1	1	1	1
* BATTERY ASSY.,		4	30410-KWH-961	UNIT COMP. CDI	1	1	1	1
* RELAY COMP., WINKER		5	30500-AAF-H00	COIL ASSY., IGN.	1	1	1	1
* HARNESS, WIRE	0.9							
* RESISTOR ASY.,		6	30700-KSP-B01	CAP, ASSY. NOISE SUPPRESSOR.....	1	1	1	1
		7	31500-KVT-801	BATTERY ASSY.,	-	-	1	1
		8	31500-KWS-801	BATTERY ASSY.,	1	1	-	-
		9	31600-KWF-841	REGULATOR RECT., COMP.....	1	1	1	1
		10	31700-124-000	RECTIFIER, ASSY., SILICON	-	-	1	1
		11	32100-KWH-960	HARNESS, WIRE (KICK)	1	1	-	-
		12	32100-KWH-970	HARNESS, WIRE (SELF)	-	-	1	1
		13	32108-344-820	COVER, CONNECTOR	1	1	-	-
		14	38210-KWA-831	CASE 10A FUSE	1	1	-	-
		15	38210-KWA-831	CASE 15A FUSE	1	1	2	2
		16	38301-KWH-961	RELAY COMP., WINKER	1	1	1	1
		17	38306-GE7-000	SUSP., WINKER RELAY	1	1	1	1
		18	38501-KWH-971	RELAY, COMP., START	1	1	1	1
		19	38502-KSP-910	RELAY COMP., POWER	1	1	1	1
		20	38506-KWA-840	SUSPENSION. POWER, RELAY	1	1	1	1

F - 24 WIRE HARNESS/BATTERY

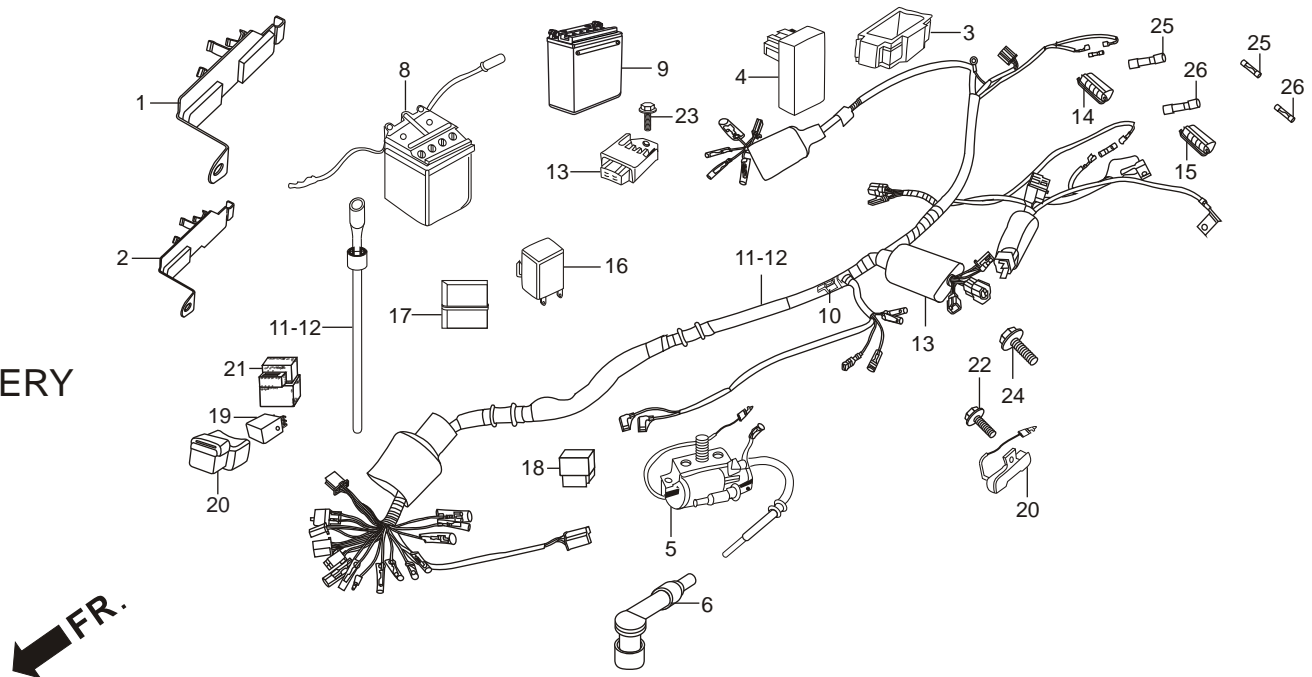

Service Item	F.R.T.	Ref. No.	Part No.	Description	Reqd. No. SPLENDOR PRO			
					DRUM			
					KICK		SELF	
					SPOKE	CAST	SPOKE	CAST
* UNIT COMP., C.D.I.	0.4	21	38506-KWA-940	SUSPENSION , START, RELAY	1	1	1	1
* COIL ASSY., IGNITION		22	95701-06012-08	BOLT, FLANGE 6X12.....	1	1	-	-
* RECTIFIER COMP., REGULATOR.....		23	95701-06014-18	BOLT, FLANGE 6X14.....	2	2	-	-
* BATTERY ASSY.,.....		24	96001-06020-00	BOLT, FLANGE SH.6X20.....	2	2	1	1
* RELAY COMP., WINKER								
* HARNESS, WIRE	0.9	25	98200-31000	FUSE A10	2	2	1	1
* RESISTOR ASY.,		26	98200-31500	FUSE A15	2	2	1	1

F - 25 FRAME BODY/UTILITY BOX

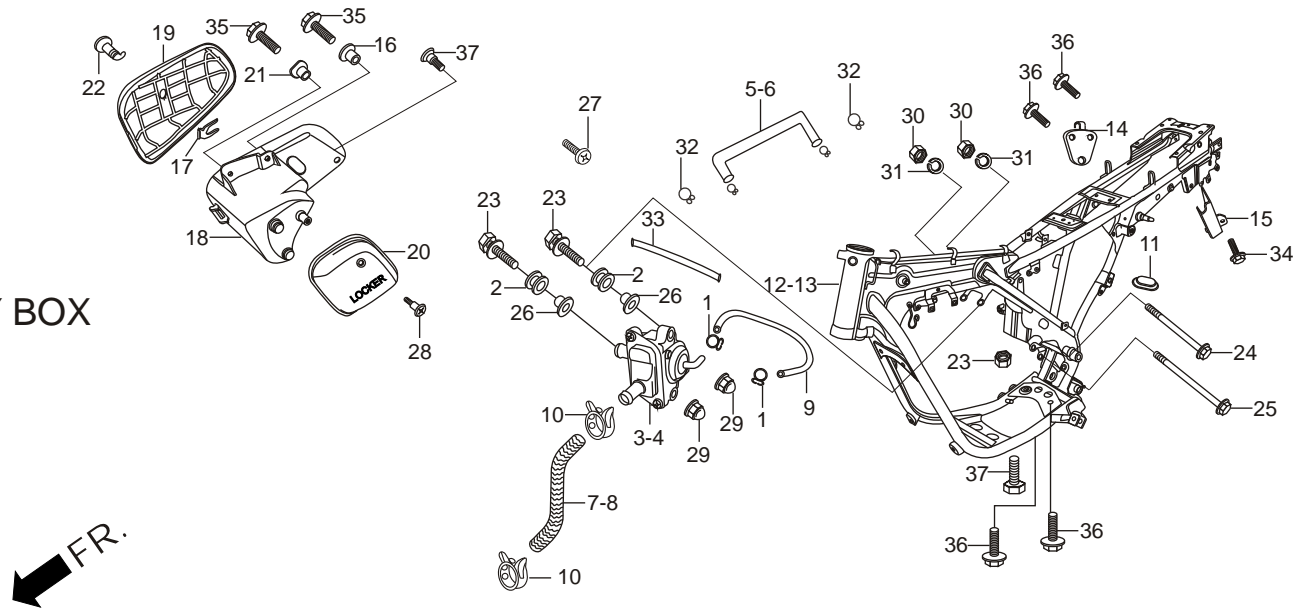

Service Item	F.R.T.	Ref. No.	Part No.	Description	Reqd. No. SPLENDOR PRO			
					DRUM			
					KICK		SELF	
					SPOKE	CAST	SPOKE	CAST
* BODY COMP., FRAME	5.0	1	17369-198-770	CLIP, BREATHER, TUBE	2	2	2	2
* UTILITY BOX COMP.,		2	17622-GB7-900	RUBBER, CUSHION	2	2	2	2
(INC. RELATIVE PART)		3	18600-KWA-930	VALVE, ASSY., AIR, SUCTION.....	1	1	-	-
		4	18600-KWA-940	VALVE, ASSY., AIR, SUCTION.....	1	1	-	-
		5	18651-KCC-940	TUBE, ASV	1	1	-	-
		6	18651-KWA-940	TUBE, 'A' ASV	-	-	1	1
		7	18652-KCC-940	TUBE, 'B' ASV	1	1	-	-
		8	18652-KWA-940	TUBE, 'B' ASV	-	-	1	1
		9	18653-198-D00	TUBE, ASV CONTROL.....	1	1	-	-
		10	19509-198-770	CLAMP, D-16 TUBE	2	2	2	2
		11	32712-ZA0-000	GROMMET, TERM/C.....	1	1	1	1
		12	50100-KWH-960	FRAME, BODY COMP. (KICK).....	1	1	-	-
		13	50100-KWH-970	FRAME, BODY COMP. (SELF)	-	-	1	1
		14	50211-KCC-900	PLATE, ENG.HANGER	1	1	1	1
		15	50250-KCC-870	COVER, SEAT LOCK, CABLE	1	1	1	1
		16	61107-KK6-000	WASHER, 6 MM.....	1	1	1	1
		17	75581-673-000	SET, SPRING LOCK KEY	1	1	1	1
		18	83510-KWH-970	UTILITY BOX, COMP.,	1	1	1	1
		19	83512-KWH-970	COVER 'R' UTILITY BOX.....	1	1	1	1

F - 25 FRAME BODY/UTILITY BOX

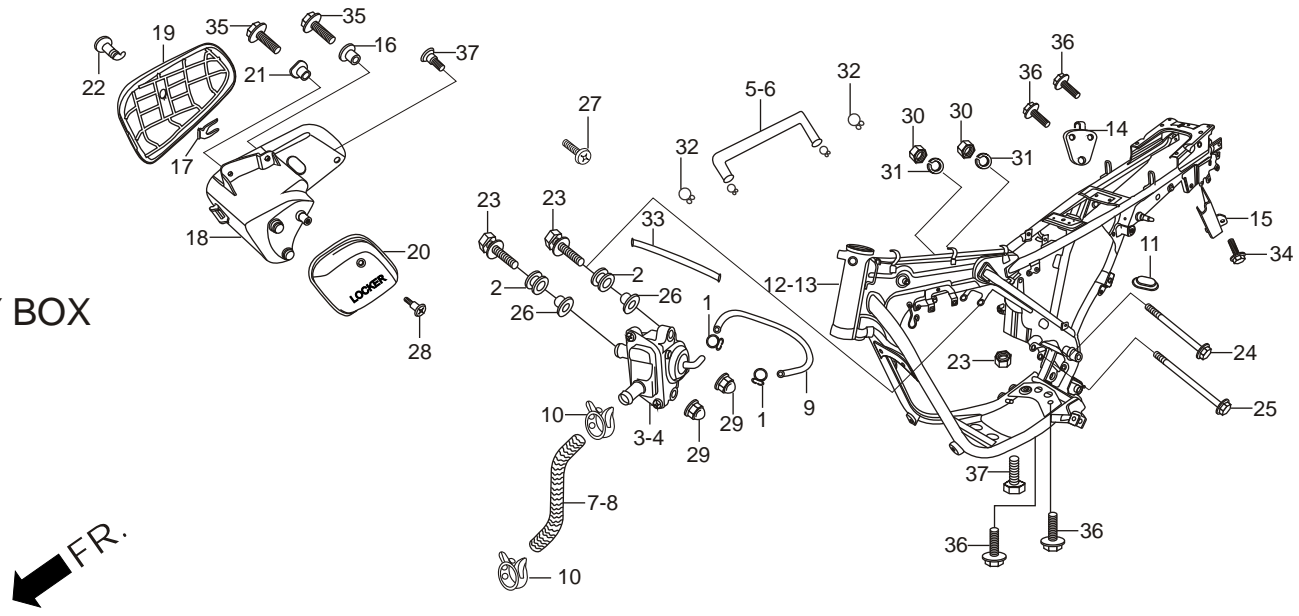

Service Item	F.R.T.	Ref. No.	Part No.	Description	Reqd. No. SPLENDOR PRO			
					DRUM			
					KICK		SELF	
					SPOKE	CAST	SPOKE	CAST
* BODY COMP., FRAME	5.0	20	83515-KWH-970	COVER 'L' UTILITY BOX	1	1	1	1
* UTILITY BOX COMP.,		21	83520-KTC-900	COLLAR 'R' UTILITY BOX	1	1	1	1
(INC. RELATIVE PART)		22	83550-KWH-961	LOCK, SIDE COVER	1	1	1	1
		23	90101-KCC-940	BOLT, WASH 6X25	2	2	2	2
		24	90116-KCC-900	BOLT, FLANGE 8X97	1	1	1	1
		25	90117-KCC-900	BOLT, FLANGE 8X110	1	1	1	1
		26	90501-KC2-750	WASHER, REGULATOR	2	2	2	2
		27	91509-GE2-760	SCREW PAN 5X11.5	1	1	1	1
		28	93903-25220	SCREW, TAPPING 5X12	1	1	1	1
		29	94021-06000-0S	NUT, HEX. CAP 6 MM	2	2	2	2
		30	94030-08000	NUT HEX., 8 MM	2	2	2	2
		31	94111-08000	WASHER, SPRING 8MM	2	2	2	2
		32	95002-02070	CLIP, B7 TUBE	2	2	2	2
		33	95005-35170-20	TUBE, 3.5 X 170	-	-	1	1
		34	95701-06010-08	BOLT, FLANGE 6X10	1	1	1	1
		35	95701-06016-07	BOLT, FLANGE 6X16	2	2	2	2
		36	95701-08016-00	BOLT, FLANGE 8X16	4	4	4	4
		37	95701-10045-07	BOLT, FLANGE 10X45	2	2	2	2

**F - 26
TOOLS**

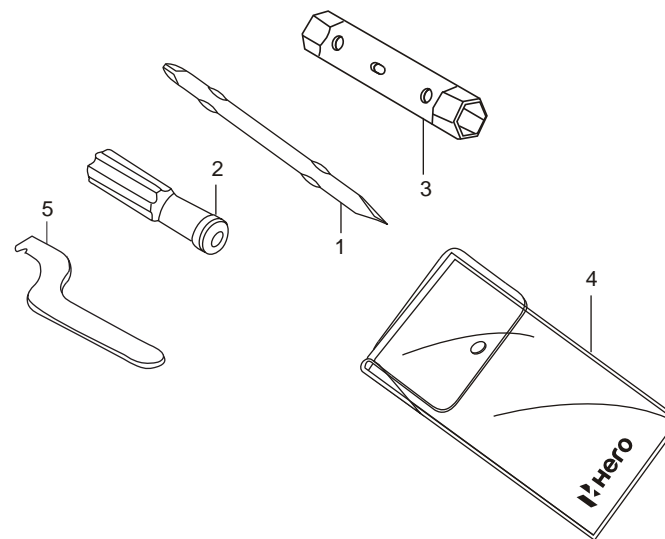

FR.

Service Item	F.R.T.	Ref. No.	Part No.	Description	Reqd. No. SPLENDOR PRO			
					DRUM			
					KICK		SELF	
					SPOKE	CAST	SPOKE	CAST
		1	89102-538-000	DRIVER, NO.2 PLUS,MINUS.....	1	1	1	1
		2	89103-538-000	GRIP.....	1	1	1	1
		3	89215-AAC-000	BOX WRENCH P16X14.....	1	1	1	1
		4	89216-AAD-H00	TOOL, BAG.....	1	1	1	1
		5	99007-45000	PIN SPANNER.....	1	1	1	1

F-27 STRIPES/MARKS

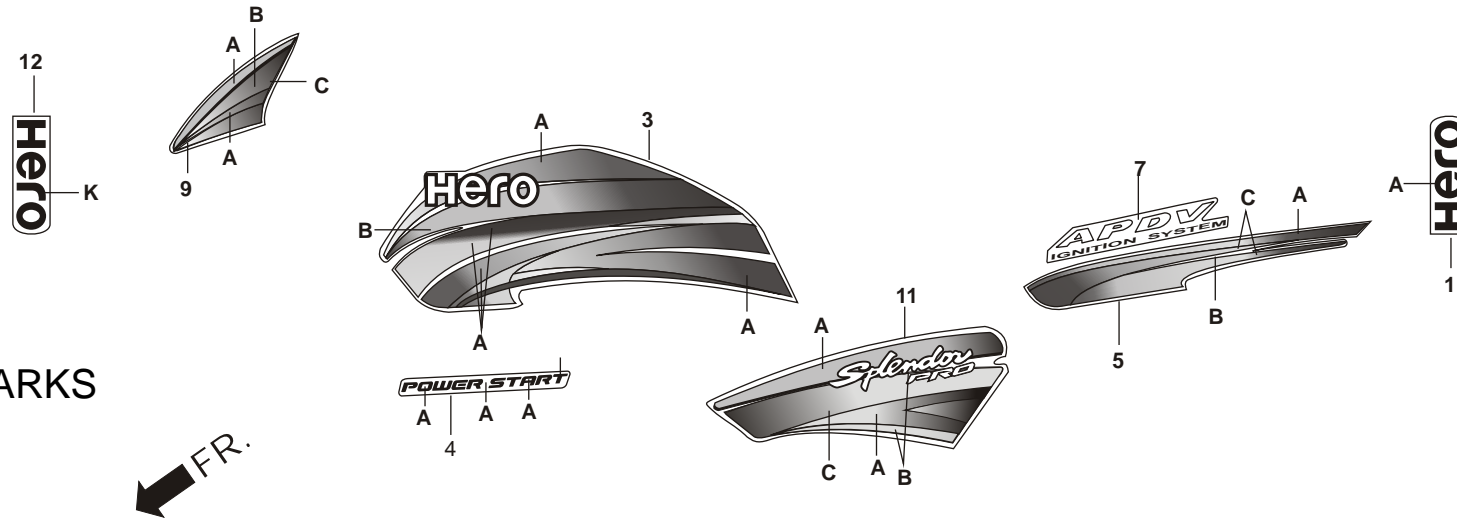

Service Item	F.R.T.	Ref. No.	Part No.	Description	Reqd. No. SPLENDOR PRO			
					DRUM			
					KICK		SELF	
SPOKE	CAST	SPOKE	CAST					
		1	77238-AAD-H70ZA	MARK CENTER RR COWL (TYPE-1).....	1	1	1	1
			77238-AAD-H70ZB	MARK CENTER RR COWL (TYPE-2).....	1	1	1	1

SPECIFIED COLOUR CHART FOR STRIPE MARK CENTER RR COWL

SPECIFIED COLOUR TYPE	A	MAIN BODY COLOUR
1	FORCE SILVER METALLIC (NH-411M)	BLACK (NH-1) TYPE-1
		BLACK (NH-1) TYPE-2
		CLOUD SILVER ME. (NH-35M)
		CANDY BLAZING RED (R-195C)
2	NH-1 BLACK	EXCELLENT BLUE ME. (PB-365M)
		HI-GRANITE BLUE ME. (PB-307M)
		PALACE MAROON ME. (R-308M)
		HEAVY GRAY ME. (NH-194M-U)

F-27 STRIPES/MARKS

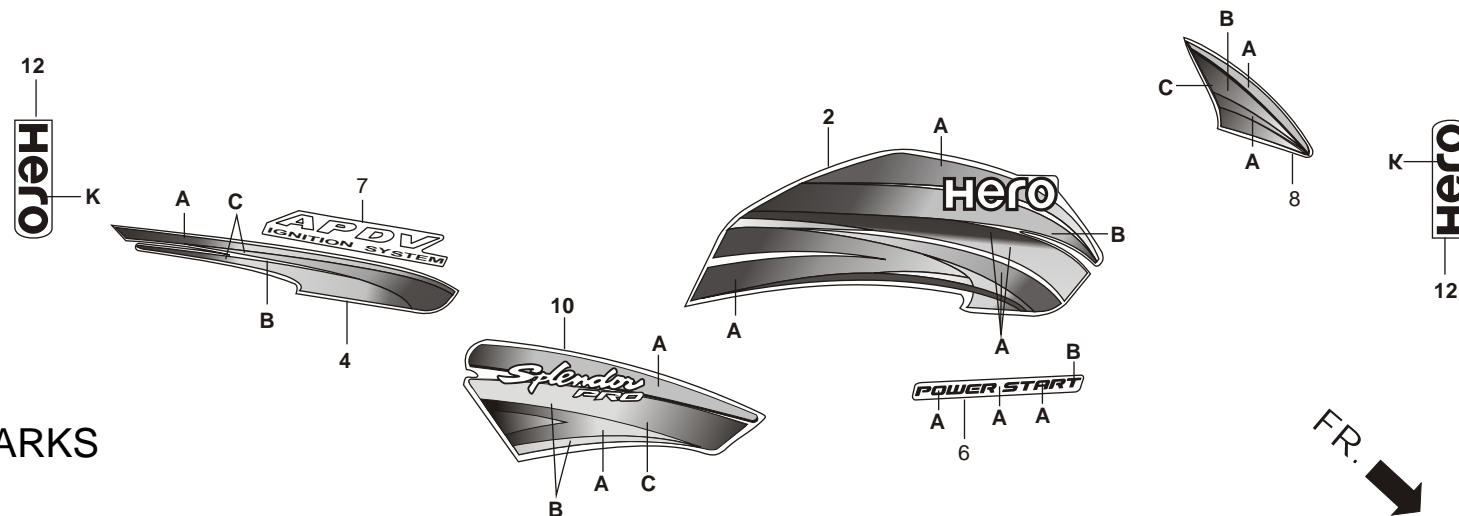

Service Item	F.R.T.	Ref. No.	Part No.	Description	Reqd. No. SPLENDOR PRO			
					DRUM			
					KICK		SELF	
					SPOKE	CAST	SPOKE	CAST
		2	86171-AAD-H70ZA	STRIPE R. FUEL TANK (TYPE-1).....	1	1	1	1
			86171-AAD-H70ZB	STRIPE R. FUEL TANK (TYPE-2).....	1	1	1	1
			86171-AAD-H70ZC	STRIPE R. FUEL TANK (TYPE-3).....	1	1	1	1
			86171-AAD-H70ZD	STRIPE R. FUEL TANK (TYPE-4).....	1	1	1	1
			86171-AAD-H70ZE	STRIPE R. FUEL TANK (TYPE-5).....	1	1	1	1
			86171-AAD-H70ZF	STRIPE R. FUEL TANK (TYPE-6).....	1	1	1	1
			86171-AAD-H70ZG	STRIPE R. FUEL TANK (TYPE-7).....	1	1	1	1
			86171-AAD-H70ZH	STRIPE R. FUEL TANK (TYPE-8).....	1	1	1	1

SPECIFIED COLOUR CHART FOR STRIPE, R. FUEL TANK

SPECIFIED COLOUR TYPE	A	B	E	MAIN BODY COLOUR
1	FORCE SILVER METALLIC (NH-411M)	ENDURANCE VICUET	NH-1 BLACK	BLACK (NH-1) TYPE-1
2	FORCE SILVER METALLIC (NH-411M)	LIGHT SILVER	NH-1 BLACK	BLACK (NH-1) TYPE-2
3	LIGHT SILVER	NASSAU BLUE METALLIC PB-112M-U	CLOUD SILVER ME NH-35M	CLOUD SILVER ME. (NH-35M)
4	GOLD METALIC	PERSIHMON ORANGE	CANDY BLAZING RED (R-195C)	CANDY BLAZING RED (R-195C)
5	FORCE SILVER METALLIC (NH-411M)	ACE BLUE	EXCELLENT BLUE	EXCELLENT BLUE ME. (PB-365M)
6	FORCE SILVER METALLIC (NH-411M)	RED-1	HI-GRANITE BLUE	HI-GRANITE BLUE ME. (PB-307M)
7	SPARKING SILVER METALLIC (NH-295)	RED-1	PALACE MAROON	PALACE MAROON ME. (R-308M)
8	FORCE SILVER METALLIC (NH-411M)	LEAF GREEN METALLIC GY-141M	HEAVY GRAY	HEAVY GRAY ME. (NH-194M-U)

F-27 STRIPES/MARKS

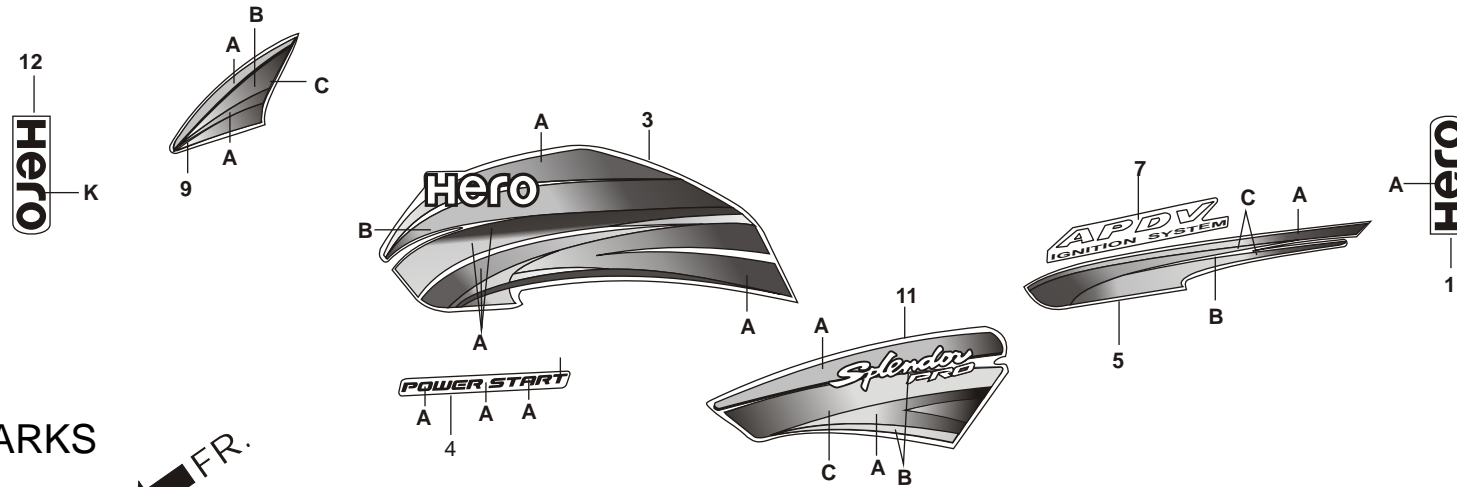

Service Item	F.R.T.	Ref. No.	Part No.	Description	Reqd. No. SPLENDOR PRO			
					DRUM			
					KICK		SELF	
		SPOKE	CAST	SPOKE	CAST			
		3	86172-AAD-H70ZA	STRIPE L. FUEL TANK (TYPE-1).....	1	1	1	1
			86172-AAD-H70ZB	STRIPE L. FUEL TANK (TYPE-2).....	1	1	1	1
			86172-AAD-H70ZC	STRIPE L. FUEL TANK (TYPE-3).....	1	1	1	1
			86172-AAD-H70ZD	STRIPE L. FUEL TANK (TYPE-4).....	1	1	1	1
			86172-AAD-H70ZE	STRIPE L. FUEL TANK (TYPE-5).....	1	1	1	1
			86172-AAD-H70ZF	STRIPE L. FUEL TANK (TYPE-6).....	1	1	1	1
			86172-AAD-H70ZG	STRIPE L. FUEL TANK (TYPE-7).....	1	1	1	1
			86172-AAD-H70ZH	STRIPE L. FUEL TANK (TYPE-8).....	1	1	1	1

SPECIFIED COLOUR CHART FOR STRIPE, L. FUEL TANK

SPECIFIED COLOUR TYPE	A	B	E	MAIN BODY COLOUR
1	FORCE SILVER METALLIC (NH-411M)	ENDURANCE VICUET	NH-1 BLACK	BLACK (NH-1) TYPE-1
2	FORCE SILVER METALLIC (NH-411M)	LIGHT SILVER	NH-1 BLACK	BLACK (NH-1) TYPE-2
3	LIGHT SILVER	NASSAU BLUE METALLIC PB-112M-U	CLOUD SILVER ME NH-35M	CLOUD SILVER ME. (NH-35M)
4	GOLD METALIC	PERSIHMON ORANGE	CANDY BLAZING RED (R-195C)	CANDY BLAZING RED (R-195C)
5	FORCE SILVER METALLIC (NH-411M)	ACE BLUE	EXCELLENT BLUE	EXCELLENT BLUE ME. (PB-365M)
6	FORCE SILVER METALLIC (NH-411M)	RED-1	HI-GRANITE BLUE	HI-GRANITE BLUE ME. (PB-307M)
7	SPARKING SILVER METALLIC (NH-295)	RED-1	PALACE MAROON	PALACE MAROON ME. (R-308M)
8	FORCE SILVER METALLIC (NH-411M)	LEAF GREEN METALLIC GY-141M	HEAVY GRAY	HEAVY GRAY ME. (NH-194M-U)

F-27 STRIPES/MARKS

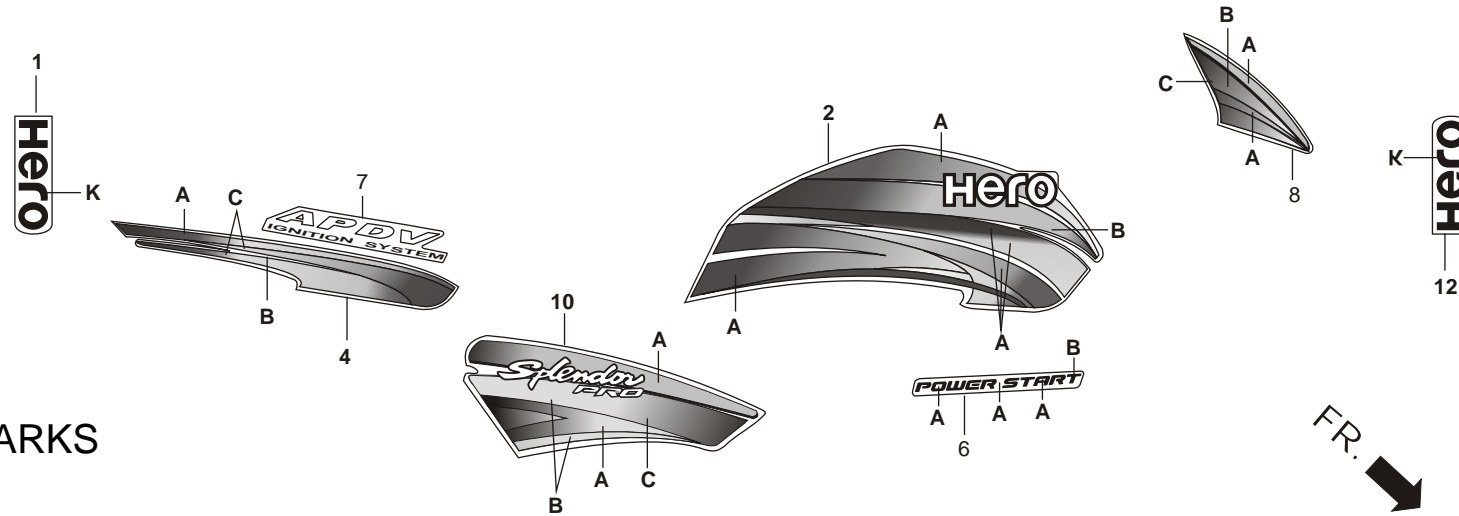

Service Item	F.R.T.	Ref. No.	Part No.	Description	Reqd. No. SPLENDOR PRO			
					DRUM			
					KICK		SELF	
		SPOKE	CAST	SPOKE	CAST			
		4	86771-AAD-H70ZA	STRIPE R SIDE COWL (TYPE-1)	1	1	1	1
			86771-AAD-H70ZB	STRIPE R SIDE COWL (TYPE-2)	1	1	1	1
			86771-AAD-H70ZC	STRIPE R SIDE COWL (TYPE-3)	1	1	1	1
			86771-AAD-H70ZD	STRIPE R SIDE COWL (TYPE-4)	1	1	1	1
			86771-AAD-H70ZE	STRIPE R SIDE COWL (TYPE-5)	1	1	1	1
			86771-AAD-H70ZF	STRIPE R SIDE COWL (TYPE-6)	1	1	1	1
			86771-AAD-H70ZG	STRIPE R SIDE COWL (TYPE-7)	1	1	1	1
			86771-AAD-H70ZH	STRIPE R SIDE COWL (TYPE-8)	1	1	1	1

SPECIFIED COLOUR CHART FOR STRIPE MARK UTILITY BOX COVER

SPECIFIED COLOUR TYPE	A	B	C	E	MAIN BODY COLOUR
1	FORCE SILVER METALLIC (NH-411M)	ENDURANCE VICUET	FORCE SILVER METALLIC (NH-411M)	NH-1 BLACK	BLACK (NH-1) TYPE-1
2	FORCE SILVER METALLIC (NH-411M)	LIGHT SILVER	FORCE SILVER METALLIC (NH-411M)	NH-1 BLACK	BLACK (NH-1) TYPE-2
3	LIGHT SILVER	NASSAU BLUE METALLIC PB-112M-U	NH-1 BLACK	CLOUD SILVER ME NH-35M	CLOUD SILVER ME. (NH-35M)
4	GOLD METALIC	PERSIHMOM ORANGE	VARIANT BROWN METALLIC	CANDY BLAZING RED (R-195C)	CANDY BLAZING RED (R-195C)
5	FORCE SILVER METALLIC (NH-411M)	ACE BLUE	FORCE SILVER METALLIC (NH-411M)	EXCELLENT BLUE	EXCELLENT BLUE ME. (PB-365M)
6	FORCE SILVER METALLIC (NH-411M)	RED-1	SPARKING SILVER METALLIC (NH-295)	HI-GRANITE BLUE	HI-GRANITE BLUE ME. (PB-307M)
7	SPARKING SILVER METALLIC (NH-295)	RED-1	SPARKING SILVER METALLIC (NH-295)	PALACE MAROON	PALACE MAROON ME. (R-308M)
8	FORCE SILVER METALLIC (NH-411M)	LEAF GREEN METALLIC GY-141M	FORCE SILVER METALLIC (NH-411M)	HEAVY GRAY	HEAVY GRAY ME. (NH-194M-U)

F-27 STRIPES/MARKS

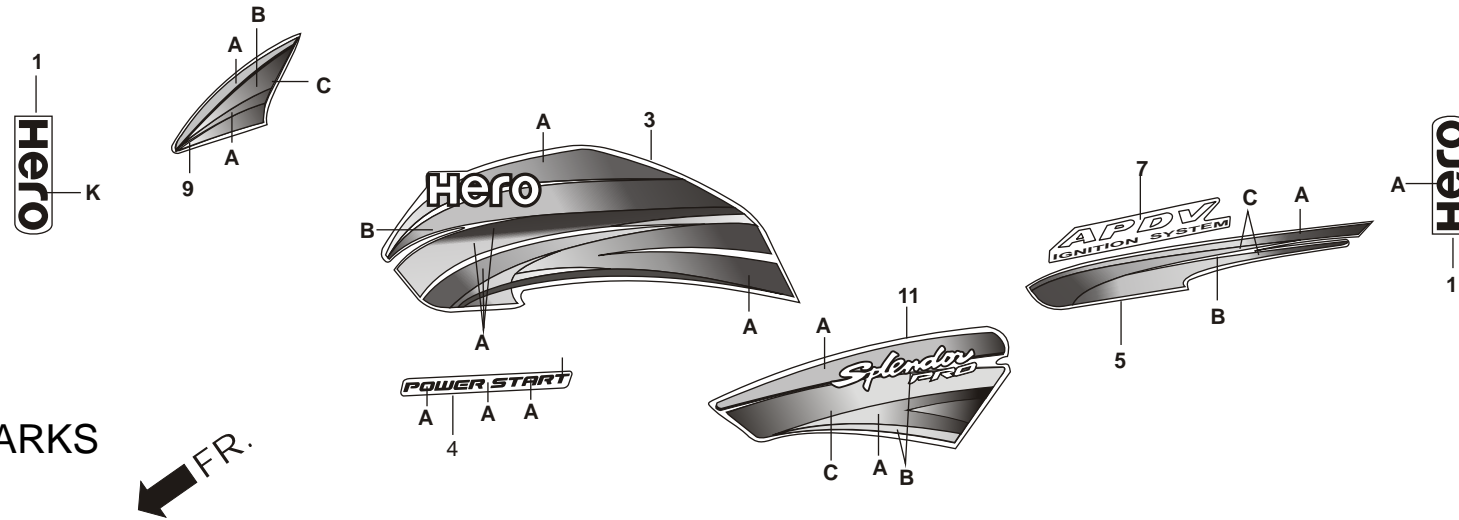

Service Item	F.R.T.	Ref. No.	Part No.	Description	Reqd. No. SPLENDOR PRO			
					DRUM			
					KICK		SELF	
	SPOKE	CAST	SPOKE	CAST				
		5	86772-AAD-H70ZA	STRIPE L. SIDE COWL (TYPE-1).....	1	1	1	1
			86772-AAD-H70ZB	STRIPE L. SIDE COWL (TYPE-2).....	1	1	1	1
			86772-AAD-H70ZC	STRIPE L. SIDE COWL (TYPE-3).....	1	1	1	1
			86772-AAD-H70ZD	STRIPE L. SIDE COWL (TYPE-4).....	1	1	1	1
			86772-AAD-H70ZE	STRIPE L. SIDE COWL (TYPE-5).....	1	1	1	1
			86772-AAD-H70ZF	STRIPE L. SIDE COWL (TYPE-6).....	1	1	1	1
			86772-AAD-H70ZG	STRIPE L. SIDE COWL (TYPE-7).....	1	1	1	1
			86772-AAD-H70ZH	STRIPE L. SIDE COWL (TYPE-8).....	1	1	1	1

SPECIFIED COLOUR CHART FOR STRIPE, R. SIDE COWL

SPECIFIED COLOUR TYPE	A	B	C	E	MAIN BODY COLOUR
1	FORCE SILVER METALLIC (NH-411M)	ENDURANCE VICUET	FORCE SILVER METALLIC (NH-411M)	NH-1 BLACK	BLACK (NH-1) TYPE-1
2	FORCE SILVER METALLIC (NH-411M)	LIGHT SILVER	FORCE SILVER METALLIC (NH-411M)	NH-1 BLACK	BLACK (NH-1) TYPE-2
3	LIGHT SILVER	NASSAU BLUE METALLIC PB-112M-U	NH-1 BLACK	CLOUD SILVER ME NH-35M	CLOUD SILVER ME. (NH-35M)
4	GOLD METALIC	PERSIHMOM ORANGE	VARIANT BROWN METALLIC	CANDY BLAZING RED (R-195C)	CANDY BLAZING RED (R-195C)
5	FORCE SILVER METALLIC (NH-411M)	ACE BLUE	FORCE SILVER METALLIC (NH-411M)	EXCELLENT BLUE	EXCELLENT BLUE ME. (PB-365M)
6	FORCE SILVER METALLIC (NH-411M)	RED-1	SPARKING SILVER METALLIC (NH-295)	HI-GRANITE BLUE	HI-GRANITE BLUE ME. (PB-307M)
7	SPARKING SILVER METALLIC (NH-295)	RED-1	SPARKING SILVER METALLIC (NH-295)	PALACE MAROON	PALACE MAROON ME. (R-308M)
8	FORCE SILVER METALLIC (NH-411M)	LEAF GREEN METALLIC GY-141M	FORCE SILVER METALLIC (NH-411M)	HEAVY GRAY	HEAVY GRAY ME. (NH-194M-U)

**F-27
STRIPES/MARKS**

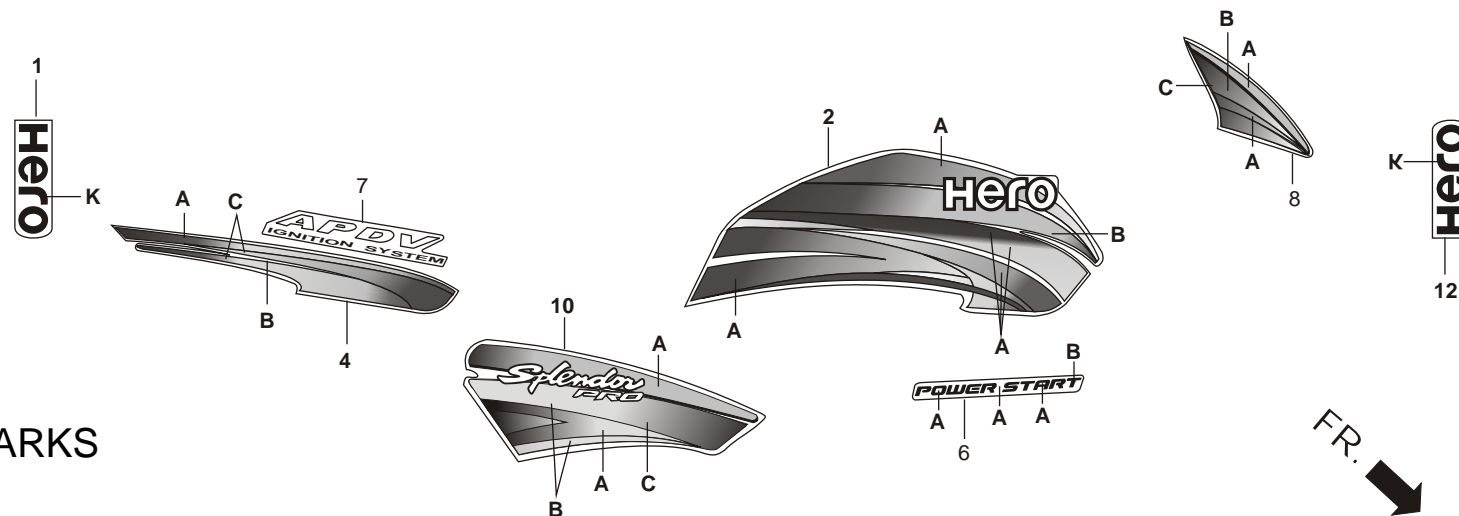

Service Item	F.R.T.	Ref. No.	Part No.	Description	Reqd. No. SPLENDOR PRO			
					DRUM			
					KICK		SELF	
SPOKE	CAST	SPOKE	CAST					
		6	86511-KVH-780	MARK UTILITY BOX COVER (TYPE-1).....	1	1	1	1

SPECIFIED COLOUR CHART FOR STRIPE MARK UTILITY BOX COVER

SPECIFIED COLOUR TYPE	A	B	MAIN BODY COLOUR
1	MAT BLACK	FORCE SILVER ME. NH-411M	BLACK (NH-1) TYPE-1
			BLACK (NH-1) TYPE-2
			CLOUD SILVER ME. (NH-35M)
			CANDY BLAZING RED (R-195C)
			EXCELLENT BLUE ME. (PB-365M)
			HI-GRANITE BLUE ME. (PB-307M)
			PALACE MAROON ME. (R-308M)
			HEAVY GRAY ME. (NH-194M-U)

F-27 STRIPES/MARKS

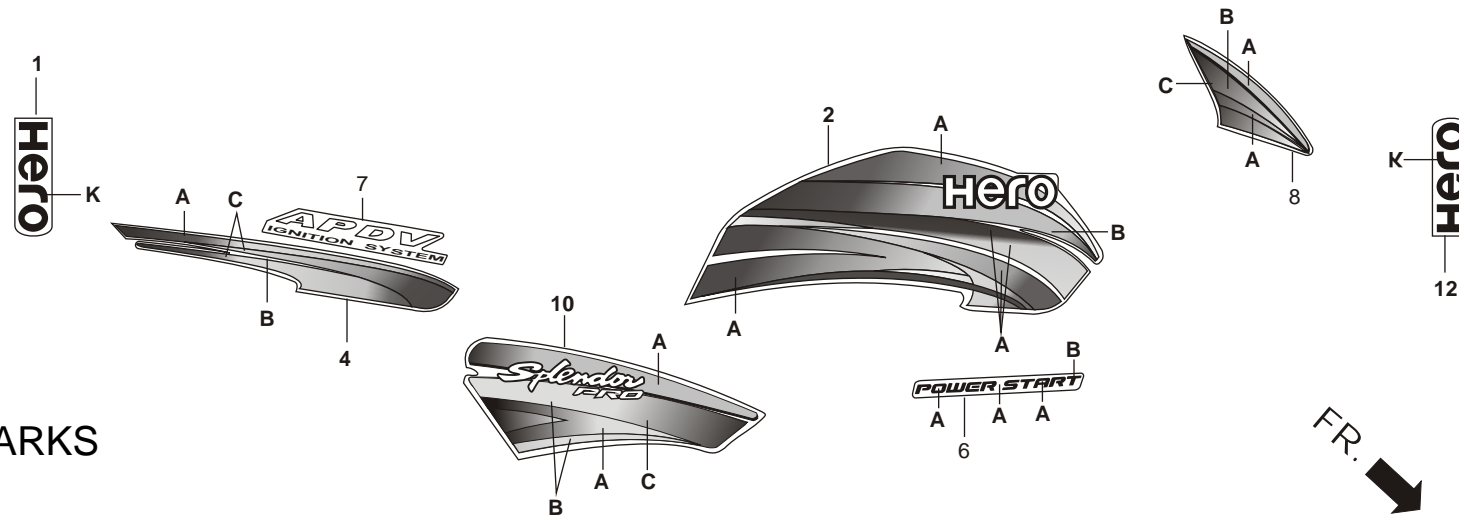

Service Item	F.R.T.	Ref. No.	Part No.	Description	Reqd. No. SPLENDOR PRO			
					DRUM			
					KICK		SELF	
		SPOKE	CAST	SPOKE	CAST			
		7	86773-KWH-970ZA	MARK, APDV (TYPE-1).....	1	1	1	1
			86773-KWH-970ZB	MARK, APDV (TYPE-2).....	1	1	1	1

SPECIFIED COLOUR CHART FOR STRIPE MARK APDV

SPECIFIED COLOUR TYPE	A	B	C	F	MAIN BODY COLOUR
1	BLACK NH-1	LIGHT SILVER	FORCE SILVER ME. NH-411M	BLACK NH-1	BLACK (NH-1) TYPE-1
1	BLACK NH-1	LIGHT SILVER	FORCE SILVER ME. NH-411M	BLACK NH-1	BLACK (NH-1) TYPE-2
2	BLACK NH-1	ENDURANCE VIOLET	FORCE SILVER ME. NH-411M	BLACK NH-1	CLOUD SILVER ME. (NH-35M)
1	BLACK NH-1	LIGHT SILVER	FORCE SILVER ME. NH-411M	BLACK NH-1	CANDY BLAZING RED (R-195C)
1	BLACK NH-1	LIGHT SILVER	FORCE SILVER ME. NH-411M	BLACK NH-1	EXCELLENT BLUE ME. (PB-365M)
1	BLACK NH-1	LIGHT SILVER	FORCE SILVER ME. NH-411M	BLACK NH-1	HI-GRANITE BLUE ME. (PB-307M)
1	BLACK NH-1	LIGHT SILVER	FORCE SILVER ME. NH-411M	BLACK NH-1	PALACE MAROON ME. (R-308M)
1	BLACK NH-1	LIGHT SILVER	FORCE SILVER ME. NH-411M	BLACK NH-1	HEAVY GRAY ME. (NH-194M-U)

F-27 STRIPES/MARKS

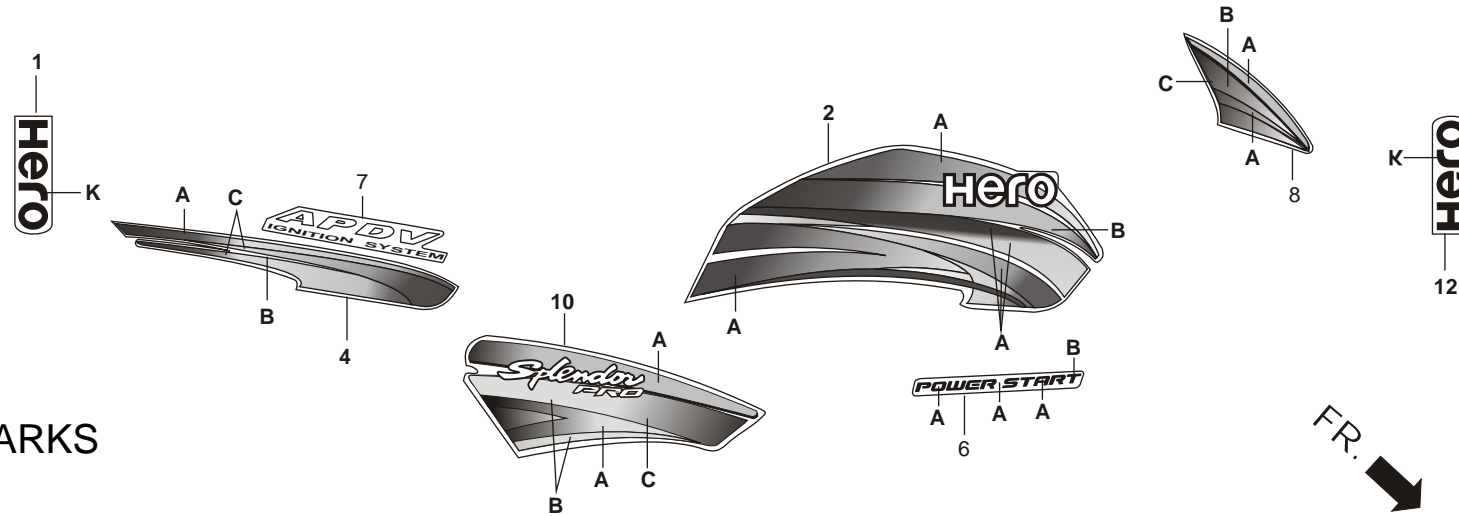

Service Item	F.R.T.	Ref. No.	Part No.	Description	Reqd. No. SPLENDOR PRO			
					DRUM			
					KICK		SELF	
		SPOKE	CAST	SPOKE	CAST			
		8	86831-AAD-H70ZA	STRIPE R FR. VISOR (TYPE-1).....	1	1	1	1
			86831-AAD-H70ZB	STRIPE R FR. VISOR (TYPE-2).....	1	1	1	1
			86831-AAD-H70ZC	STRIPE R FR. VISOR (TYPE-3).....	1	1	1	1
			86831-AAD-H70ZD	STRIPE R FR. VISOR (TYPE-4).....	1	1	1	1
			86831-AAD-H70ZE	STRIPE R FR. VISOR (TYPE-5).....	1	1	1	1
			86831-AAD-H70ZF	STRIPE R FR. VISOR (TYPE-6).....	1	1	1	1
			86831-AAD-H70ZG	STRIPE R FR. VISOR (TYPE-7).....	1	1	1	1
			86831-AAD-H70ZH	STRIPE R FR. VISOR (TYPE-8).....	1	1	1	1

SPECIFIED COLOUR CHART FOR STRIPE, R. FR. VISOR

SPECIFIED COLOUR TYPE	A	B	C	E	MAIN BODY COLOUR
1	FORCE SILVER METALLIC (NH-411M)	ENDURANCE VICUET	FORCE SILVER METALLIC (NH-411M)	NH-1 BLACK	BLACK (NH-1) TYPE-1
2	FORCE SILVER METALLIC (NH-411M)	LIGHT SILVER	FORCE SILVER METALLIC (NH-411M)	NH-1 BLACK	BLACK (NH-1) TYPE-2
3	LIGHT SILVER	NASSAU BLUE METALLIC PB-112M-U	NH-1 BLACK	CLOUD SILVER ME NH-35M	CLOUD SILVER ME. (NH-35M)
4	GOLD METALIC	PERSIHMOM ORANGE	VARIANT BROWN METALLIC	CANDY BLAZING RED (R-195C)	CANDY BLAZING RED (R-195C)
5	FORCE SILVER METALLIC (NH-411M)	ACE BLUE	FORCE SILVER METALLIC (NH-411M)	EXCELLENT BLUE	EXCELLENT BLUE ME. (PB-365M)
6	FORCE SILVER METALLIC (NH-411M)	RED-1	SPARKING SILVER METALLIC (NH-295)	HI-GRANITE BLUE	HI-GRANITE BLUE ME. (PB-307M)
7	SPARKING SILVER METALLIC (NH-295)	RED-1	SPARKING SILVER METALLIC (NH-295)	PALACE MAROON	PALACE MAROON ME. (R-308M)
8	FORCE SILVER METALLIC (NH-411M)	LEAF GREEN METALLIC GY-141M	FORCE SILVER METALLIC (NH-411M)	HEAVY GRAY	HEAVY GRAY ME. (NH-194M-U)

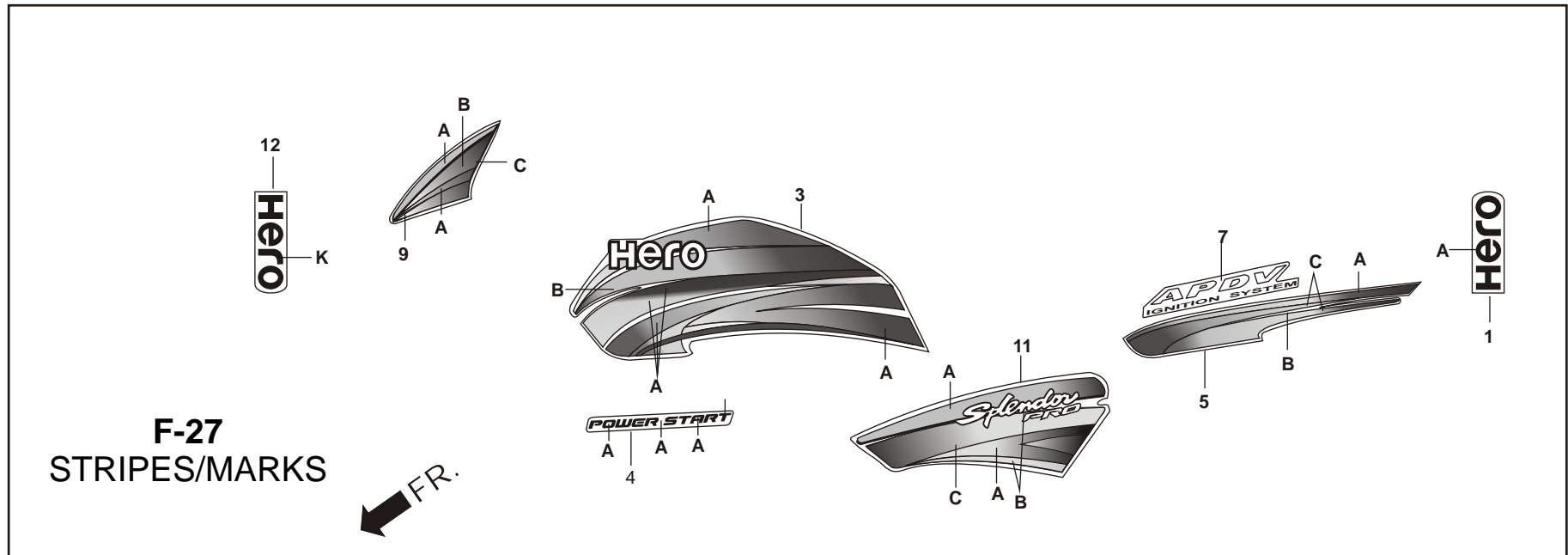

**F-27
STRIPES/MARKS**

Service Item	F.R.T.	Ref. No.	Part No.	Description	Reqd. No. SPLENDOR PRO			
					DRUM			
					KICK		SELF	
		SPOKE	CAST	SPOKE	CAST			
		9	86832-AAD-H70ZA	STRIPE L. FR. VISIOR (TYPE-1).....	1	1	1	1
			86832-AAD-H70ZB	STRIPE L. FR. VISIOR (TYPE-2).....	1	1	1	1
			86832-AAD-H70ZC	STRIPE L. FR. VISIOR (TYPE-3).....	1	1	1	1
			86832-AAD-H70ZD	STRIPE L. FR. VISIOR (TYPE-4).....	1	1	1	1
			86832-AAD-H70ZE	STRIPE L. FR. VISIOR (TYPE-5).....	1	1	1	1
			86832-AAD-H70ZF	STRIPE L. FR. VISIOR (TYPE-6).....	1	1	1	1
			86832-AAD-H70ZG	STRIPE L. FR. VISIOR (TYPE-7).....	1	1	1	1
			86832-AAD-H70ZH	STRIPE L. FR. VISIOR (TYPE-8).....	1	1	1	1

SPECIFIED COLOUR CHART FOR STRIPE, L. FR. VISOR					
SPECIFIED COLOUR TYPE	A	B	C	E	MAIN BODY COLOUR
1	FORCE SILVER METALLIC (NH-411M)	ENDURANCE VICUET	FORCE SILVER METALLIC (NH-411M)	NH-1 BLACK	BLACK (NH-1) TYPE-1
2	FORCE SILVER METALLIC (NH-411M)	LIGHT SILVER	FORCE SILVER METALLIC (NH-411M)	NH-1 BLACK	BLACK (NH-1) TYPE-2
3	LIGHT SILVER	NASSAU BLUE METALLIC PB-112M-U	NH-1 BLACK	CLOUD SILVER ME NH-35M	CLOUD SILVER ME. (NH-35M)
4	GOLD METALIC	PERSIHMOM ORANGE	VARIANT BROWN METALLIC	CANDY BLAZING RED (R-195C)	CANDY BLAZING RED (R-195C)
5	FORCE SILVER METALLIC (NH-411M)	ACE BLUE	FORCE SILVER METALLIC (NH-411M)	EXCELLENT BLUE	EXCELLENT BLUE ME. (PB-365M)
6	FORCE SILVER METALLIC (NH-411M)	RED-1	SPARKING SILVER METALLIC (NH-295)	HI-GRANITE BLUE	HI-GRANITE BLUE ME. (PB-307M)
7	SPARKING SILVER METALLIC (NH-295)	RED-1	SPARKING SILVER METALLIC (NH-295)	PALACE MAROON	PALACE MAROON ME. (R-308M)
8	FORCE SILVER METALLIC (NH-411M)	LEAF GREEN METALLIC GY-141M	FORCE SILVER METALLIC (NH-411M)	HEAVY GRAY	HEAVY GRAY ME. (NH-194M-U)

F-27 STRIPES/MARKS

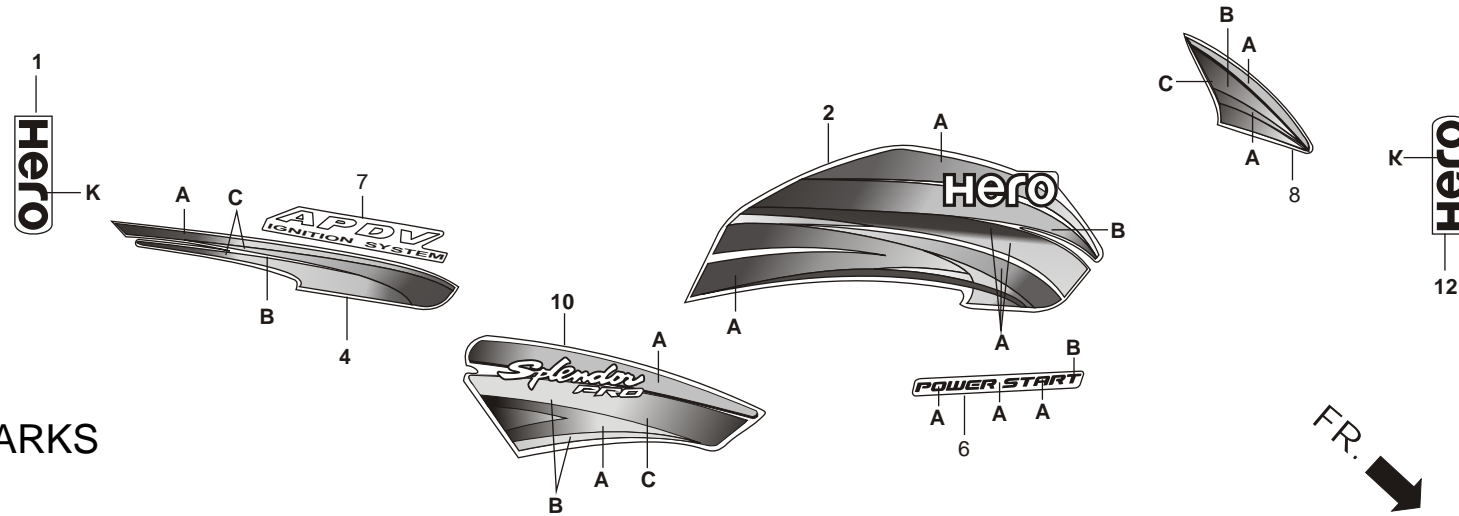

Service Item	F.R.T.	Ref. No.	Part No.	Description	Reqd. No. SPLENDOR PRO			
					DRUM			
					KICK		SELF	
					SPOKE	CAST	SPOKE	CAST
		10	86833-AAD-H70ZA	STRIPE R. SIDE COVER (TYPE-1).....	1	1	1	1
			86833-AAD-H70ZB	STRIPE R. SIDE COVER (TYPE-2).....	1	1	1	1
			86833-AAD-H70ZC	STRIPE R. SIDE COVER (TYPE-3).....	1	1	1	1
			86833-AAD-H70ZD	STRIPE R. SIDE COVER (TYPE-4).....	1	1	1	1
			86833-AAD-H70ZE	STRIPE R. SIDE COVER (TYPE-5).....	1	1	1	1
			86833-AAD-H70ZF	STRIPE R. SIDE COVER (TYPE-6).....	1	1	1	1
			86833-AAD-H70ZG	STRIPE R. SIDE COVER (TYPE-7).....	1	1	1	1
			86833-AAD-H70ZH	STRIPE R. SIDE COVER (TYPE-8).....	1	1	1	1

SPECIFIED COLOUR CHART FOR STRIPE, R. SIDE COVER

SPECIFIED COLOUR TYPE	A	B	C	E	MAIN BODY COLOUR
1	FORCE SILVER METALLIC (NH-411M)	LIGHT SILVER	FORCE SILVER ME. NH-411M	NH-1 BLACK	BLACK (NH-1) TYPE-1
2	FORCE SILVER METALLIC (NH-411M)	ENDURANCE VIOLET	FORCE SILVER ME. NH-411M	NH-1 BLACK	BLACK (NH-1) TYPE-2
3	LIGHT SILVER	NASSAU BLUE ME.-U PB-112M-U	LIGHT SILVER	CLOUD SILVER ME NH-35M	CLOUD SILVER ME. (NH-35M)
4	GOLD METALIC	PERSIMMON ORANGE	GOLD ME.	CANDY BLAZING RED (R-195C)	CANDY BLAZING RED (R-195C)
5	FORCE SILVER METALLIC (NH-411M)	ACE BLUE	FORCE SILVER ME. NH-411M	EXCELLENT BLUE	EXCELLENT BLUE ME. (PB-365M)
6	FORCE SILVER METALLIC (NH-411M)	RED-1	FORCE SILVER ME. NH-411M	HI-GRANITE BLUE	HI-GRANITE BLUE ME. (PB-307M)
7	SPARKLING SILVER METALLIC (NH-295)	RED-1	SPARKLING SILVER ME. NH-295M	PALACE MAROON	PALACE MAROON ME. (R-308M)
8	FORCE SILVER METALLIC (NH-411M)	LEAF GREEN ME. GY-141M	FORCE SILVER ME. NH-411M	HEAVY GRAY	HEAVY GRAY ME. (NH-194M-U)

**F-27
STRIPES/MARKS**

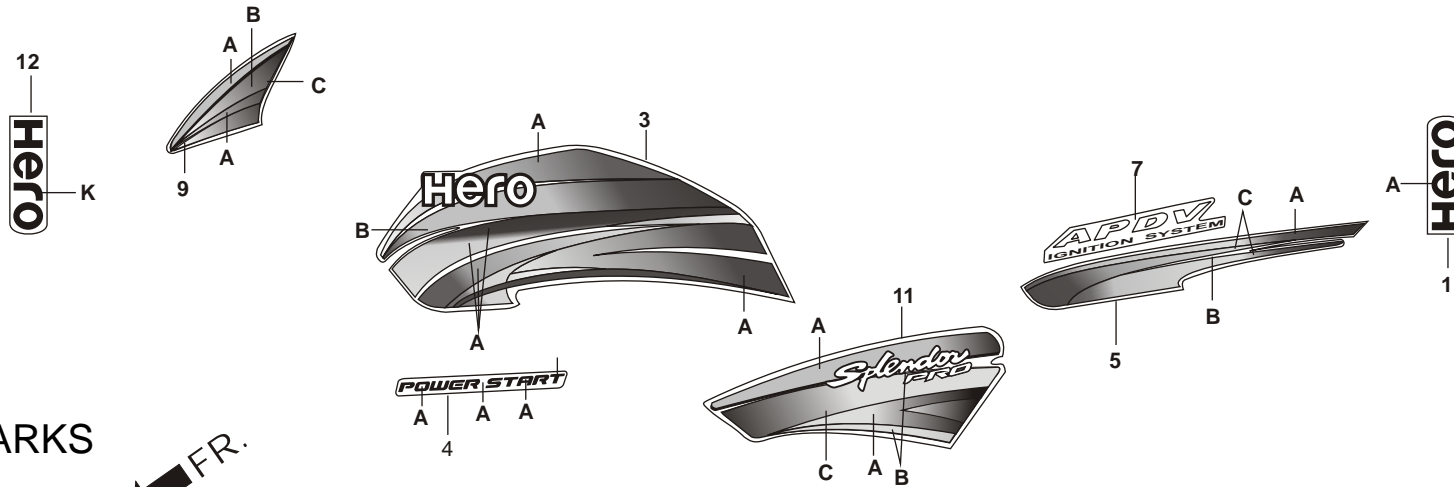

Service Item	F.R.T.	Ref. No.	Part No.	Description	Reqd. No. SPLENDOR PRO			
					DRUM			
					KICK		SELF	
		SPOKE	CAST	SPOKE	CAST			
		11	86834-AAD-H70ZA	STRIPE L. SIDE COVER (TYPE-1).....	1	1	1	1
			86834-AAD-H70ZB	STRIPE L. SIDE COVER (TYPE-2).....	1	1	1	1
			86834-AAD-H70ZC	STRIPE L. SIDE COVER (TYPE-3).....	1	1	1	1
			86834-AAD-H70ZD	STRIPE L. SIDE COVER (TYPE-4).....	1	1	1	1
			86834-AAD-H70ZE	STRIPE L. SIDE COVER (TYPE-5).....	1	1	1	1
			86834-AAD-H70ZF	STRIPE L. SIDE COVER (TYPE-6).....	1	1	1	1
			86834-AAD-H70ZG	STRIPE L. SIDE COVER (TYPE-7).....	1	1	1	1
			86834-AAD-H70ZH	STRIPE L. SIDE COVER (TYPE-8).....	1	1	1	1

SPECIFIED COLOUR CHART FOR STRIPE, L. SIDE COVER

SPECIFIED COLOUR TYPE	A	B	C	E	MAIN BODY COLOUR
1	FORCE SILVER METALLIC (NH-411M)	LIGHT SILVER	FORCE SILVER ME. NH-411M	NH-1 BLACK	BLACK (NH-1) TYPE-1
2	FORCE SILVER METALLIC (NH-411M)	ENDURANCE VIOLET	FORCE SILVER ME. NH-411M	NH-1 BLACK	BLACK (NH-1) TYPE-2
3	LIGHT SILVER	NASSAU BLUE ME.-U PB-112M-U	LIGHT SILVER	CLOUD SILVER ME NH-35M	CLOUD SILVER ME. (NH-35M)
4	GOLD METALIC	PERSIMMON ORANGE	GOLD ME.	CANDY BLAZING RED (R-195C)	CANDY BLAZING RED (R-195C)
5	FORCE SILVER METALLIC (NH-411M)	ACE BLUE	FORCE SILVER ME. NH-411M	EXCELLENT BLUE	EXCELLENT BLUE ME. (PB-365M)
6	FORCE SILVER METALLIC (NH-411M)	RED-1	FORCE SILVER ME. NH-411M	HI-GRANITE BLUE	HI-GRANITE BLUE ME. (PB-307M)
7	SPARKLING SILVER METALLIC (NH-295)	RED-1	SPARKLING SILVER ME. NH-295M	PALACE MAROON	PALACE MAROON ME. (R-308M)
8	FORCE SILVER METALLIC (NH-411M)	LEAF GREEN ME. GY-141M	FORCE SILVER ME. NH-411M	HEAVY GRAY	HEAVY GRAY ME. (NH-194M-U)

**F-27
STRIPES/MARKS**

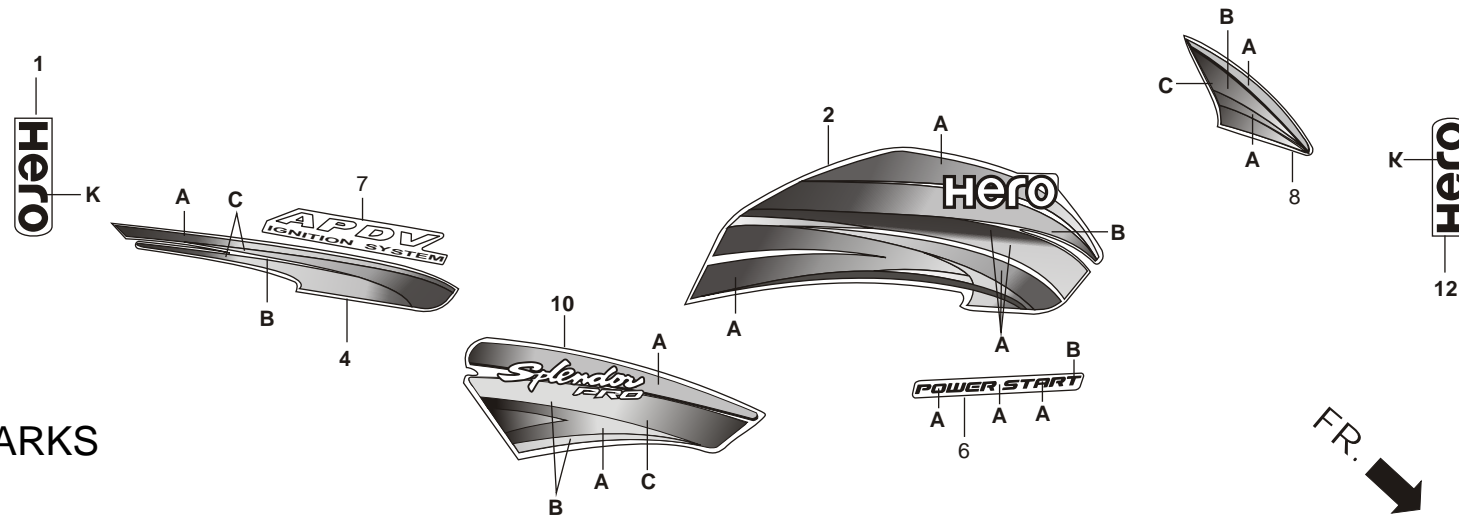

Service Item	F.R.T.	Ref. No.	Part No.	Description	Reqd. No. SPLENDOR PRO			
					DRUM			
					KICK		SELF	
SPOKE	CAST	SPOKE	CAST					
		12	86836-AAD-H70ZA	STRIPE FR. VISIOR (TYPE-1).....	1	1	1	1
			86836-AAD-H70ZB	STRIPE FR. VISIOR (TYPE-2).....	1	1	1	1

SPECIFIED COLOUR CHART FOR STRIPE, FR. VISIOR

SPECIFIED COLOUR TYPE	A	MAIN BODY COLOUR
1	FORCE SILVER METALLIC (NH-411M)	BLACK (NH-1) TYPE-1
		BLACK (NH-1) TYPE-2
		CLOUD SILVER ME. (NH-35M)
		CANDY BLAZING RED (R-195C)
2	BLACK NH-1	EXCELLENT BLUE ME. (PB-365M)
		HI-GRANITE BLUE ME. (PB-307M)
		PALACE MAROON ME. (R-308M)
		HEAVY GRAY ME. (NH-194M-U)

F - 28
GUARD ENGINE

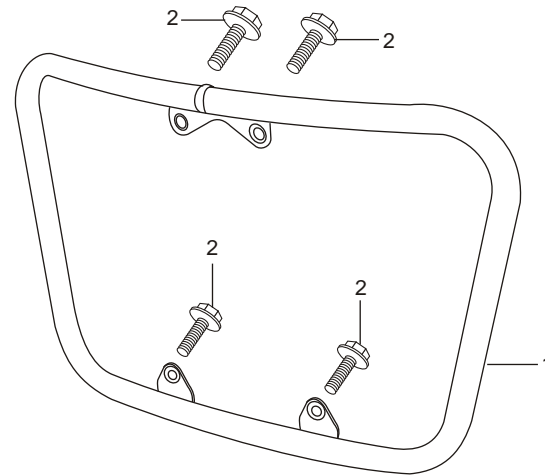

FR.

Service Item	F.R.T.	Ref. No.	Part No.	Description	Reqd. No. SPLENDOR PRO			
					DRUM			
					KICK		SELF	
					SPOKE	CAST	SPOKE	CAST
* GUARD ENGINE		1	50803-KWH-760	GUARD, ENGINE	1	1	1	1
		2	95701-08016-00	BOLT, FLANGE 8X16	4	4	4	4

F - 29
GUARD SARI

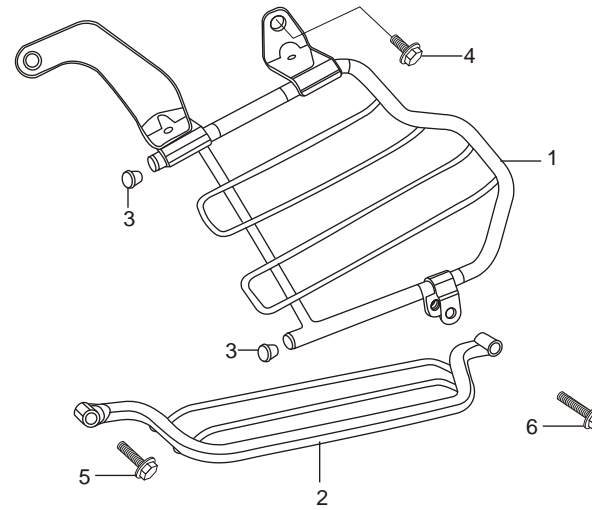

Service Item	F.R.T.	Ref. No.	Part No.	Description	Reqd. No. SPLENDOR PRO			
					DRUM			
					KICK		SELF	
SPOKE	CAST	SPOKE	CAST					
* GUARD SARI.....		1	51103-KWH-970	GUARD, SAREE.....	1	1	1	1
		2	51104-KST-940	STEP, WOMEN.....	1	1	1	1
		3	51106-KCC-900	CAP, GUARD SARI	2	2	2	2
		4	95701-08016-00	BOLT, FLANGE 8X16	1	1	1	1
		5	95701-08028-00	BOLT, FLANGE 8X28	1	1	1	1
		6	95701-08035-00	BOLT, FLANGE 8X35	1	1	1	1

**F - 30
MARK/CAUTION**

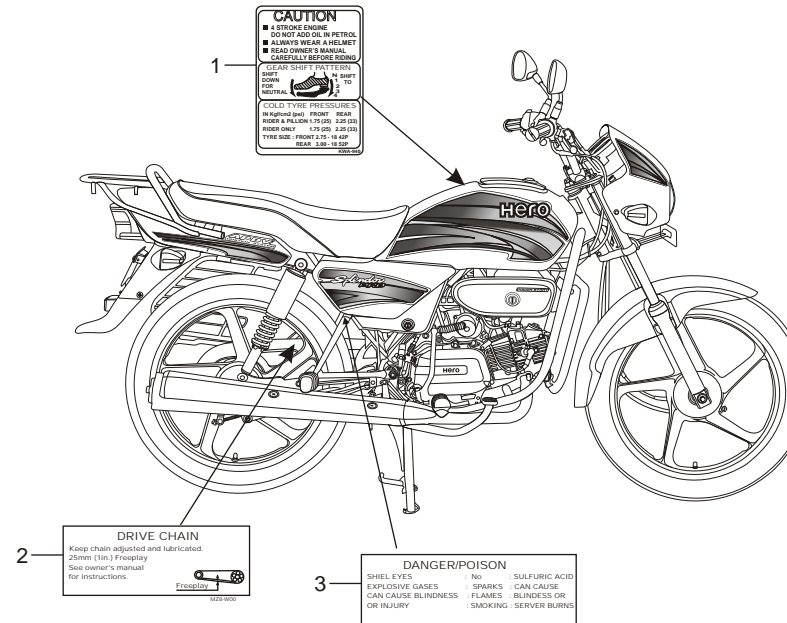

Service Item	F.R.T.	Ref. No.	Part No.	Description	Reqd. No. SPLENDOR PRO			
					DRUM			
					KICK		SELF	
SPOKE	CAST	SPOKE	CAST					
		1	87501-AAE-H20	MARK, CAUTION	1	1	-	-
		2	87507-MZ8-W00	LABEL DRIVE CHAIN.....	1	1	-	-
		3	91401-KVT-941	LABEL CAUTION.....	1	1	1	1

PART NO. INDEX - SPLENDOR PRO

PART NO.	BLOCK NO.	PART NO.	BLOCK NO.	PART NO.	BLOCK NO.	PART NO.	BLOCK NO.	PART NO.	BLOCK NO.
11000		14000		16000		17000		23000	
11100-KWH-960	E-8	14311-035-000	E-9	16148-KPL-901	E-13	17512-KCC-900	F-23	23217-GF6-000L	E-6
11191-GW8-681	E-8	14321-GB6-900	E-4	16155-KRS-861	E-13	17512-KWH-970	F-13	23221-GF6-000	E-10
11200-KWH-960	E-8	14401-178-000	E-4	16163-GFP-901	E-13	17521-KWH-970	F-13	23421-GB4-770	E-10
11200-KWH-970	E-8	14430-KST-940	E-3	16165-KWA-931	E-13	17525-KCC-900	F-13	23422-GB4-770	E-10
11321-KWA-940	E-7	14451-KST-940	E-3	16199-KWA-931	E-13	17611-KCC-900	F-13	23431-GN5-910	E-10
11321-KWA-940	E-7B	14500-035-020	E-4	16201-KWB-920	E-1	17613-KCC-900	F-13	23441-GB4-770	E-10
11330-AAD-H00	E-5	14502-086-000	E-4	16211-459-750	E-1	17622-GB7-900	F-25	23451-GK4-761	E-10
11341-AAD-H00	E-7	14531-035-000	E-4	16236-045-010	E-8	17681-KWH-970	F-13	23461-GK4-760	E-10
11341-AAD-H10	E-7A	14541-GB4-681	E-4	16950-KWH-970	F-13	17910-KWH-970	F-3	23471-GN5-910	E-10
11360-KWH-961	E-7	14550-GBO-910	E-4	16952-KWH-970	F-13			23481-HF7-000	E-10
11360-KWH-961	E-7A	14566-086-030	E-4	16958-397-770	F-13	18000		23801-178-000	E-10
11394-KW8-681	E-5	14610-086-000R	E-4			18291-KTC-900	F-16	23802-040-000	E-10
11395-GBJ-731	E-7A	14615-035-010	E-4	17000		18293-KPK-900	F-16		
		14670-035-030L	E-4	17110-KCC-870	E-1	18345-MBT-610	F-16	24000	
		14675-178-000	E-4	17212-KTC-900	F-15	18350-AAD-H00	F-16	24211-GF6-000R	E-12
		14711-GN5-910	E-3	17213-KWA-940	F-15	18355-KWH-970	F-16	24261-121-742	E-12
		14721-GF6-010	E-3	17214-KWH-840	F-15	18600-KWA-930	F-25	24263-028-000	E-12
		14751-GBG-900	E-3	17214-KWH-970	F-15	18600-KWA-940	F-25	24301-KWA-930	E-12
		14761-GBG-900	E-3	17214-KWH-970	F-24	18640-KCC-940	E-2	24411-198-900	E-12
		14771-GB4-680	E-3	17214-KWH-970	F-24	18645-MT4-730	E-2	24421-200-000	E-12
		14775-MA6-000	E-3	17218-KTC-900	F-15	18651-KCC-940	F-25	24425-198-900	E-12
		14781-MA6-000	E-3	17219-KTC-900	F-15	18651-KWA-940	F-25	24430-198-900	E-12
				17220-KWA-940	F-15	18652-KCC-940	F-25	24435-GB4-770	E-12
		15000		17224-KWH-970	F-15	18652-KWA-940	F-25	24610-KST-940	E-12
		15100-KCC-900	E-8	17225-KWA-840	F-15	18653-198-D00	F-25	24639-035-000L	E-12
		15119-178-000	E-8	17234-KCC-940	F-15	18655-KWA-940	E-1	24641-041-000	E-12
		15384-178-000	E-8	17251-KWA-940	F-15	19000		24651-035-000L	E-12
		15421-035-010	E-8	17253-KTC-900	F-15	19509-198-770	F-25	24652-035-000	E-12
		15431-198-000	E-6	17316-611-000	E-8	22000		24701-KWA-940	F-17
		15439-198-691	E-6	17361-KWA-940	F-15	22110-KST-940	E-6		
		15441-198-000	E-6	17369-198-770	F-25	22121-198-900	E-6	26000	
		15650-AAC-H00	E-5	17371-KWH-970	E-8	22201-GF6-000	E-6	26131-149-300	F-1V
		15661-198-000	E-6	17500-AAD-H70ZA	F-13	22311-107-000	E-6	28000	
				17500-AAD-H70ZB	F-13	22350-115-020	E-6	28101-KWA-940	E-7B
		16000		17500-AAD-H70ZC	F-13	22361-KST-940	E-6	28102-KWA-940	E-7B
		16010-KWA-931	E-13	17500-AAD-H70ZD	F-13	22401-GF6-000	E-6	28103-GB4-700	E-7B
		16012-KWA-931	E-13	17500-AAD-H70ZE	F-13	22810-198-000	E-5	28110-AAD-H40	E-7B
		16013-KRB-901	E-13	17500-AAD-H70ZF	F-13	22815-166-000	E-5	28117-KFL-850	E-7B
		16014-KTR-A01	E-13	17500-AAD-H70ZG	F-13	22847-KCC-900	E-6	28120-KWA-942	E-7B
		16015-KVW-921	E-13	17500-AAD-H70ZH	F-13	22870-KWH-970	F-3	28211-GF6-000	E-11
		16016-KPH-651	E-13	17509-398-960	F-21	22871-116-670	F-3	28221-198-010	E-11
		16016-KPH-651	E-13	17511-KWH-970ZA	F-13	23000		28251-GF6-000	E-11
		16022-KWA-931	E-13	17511-KWH-970ZC	F-13	23112-198-010	E-6	28253-397-000	E-11
		16028-KST-941	E-13	17511-KWH-970ZD	F-13	23121-KST-901	E-6	28254-198-000	E-11
		16037-KPH-901	E-13	17511-KWH-970ZE	F-13	23211-GF6-000	E-10	28256-198-000	E-11
		16060-KWA-933	E-13	17511-KWH-970ZF	F-13	23216-GF6-000	E-6	28261-198-000	E-11
		16075-KTC-901	E-13	17511-KWH-970ZG	F-13			28262-198-000	E-11
		16076-KPL-901	E-13	17511-KWH-970ZH	F-13			28293-KAG-900	F-17
		16100-KWH-961	E-13	17512-KCC-900	F-13				
		16118-KTR-A01	E-13						



PART NO. INDEX - SPLENDOR PRO

PART NO.	BLOCK NO.	PART NO.	BLOCK NO.	PART NO.	BLOCK NO.	PART NO.	BLOCK NO.	PART NO.	BLOCK NO.
28000		33000		35000		42000		45000	
28302-KWA-940	F-17	33120-AAD-H00	F-1V	35357-KCC-900	F-18	42304-198-900	F-11	45133-KCC-900	F-8
2830A-KWH-760	F-17	33128-KCC-910	F-1V	35701-KWA-931	E-13	42313-198-900	F-10	45133-KCC-900	F-10
28321-427-770	F-17	33130-KWH-960	F-1V	35750-001-000	E-12	42601-AAE-H20	F-11	45134-250-000	F-8
28333-124-000	F-17	33136-426-830	F-1V	35753-035-010	E-12	42601-KTR-940	F-11	45134-250-000	F-10
30000		33153-KCC-830	F-1V	35755-001-000	E-12	42603-198-900	F-9	45141-KTC-900	F-8
30401-KWH-961	F-24	33402-KWH-960	F-22	37000		42603-198-900	F-11	45145-096-650	F-8
30410-KWH-961	F-24	33405-KWH-961	F-22	37100-AAD-H00	F-2V	42611-KST-940	F-11	45145-096-650	F-10
30500-AAF-H00	F-24	33407-KCC-900	F-22	37100-AAD-H63	F-2V	42615-198-900	F-11	45410-KCC-900	F-8
30700-KSP-B01	F-24	33408-KCC-900	F-22	37113-KWH-961	F-2V	42620-198-900	F-11	45435-GB2-720	F-8
31000		3340A-KWH-961	F-22	37210-AAD-H00	F-2V	42620-GB6-920	F-11	45450-KCC-710	F-3
31100-KWH-961	E-7A	33415-KWH-961	F-22	37215-MB6-830	F-2V	42653-001-000	F-11	45451-KCC-900	F-6
31100-KWH-971	E-7	33452-KWH-960	F-22	37215-MB6-830	F-2V	42711-KTR-901	F-11	46000	
31110-KWH-961	E-7	33455-KWH-961	F-22	37230-KWH-961	F-13	42712-KCS-920	F-9	46500-KWA-910	F-18
31110-KWH-961	E-7A	3345A-KWH-961	F-22	37243-323-000	F-17	42712-KCS-920	F-11	46514-KCC-900	F-18
31120-KWH-961	E-7	33465-KWH-961	F-22	37300-AAD-H00	F-2V	42713-KFN-850	F-9	46515-KB9-000	F-18
31120-KWH-961	E-7A	33490-KCC-900	F-22	37610-KWH-961	F-2V	42713-KFN-850	F-11	50000	
31201-KG8-004	E-7C	3360A-KWH-961	F-22	37612-KCC-900	F-2V	43000		50100-KWH-960	F-25
31202-GB2-700L	E-7C	33615-KWH-961	F-22	37614-KCC-900	F-2V	43100-153-600	F-10	50100-KWH-970	F-25
31204-KG8-004	E-7C	33619-459-840A	F-16	37619-KWH-961	F-2V	43100-153-6012	F-10	50160-KCC-900	F-17
31205-KWA-941	E-7C	3365A-KWH-961	F-22	37800-KWH-962	F-13	43125-KRP-981	F-8	50186-KCC-870	F-21
31208-KWA-941	E-7C	33665-KWH-961	F-22	38000		43125-KRP-981	F-10	50211-KCC-900	F-25
31210-KWA-941	E-7C	33701-KST-930	F-23	38110-KTR-A01	F-5	43125-KTN-701	F-8	50250-KCC-870	F-25
31211-KWA-941	E-7C	33702-KCC-830	F-23	38117-KFE-701	F-5	43141-KST-920	F-10	50301-KTR-900	F-5
31213-GB4-701L	E-7C	33704-KST-930	F-23	38210-KWA-831	F-24	43410-KST-940	F-10	50383-KTC-900	F-15
31500-KVT-801	F-24	33709-KCC-830	F-23	38210-KWA-831	F-24	43431-198-900	F-19	50500-KWH-760	F-18
31500-KWS-801	F-24	33714-KL3-620	F-5	38301-KWH-961	F-24	43434-286-000	F-10	50505-KCC-900	F-16
31600-KWF-841	F-24	33741-KST-920	F-21	38306-GE7-000	F-24	43451-KCC-600	F-18	50512-KTC-900	F-18
31700-124-000	F-24	34000		38501-KWH-971	F-24	44000		50530-KCC-900	F-17
32000		34901-KSP-910	F-1V	38502-KSP-910	F-24	44301-KTR-700	F-9	50603-KB4-000	F-17
32100-KWH-960	F-24	34906-KST-920	F-23	38506-KWA-840	F-24	44311-KRC-900	F-9	50614-413-000	F-17
32100-KWH-970	F-24	34908-GA7-700	F-1V	38506-KWA-940	F-24	44601-AAE-H20	F-9	50618-KCC-000	F-17
32108-344-820	F-24	34910-KWA-930	F-2V	40000		44601-KTR-940	F-9	50619-425-010	F-17
32161-404-000	F-3	34920-KWA-930	F-2V	40510-KWH-970	F-19	44620-198-900	F-9	50619-KCC-000	F-17
32410-KVH-871	E-7C	34930-KWA-930	F-22	40520-KST-940Z	F-19	44620-400-000	F-9	50661-425-670	F-17
32712-ZA0-000	F-25	35000		40530-KST-941	F-19	44701-AAC-H00	F-9	50701-KWA-830	F-17
32961-KST-940	E-7	35010-AAD-H00	F-2V	40531-KTE-912	F-19	44701-AAC-H50	F-11	50702-KST-940	F-17
32961-KST-940	E-7A	35100-AAD-H00	F-2V	40543-198-900	F-10	44711-KFN-850R	F-9	50710-461-770	F-17
32981-GB4-780	E-7	35121-KVH-850	F-2V	40544-198-900	F-11	44805-KTC-900	F-8	50712-438-730	F-17
32981-GB4-780	E-7A	35122-KVH-850	F-2V	40545-001-000	F-19	44806-KST-900	F-8	50713-438-730	F-17
33000		35150-KWA-841	F-3	41000		44809-170-000	F-8	50715-KCC-900	F-17
33100-S2K-003	F-1V	35200-KWH-960	F-3	41201-KVH-760	F-11	44810-KTC-900	F-8	50718-KCC-900	F-17
33107-300-000	F-1V	35200-KWH-970	F-3	41241-KST-941	F-11	44830-KWA-910	F-2V	50720-AAD-H00	F-12
3310B-AAD-H00	F-1V	35330-413-000	F-3	42000		44831-KTC-900	F-2V	50803-KWH-760	F-28
33112-KWH-960	F-1V	35340-KST-950	F-3	42301-KST-940	F-11	45000		51000	
33117-KB7-910	F-1V	35350-KWA-940	F-18	42303-KST-940	F-11	45010-KTC-900	F-8	51103-KWH-970	F-29
		35350-KWH-960	F-18			45010-KTR-700	F-8	51104-KST-940	F-29

PART NO. INDEX - SPLENDOR PRO

PART NO.	BLOCK NO.	PART NO.	BLOCK NO.	PART NO.	BLOCK NO.	PART NO.	BLOCK NO.	PART NO.	BLOCK NO.
51000		53000		77000		83000		86000	
51106-KCC-900	F-29	53214-200-000	F-5	77300-AAD-H70ZD	F-12	83515-KWH-970	F-25	86772-AAD-H70ZC	F-27
51400-KST-A11	F-7	53215-KTR-900	F-5	77300-AAD-H70ZE	F-12	83520-KTC-900	F-25	86772-AAD-H70ZD	F-27
51401-KST-941	F-7	53221-KTR-900	F-5	77300-AAD-H70ZF	F-12	83550-KWH-961	F-14	86772-AAD-H70ZE	F-27
51403-447-730	F-7	53222-KTR-900	F-5	77300-AAD-H70ZG	F-12	83550-KWH-961	F-25	86772-AAD-H70ZF	F-27
51403-KCC-900	F-7	53230-KWH-960	F-4	77300-AAD-H70ZH	F-12	83551-300-000	F-12	86772-AAD-H70ZG	F-27
51410-KWA-941	F-7			77400-AAD-H70ZA	F-12	83551-300-000	F-13	86772-AAD-H70ZH	F-27
51412-KAG-900	F-7	61000		77400-AAD-H70ZB	F-12	83600-AAD-H70ZA	F-14	86773-KWH-970ZA	F-27
51412-KWA-941	F-7	61100-KST-940ZA	F-6	77400-AAD-H70ZC	F-12	83600-AAD-H70ZB	F-14	86773-KWH-970ZB	F-27
51420-KST-A11	F-7	61100-KST-940ZB	F-6	77400-AAD-H70ZD	F-12	83600-AAD-H70ZC	F-14	86831-AAD-H70ZA	F-27
51425-KST-901	F-7	61100-KST-940ZD	F-6	77400-AAD-H70ZE	F-12	83600-AAD-H70ZD	F-14	86831-AAD-H70ZB	F-27
51432-KST-901	F-7	61100-KWH-970ZC	F-6	77400-AAD-H70ZF	F-12	83600-AAD-H70ZE	F-14	86831-AAD-H70ZC	F-27
51437-KVN-901	F-7	61100-KWH-970ZE	F-6	77400-AAD-H70ZG	F-12	83600-AAD-H70ZF	F-14	86831-AAD-H70ZD	F-27
51440-KTR-901	F-7	61100-KWH-970ZF	F-6	77400-AAD-H70ZH	F-12	83600-AAD-H70ZG	F-14	86831-AAD-H70ZE	F-27
51500-KST-A11	F-7	61100-KWH-970ZG	F-6			83600-AAD-H70ZH	F-14	86831-AAD-H70ZF	F-27
51520-KST-A11	F-7	61100-KWH-970ZH	F-6	80000				86831-AAD-H70ZG	F-27
52000		61102-KST-940	F-6	80100-KWH-970	F-21	84000		86831-AAD-H70ZH	F-27
52101-KST-940	F-19	61103-357-000	F-23	80101-443-000	F-1V	84103-KCC-900	F-12	86832-AAD-H70ZA	F-27
52110-AAJ-H40	F-19	61104-KM7-910	F-23	80101-443-000	F-2V	84701-KCC-860	F-21	86832-AAD-H70ZB	F-27
52147-KTC-900	F-19	61107-KK6-000	F-23	80102-KCC-900	F-23	84701-P26-D00A	F-21	86832-AAD-H70ZC	F-27
52170-AAJ-H40	F-19	61107-KK6-000	F-25	80123-KCC-870	F-21	84702-KCC-900	F-12	86832-AAD-H70ZD	F-27
52400-KWH-961	F-20	61311-KWH-970	F-1V	80150-KCC-900	F-23			86832-AAD-H70ZE	F-27
52410-KCC-871	F-20	61312-KCC-900	F-1V			86000		86832-AAD-H70ZF	F-27
52486-KAG-900	F-20	61317-KCC-900	F-2V			86171-AAD-H70ZA	F-27	86832-AAD-H70ZG	F-27
52486-KTN-701	F-20			81000		86171-AAD-H70ZB	F-27	86832-AAD-H70ZH	F-27
52489-399-600	F-20			81200-KWH-970	F-12	86171-AAD-H70ZC	F-27	86833-AAD-H70ZA	F-27
52495-098-000	F-20					86171-AAD-H70ZD	F-27	86833-AAD-H70ZB	F-27
		75581-673-000	F-13			86171-AAD-H70ZE	F-27	86833-AAD-H70ZC	F-27
		75581-673-000	F-14			86171-AAD-H70ZF	F-27	86833-AAD-H70ZD	F-27
		75581-673-000	F-25			86171-AAD-H70ZG	F-27	86833-AAD-H70ZE	F-27
53000						86171-AAD-H70ZH	F-27	86833-AAD-H70ZF	F-27
53100-KWH-970	F-4					86172-AAD-H70ZA	F-27	86833-AAD-H70ZG	F-27
53131-AAF-H00	F-4					86172-AAD-H70ZB	F-27	86833-AAD-H70ZH	F-27
53132-124-000	F-4					86172-AAD-H70ZC	F-27	86834-AAD-H70ZA	F-27
53133-198-900	F-4					86172-AAD-H70ZD	F-27	86834-AAD-H70ZB	F-27
53134-028-000	F-4					86172-AAD-H70ZE	F-27	86834-AAD-H70ZC	F-27
53135-198-900	F-4					86172-AAD-H70ZF	F-27	86834-AAD-H70ZD	F-27
53136-198-900	F-4					86172-AAD-H70ZG	F-27	86834-AAD-H70ZE	F-27
53140-KCC-900	F-3					86172-AAD-H70ZH	F-27	86834-AAD-H70ZF	F-27
53166-KY0-750	F-3					86511-KVH-780	F-27	86834-AAD-H70ZG	F-27
53167-GE4-000	F-3					86771-AAD-H70ZA	F-27	86834-AAD-H70ZH	F-27
53168-166-000	F-3					86771-AAD-H70ZB	F-27	86834-AAD-H70ZA	F-27
53171-198-900	F-3					86771-AAD-H70ZC	F-27	86836-AAD-H70ZA	F-27
53171-KCC-900	F-3					86771-AAD-H70ZD	F-27	86836-AAD-H70ZB	F-27
53172-KTC-920	F-3					86771-AAD-H70ZE	F-27		
53175-KVH-850	F-3					86771-AAD-H70ZF	F-27	87000	
53178-KVH-850	F-3					86771-AAD-H70ZG	F-27	87117-KWH-970	F-14
53179-KTC-900	F-3					86771-AAD-H70ZH	F-27	87501-AAE-H20	F-30
53200-KST-950	F-5					86772-AAD-H70ZA	F-27	87507-MZ8-W00	F-30
53211-268-010	F-5					86772-AAD-H70ZB	F-27		
53212-200-000	F-5								

PART NO. INDEX - SPLENDOR PRO

PART NO.	BLOCK NO.	PART NO.	BLOCK NO.	PART NO.	BLOCK NO.	PART NO.	BLOCK NO.	PART NO.	BLOCK NO.
88000		90000		90000		91000		94000	
88110-AAC-H41ZA	F-3	90108-223-000	F-17	90461-357-000	E-4	91303-GF6-000	E-8	93913-24320	F-12
88110-AAC-H41ZB	F-3	90111-187-000	F-15	90461-459-000	E-10	91304-GB1-900	E-1	94001-06000-0S	F-10
88110-AAC-H41ZC	F-3	90111-187-000	F-21	90461-GB4-770	E-10	91305-028-150	E-2	94001-06000-0S	F-11
88110-AAC-H41ZD	F-3	90114-310-000	F-3	90461-GF6-000	E-6	91305-MC7-000	F-13	94001-06000-OS	F-3
88110-AAC-H41ZE	F-3	90116-KAG-900	F-7	90481-035-000	E-4	91307-035-000	E-5	94001-06070-0S	F-2V
88110-AAC-H41ZF	F-3	90116-KCC-900	F-25	90501-KC2-750	F-25	91308-GB4-701L	E-7C	94001-08000-0S	F-10
88110-AAC-H41ZG	F-3	90117-KCC-900	F-25	90501-KCC-870	F-6	91309-GB2-701L	E-7C	94001-08000-0S	F-19
88110-AAC-H41ZH	F-3	90118-383-000	F-19	90502-198-900	F-18	91312-107-000	E-12	94001-10000-0S	F-20
88114-198-D10	F-3	90123-KRM-860	F-7	90503-KTR-900	F-4	91317-171-000	E-7	94021-06000-0S	F-25
88120-AAC-H41ZA	F-3	90123-KST-941	F-7	90505-425-000	F-10	91317-171-000	E-7B	94021-10000-0S	F-20
88120-AAC-H41ZB	F-3	90133-331-770	F-19	90521-292-000	F-7	91352-GAZ-930	F-2V	94030-08000	F-25
88120-AAC-H41ZC	F-3	90150-GN5-901	F-1V	90544-439-930	F-7	91356-KAG-900	F-7	94030-10000	F-17
88120-AAC-H41ZD	F-3	90183-KTC-900	F-19	90551-178-000	F-20	91356-KGH-901	E-7	94050-05000	F-17
88120-AAC-H41ZE	F-3	90201-GF6-000R	E-1	90563-355-000	F-12	91356-KGH-901	E-7A	94050-06000	F-6
88120-AAC-H41ZF	F-3	90201-MW3-620	F-3	90601-001-000	E-10	91509-GE2-760	F-25	94050-06000	F-8
88120-AAC-H41ZG	F-3	90206-001-000	E-3	90601-459-000	E-10			94050-06000	F-13
88120-AAC-H41ZH	F-3	90231-087-010	E-6	90601-459-000	E-11	92000		94050-06000	F-22
		90231-198-000	E-6	90601-GF5-730	F-7	92000-05022-0H	F-23	94050-08000	F-16
89000		90302-KBP-900	F-11	90701-GF6-000	E-2	92000-06008-0H	E-10	94050-10000	E-7
89102-538-000	F-26	90302-KST-942	F-10	90702-GB6-910	E-4	92000-06012-0A	F-19	94050-10000	E-7A
89103-538-000	F-26	90304-438-000	F-16	90702-GB6-910	E-5	92000-06016-0A	F-17	94101-04800	F-1V
89215-AAC-000	F-26	90304-KSP-900	F-4	90702-GB6-910	E-7	92000-06016-0A	F-21	94101-05000	F-15
89216-AAD-H00	F-26	90304-KTE-911	F-4	90702-GB6-910	E-7A	92000-06020-0H	F-17	94101-06000	F-11
		90304-KTE-911	F-17	90703-HC4-000	E-8	92000-06025-0A	F-3	94101-06000	F-17
90000		90306-KST-942	F-9	90741-KFB-000	E-9	92000-08012-0A	F-1V	94101-06000	F-19
90003-KCC-840	F-3	90306-KST-942	F-10	90753-029-000	F-11	92101-06032-0A	F-17	94101-06000	F-21
90012-333-000	E-3	90306-KST-942	F-11	90755-229-000	F-9	92800-12000-00	E-8	94101-08000	F-1V
90022-GFP-900	E-12	90306-KTE-911	F-19	90801-035-000	E-12	92811-10000	F-10	94101-08000	F-5
90023-KL8-730	F-4	90307-001-000	F-11	90810-KCC-910	F-12			94101-08000	F-17
90031-GF6-000R	E-8	90311-MT3-000	F-15	91000		93000		94101-08000	F-19
90032-GF6-000R	E-8	90313-172-000	F-14	91101-AAC-H40	E-9	93401-06010-00	F-19	94101-08000	F-19
90033-041-020	E-2	90320-GC3-000	F-21	91102-AAC-H40	E-9	93500-04040-OH	F-1V	94101-12800	F-20
90050-KFL-850	E-6	90324-KCC-900	F-13	91103-AAC-H40	E-9	93500-05006-OH	F-13	94103-06700	F-2V
90071-171-010	E-12	90325-KCC-900	F-13	91201-GBG-900	E-7B	93500-05016-1H	F-15	94111-08000	F-25
90081-035-000	E-4	90380-MB2-000	F-22	91202-302-010	E-5	93500-05022-1G	F-3	94111-10000	F-19
90081-GFP-900	E-2	90407-259-000	E-8	91202-KTL-741	E-7	93600-05012-1H	E-6	94201-16150	F-17
90083-KVH-900	E-4	90410-HC4-000	E-7	91203-KTL-741	E-7	93600-06016-0A	E-7B	94201-20150	F-10
90083-KVH-900	E-7	90410-HC4-000	E-7A	91203-GB5-760	E-10	93600-06016-0A	E-7	94201-20150	F-18
90083-KVH-900	E-7A	90432-086-000	E-6	91204-GBG-850	E-7B	93700-04012-1G	F-22	94201-20150	F-19
90084-KWH-960	E-7	90441-035-000	E-4	91205-350-000	E-6	93892-04006-08L	E-7C	94201-30250	F-18
90084-KWH-960	E-7A	90442-GF6-000	E-1	91208-KB4-670	E-12	93892-04010-10	E-13	94510-12000L	E-7C
90085-KWA-940	E-7B	90443-GF6-000	E-1	91251-GK4-000	F-8	93892-04014-08	E-13	94510-16000	E-11
90087-KWH-960	E-7	90451-198-000	E-10	91255-KWA-941	F-7	93892-05030-08L	E-7C	95000	
90087-KWH-960	E-7A	90451-GF6-000	E-10	91301-035-000	E-7	93901-24510	F-23	95002-02070	F-25
90101-KCC-940	F-25	90452-115-000	E-11	91301-035-000	E-7B	93901-34210	F-1V	95002-02080	F-13
90104-KCC-870	F-6	90452-GB4-770	E-10	91302-KEV-900	E-1	93901-34420	F-22	95002-02089	E-13
90107-428-000	F-12	90454-107-000	E-11	91303-377-000	E-7	93903-25120	F-15	95002-02100	E-8
90107-KAN-900	F-16	90461-035-000	E-10	91303-377-000	E-7A	93903-25220	F-25	95002-02130	F-15
90108-223-000	F-2V	90461-357-000	E-1	91303-719-000	E-5	93913-24320	F-2V	95002-02659	E-13

PART NO. INDEX - SPLENDOR PRO

PART NO.	BLOCK NO.	PART NO.	BLOCK NO.	PART NO.	BLOCK NO.	PART NO.	BLOCK NO.
95000		96000		98000			
95002-80000	E-8	96001-06016-00	E-8	98200-31500	F-24		
95005-35170-20	F-25	96001-06016-00	F-23	99000			
95005-35260-50	E-13	96001-06016-07	F-1V	99007-45000	F-26		
95011-51000	F-17	96001-06018-00	E-4	99101-KWA-1050	E-13		
95014-71702	F-18	96001-06020-00	E-1	99103-KTC-0350	E-13		
95014-72302	F-17	96001-06020-00	E-6				
95014-73100	F-18	96001-06020-00	E-7				
95015-32001	F-8	96001-06020-00	E-7A				
95015-32001	F-18	96001-06020-00	F-24				
95015-42000	F-8	96001-06022-00	E-1				
95015-42000	F-18	96001-06025-00	E-1				
95015-53000	F-18	96001-06025-00	E-8				
95015-81000	F-17	96001-06028-00	E-7				
95018-46320	F-15	96001-06028-00	E-7A				
95701-06010-08	F-25	96001-06032-00	E-7				
95701-06012-00	F-21	96001-06032-00	E-7A				
95701-06012-08	F-6	96001-06040-00	E-5				
95701-06012-08	F-15	96001-06045-00	E-7C				
95701-06012-08	F-24	96001-06050-00	E-7A				
95701-06014-18	F-24	96001-06050-00	E-8				
95701-06016-07	F-25	96001-06060-00	E-7				
95701-06016-08	F-15	96001-06060-00	E-8				
95701-06018-08	F-23	96001-06065-00	E-5				
95701-06020-00	E-11	96001-06065-00	E-8				
95701-06020-00	F-6	96001-06070-00	E-7				
95701-06020-07	F-5	96001-06070-00	E-7A				
95701-06020-08	F-21	96001-06080-00	E-5				
95701-06025-18	F-12	96100-60010-00	E-6				
95701-06032-00	F-8	96100-60010-00	E-10				
95701-06035-00	F-10	96100-62010-00	E-10				
95701-06110-00	E-1	96100-62030-00	E-10				
95701-08016-00	F-12	96120-60010-10L	E-7C				
95701-08016-00	F-16	96140-63010-10	F-9				
95701-08016-00	F-25	96140-63010-10	F-11				
95701-08016-00	F-28	96150-62030-10	F-11				
95701-08016-00	F-29	96211-08000	F-5				
95701-08016-07	F-17	96211-08000	F-17				
95701-08028-00	F-29	96220-30085	E-12				
95701-08035-00	F-29	96700-08020-00	F-2V				
95701-08035-08	F-13	97000					
95701-08040-00	F-5	97252-51162-10	F-9				
95701-10045-07	F-25	97338-51179-10	F-11				
96000		97603-51162-10	F-9				
96001-06010-00	E-7B	97604-51178-10	F-11				
96001-06012-00	E-12	98000					
96001-06016-00	E-2	98056-57718-00	E-1				
96001-06016-00	E-7	98200-31000	F-24				
96001-06016-00	E-7A						

AMENDMENTS RECORD

S.No.	Page No.	Old Part No.	Revised Part No.	Date	Signature	Remarks